



# DRILLING ENGINEERING

PROBLEMS AND SOLUTIONS

A FIELD GUIDE FOR ENGINEERS AND STUDENTS

M.E. HOSSAIN  
M.R. ISLAM

 Scrivener  
Publishing

WILEY

# Drilling Engineering Problems and Solutions

**Scrivener Publishing**

100 Cummings Center, Suite 541J  
Beverly, MA 01915-6106

*Publishers at Scrivener*

Martin Scrivener ([martin@scrivenerpublishing.com](mailto:martin@scrivenerpublishing.com))  
Phillip Carmical ([pcarmical@scrivenerpublishing.com](mailto:pcarmical@scrivenerpublishing.com))

**Drilling Engineering  
Problems and Solutions**  
**A Field Guide for Engineers  
and Students**

**M. E. Hossain and M. R. Islam**



**WILEY**

This edition first published 2018 by John Wiley & Sons, Inc., 111 River Street, Hoboken, NJ 07030, USA and Scrivener Publishing LLC, 100 Cummings Center, Suite 541J, Beverly, MA 01915, USA

© 2018 Scrivener Publishing LLC

For more information about Scrivener publications please visit [www.scrivenerpublishing.com](http://www.scrivenerpublishing.com).

All rights reserved. No part of this publication may be reproduced, stored in a retrieval system, or transmitted, in any form or by any means, electronic, mechanical, photocopying, recording, or otherwise, except as permitted by law. Advice on how to obtain permission to reuse material from this title is available at <http://www.wiley.com/go/permissions>.

#### **Wiley Global Headquarters**

111 River Street, Hoboken, NJ 07030, USA

For details of our global editorial offices, customer services, and more information about Wiley products visit us at [www.wiley.com](http://www.wiley.com).

#### **Limit of Liability/Disclaimer of Warranty**

While the publisher and authors have used their best efforts in preparing this work, they make no representations or warranties with respect to the accuracy or completeness of the contents of this work and specifically disclaim all warranties, including without limitation any implied warranties of merchantability or fitness for a particular purpose. No warranty may be created or extended by sales representatives, written sales materials, or promotional statements for this work. The fact that an organization, website, or product is referred to in this work as a citation and/or potential source of further information does not mean that the publisher and authors endorse the information or services the organization, website, or product may provide or recommendations it may make. This work is sold with the understanding that the publisher is not engaged in rendering professional services. The advice and strategies contained herein may not be suitable for your situation. You should consult with a specialist where appropriate. Neither the publisher nor authors shall be liable for any loss of profit or any other commercial damages, including but not limited to special, incidental, consequential, or other damages. Further, readers should be aware that websites listed in this work may have changed or disappeared between when this work was written and when it is read.

#### ***Library of Congress Cataloging-in-Publication Data***

ISBN 978-1-118-99834-2

Cover image: 71175853 © Pichit Boonhuad | Dreamstime.com

Cover design by Kris Hackerott

Set in size of 11pt and Minion Pro by Exeter Premedia Services Private Ltd., Chennai, India

Printed in the USA

10 9 8 7 6 5 4 3 2 1

*To first author's mother, the late Azizun Nesa and uncle the late  
Mohammad Ismail*

# Contents

---

<b>Foreword</b>	<b>xvii</b>
<b>Acknowledgements</b>	<b>xix</b>
<b>1 Introduction</b>	<b>1</b>
1.0 Introduction of the Book	1
1.1 Introduction of Drilling Engineering	2
1.2 Importance of Drilling Engineering	2
1.3 Application of Drilling Engineering	3
1.4 Drilling Problems, Causes, and Solutions	3
1.5 Drilling Operations and its Problems	4
1.5.1 Common Drilling Problems	5
1.6 Sustainable Solutions for Drilling Problems	6
1.7 Summary	8
References	8
<b>2 Problems Associated with Drilling Operations</b>	<b>11</b>
2.0 Introduction	11
2.1 Problems Related to Drilling Methods and Solutions	12
2.1.1 Sour Gas Bearing Zones	12
2.1.1.1 How to Tackle H <sub>2</sub> S	12
2.1.2 Shallow Gas-Bearing Zones	17
2.1.2.1 Prediction of Shallow Gas Zone	18
2.1.2.2 Identification of Shallow Gas Pockets	19
2.1.2.3 Case Study	20
2.1.3 General Equipment, Communication, and Personnel Related Problems	24
2.1.3.1 Equipment	24
2.1.3.2 Communication	28
2.1.3.3 Personnel	30
2.1.4 Stacked Tools	31
2.1.4.1 Objects Dropped into the Well	32
2.1.4.2 Fishing Operations	34

2.1.4.3	Junk Retrieve Operations	45
2.1.4.4	Twist-off	46
2.1.5	Difficult-to-drill Rocks	48
2.1.6	Resistant Beds Encountered	48
2.1.7	Slow Drilling	49
2.1.7.1	Factors Affecting Rate of Penetration	50
2.1.8	Marginal Aquifer Encountered	62
2.1.9	Well Stops Producing Water	62
2.1.10	Drilling Complex Formations	63
2.1.11	Complex Fluid Systems	63
2.1.12	Bit Balling	64
2.1.13	Formation Cave-in	66
2.1.14	Bridging in Wells	67
2.1.14.1	Causes of Bridging in Wells	69
2.1.14.2	Warning Signs of Cutting Setting in Vertical Well	70
2.1.14.3	Remedial Actions of Bridging in Wells	70
2.1.14.4	Preventive Actions	71
2.1.14.5	Volume of Solid Model	71
2.2	Summary	73
References		73
<b>3</b>	<b>Problems Related to the Mud System</b>	<b>77</b>
3.0	Introduction	77
3.1	Drilling Fluids and its Problems with Solutions	78
3.1.1	Lost Circulation	79
3.1.1.1	Mechanics of Lost Circulation	86
3.1.1.2	Preventive Measures	88
3.1.1.3	Mud Loss Calculation	90
3.1.1.4	Case Studies	92
3.1.2	Loss of Rig Time	95
3.1.3	Abandonment of Expensive Wells	96
3.1.4	Minimized Production	97
3.1.5	Mud Contamination	97
3.1.5.1	Sources and Remediation of the Contamination	99
3.1.6	Formation Damage	104
3.1.6.1	Prevention of Formation Damage	113
3.1.6.2	Quantifying Formation Damage	116
3.1.7	Annular Hole Cleaning	118
3.1.7.1	New Hole Cleaning Devices	120



3.1.8	Mud Cake Formation	122
3.1.8.1	Filtration Tests	123
3.1.8.2	Mud Cake Removal Using Ultrasonic Wave Radiation	124
3.1.8.3	Wellbore Filter Cake Formation Model	125
3.1.9	Excessive Fluid Loss	126
3.1.10	Drilling Fluid Backflow	128
3.2	General Case Studies on Lost Circulation	128
3.2.1	Lessons Learned	130
3.3	Summary	130
	References	131
<b>4</b>	<b>Problem Related to Drilling Hydraulics</b>	<b>139</b>
4.0	Introduction	139
4.1	Drilling Hydraulics and its Problems and Solutions	141
4.1.1	Borehole Instability	147
4.1.1.1	Hole Enlargement	148
4.1.1.2	Hole Closure	150
4.1.1.3	Fracturing	150
4.1.1.4	Collapse	151
4.1.1.5	Prevention and Remediation	153
4.1.2	Proper Hole Trajectory Selection	154
4.1.3	Drill Bit Concerns	156
4.1.3.1	Bit Balling	156
4.1.4	Hydraulic Power Requirement	157
4.1.5	Vibration	160
4.2	Overall Recommendations	161
4.2.1	The Rig Infrastructure	161
4.2.2	Problems Related to Stuckpipe	162
4.2.3	Mechanical Pipe Sticking	163
4.2.4	Borehole Instability	164
4.2.4.1	Bottom Hole Pressure (mud density)	165
4.2.4.2	Well Inclination and Azimuth	165
4.2.4.3	Physical/chemical Fluid-rock Interaction	165
4.2.4.4	Drillstring Vibrations	166
4.2.4.5	Drilling Fluid Temperature	166
4.2.5	Lost Circulation	166
4.2.6	Hole Deviation	167
4.3	Summary	168
	References	168

<b>5</b>	<b>Well Control and BOP Problems</b>	<b>171</b>
5.0	Introduction	171
5.1	Well Control System	172
5.2	Problems with Well Control and BOP and their Solutions	174
5.2.1	Kicks	174
5.2.1.1	Warning Signals of Kicks	177
5.2.1.2	Control of Influx and Kill Mud	180
5.2.2	Blowout	197
5.3	Case Studies	199
5.3.1	Blowout in East Coast of India	199
5.3.1.1	Solutions	201
5.3.1.2	Causes of the Blowout	203
5.3.1.3	Lessons Learned and Recommendations	204
5.3.2	Deepwater Horizon Blowout	205
5.3.2.1	Solutions	207
5.3.2.2	Reasons Behind the Blowout	214
5.3.2.3	Lessons Learned and Recommendation	217
5.4	Summary	218
	References	219
<b>6</b>	<b>Drillstring and Bottomhole Assembly Problems</b>	<b>221</b>
6.0	Introduction	221
6.1	Problems Related to Drillstring and their Solutions	223
6.1.1	Stuck Pipe	223
6.1.1.1	Free Point – Stuck Point Location	224
6.1.1.2	The Most Common Causes of Stuck Pipe	227
6.1.1.3	Prevention of Stuck Pipe	229
6.1.1.4	Freeing Stuck Pipe	230
6.1.1.5	Measures to Reduce Stuck Pipe Costs	231
6.1.1.6	Some Examples of Field Practices	231
6.1.2	Drillpipe Failures	234
6.1.2.1	Twist-off	237
6.1.2.2	Parting and other Failures	240
6.1.2.3	Collapse and Burst	240
6.1.2.4	Tension Load	245
6.1.2.5	Fatigue	254
6.1.3	Problems Related to Catches	256
6.1.4	Fishing Operation	257
6.1.4.1	Stuck Pipe Fishing	257
6.1.4.2	Fishing for a “Twist-off”	257
6.1.5	Failures Caused by Downhole Friction Heating	258
6.1.5.1	Heat Check Cracking	259

6.1.5.2	Ductile and Brittle Fractures	260
6.1.5.3	Mathematical Models for Drillstring Failure	261
6.1.6	Vibration Induced Anomalies	264
6.1.6.1	Axial Vibrations	265
6.1.6.2	Torsional Vibrations	266
6.1.6.3	Lateral/transverse Vibrations	268
6.1.6.4	Fatigue	269
6.1.7	Drillstring Failures	270
6.1.8	Drill Bit Jamming	274
6.2	Case Studies	274
6.2.1	Vibration Control	274
6.2.1.1	Execution	276
6.2.1.2	Lessons Learned	278
6.2.2	Twist-off	279
6.3	Summary	280
	References	280
<b>7</b>	<b>Casing Problems</b>	<b>285</b>
7.0	Introduction	285
7.1	Problems Related to Casing and their Solutions	286
7.1.1	Casing Jams during Installation	287
7.1.2	Buckling	287
7.1.2.1	Buckling Criteria	288
7.1.2.2	General Guideline	292
7.1.3	Temperature Effect	292
7.1.4	Casing Leaks	294
7.1.5	Contaminated Soil/Water-Bearing Zones	297
7.1.6	Problem with Depth to Set Casing	299
7.1.6.1	Special Considerations of a Surface Casing	301
7.1.6.2	Practical Guideline	304
7.1.6.3	Influence of Casing Shoe Depth on Sustained Casing Pressure (SCP) during Production	306
7.2	Case Studies	311
7.2.1	Case Study – 1 (Casing Jamming)	313
7.2.1.1	Lessons Learned	314
7.2.2	Case Study – 2 (Casing Installation Problems)	314
7.2.3	Case Study – 3 (Casing Installation Problems in an Offshore Field)	316
7.2.3.1	Lessons Learned	316

7.2.4	Case Study – 4 (Leaky Casing)	318
7.2.4.1	Repair Alternatives	319
7.2.4.2	Setting Patches	320
7.2.4.3	Results and Lessons Learned	321
7.2.5	Case Study – 5 (Use of Gel for Water Leaks)	323
7.2.6	Case Study – 6 (Unusual Lithology)	325
7.2.6.1	Case 1: Leak below Production Packer	327
7.2.6.2	Case 2: Casing Shoe above Unsealed High Pressure Formation	329
7.2.6.3	Case 3: Casing Shoe set in Weak Formation	332
7.2.6.4	Case 4: Leak below Production Casing Shoe	334
7.2.6.5	Lessons Learned and Recommendations	336
7.2.7	Case Study – 7 (Surface Casing Setting)	340
7.2.7.1	Leak-off Tests	341
7.2.7.2	Reduction System	344
7.3	Summary	347
	References	347
<b>8</b>	<b>Cementing Problems</b>	<b>353</b>
8.0	Introduction	353
8.1	Problems Related to Cementing and their Solutions	354
8.1.1	Leaks due to Cement Failure	355
8.1.1.1	Preventive Methods	358
8.1.2	Key Seating	362
8.1.2.1	Prevention	363
8.1.2.2	Remediation	364
8.1.3	Cement Blocks	366
8.1.4	Problems Related to Mud/Cement Rheology	366
8.1.4.1	Contamination with Oil-based Mud	367
8.1.4.2	Problem Related to Eccentric Annulus	370
8.1.4.3	Flow Regime of Cement Displacement	372
8.1.4.4	Improper Mud Cake Removal during Cementing	374
8.1.4.5	Poor Mixing and/or Testing of Cement Slurry	375
8.1.5	Blowout Potentials	379
8.1.5.1	Overall Guidelines	381
8.2	Good Cementing Practices	382
8.2.1	Drilling Fluid	383
8.2.2	Hole Cleaning	384
8.2.3	Gel Strength	384

8.2.4	Spacers and Flushes	386
8.2.5	Slurry Design	388
8.2.6	Casing Rotation and Reciprocation	390
8.2.7	Centralizing Casing	391
8.2.8	Displacement Efficiency	392
8.2.9	Cement Quality	393
8.2.10	Special Considerations	394
8.3	Case Studies	394
8.3.1	Causes of Cement Job Failures	394
8.3.2	Casinghead Pressure Problems	398
8.3.3	Cases of Good Cement Jobs	401
8.3.3.1	Good Case I	402
8.3.3.2	Good Case II	403
8.3.3.3	Good Case III	403
8.3.3.4	Good Case IV	406
8.3.3.5	Good Case V	409
8.3.4	Cases of Failed Cement Jobs	413
8.3.4.1	Failed Cementing Case 01	416
8.3.4.2	Failed Case 02	417
8.3.4.3	Failed Case 03	428
8.3.4.4	Failed Case 04	429
8.4	Summary	440
	References	440
<b>9</b>	<b>Wellbore Instability Problems</b>	<b>443</b>
9.0	Introduction	443
9.1	Problems Related to Wellbore Instability and their Solutions	444
9.1.1	Causes of Wellbore Instability	445
9.1.1.1	Uncontrollable Factors	445
9.1.1.2	Controllable Factors	453
9.1.2	Indicators of Wellbore Instability	464
9.1.2.1	Diagnosis of Wellbore Instability	465
9.1.2.2	Preventative Measures	465
9.2	Case Studies	469
9.2.1	Chemical Effect Problems in Shaley Formation	469
9.2.1.1	Geological Considerations	470
9.2.1.2	Drilling Problems	470
9.2.1.3	Instability Mechanism	471
9.2.1.4	Instability Analysis	473
9.2.1.5	Shale Hydration	475

9.2.1.6	Dynamic Effects	479
9.2.1.7	Lessons Learned from Countermeasures	480
9.2.2	Minimizing Vibration for Improving Wellbore Stability	481
9.2.3	Mechanical Wellbore Stability Problems	483
9.2.3.1	Case Study for Well X-51 (Shale Problems)	483
9.2.3.2	Case Study for Well X-53 (Shale and Sand Problems)	486
9.2.3.3	Case Study for Well X-52 (Successful Case)	489
9.2.3.4	Lessons Learned	491
9.3	Summary	493
	References	494
<b>10</b>	<b>Directional and Horizontal Drilling Problems</b>	<b>497</b>
10.0	Introduction	497
10.1	Problems Related to Directional Drilling their Solutions	499
10.1.1	Accuracy of Borehole Trajectory	501
10.1.1.1	Guidelines and Emerging Technologies	507
10.1.2	Fishing with Coiled Tubing	508
10.1.3	Crookedness of Wells/Deflection of Wells	509
10.1.3.1	Causes of Crookedness	511
10.1.3.2	Outcomes of Crooked Borehole and Possible Remedies	515
10.1.4	Stuck Pipe Problems	517
10.1.5	Horizontal Drilling	520
10.1.5.1	Problems Associated with Horizontal Well Drilling	523
10.1.5.2	Unique Problems Related to Horizontal Well Drilling	526
10.2	Case Studies	527
10.2.1	Drilling of Multilateral and Horizontal Wells	527
10.2.1.1	Introduction	528
10.2.1.2	The Problem: Description and Solutions	528
10.2.1.3	Broader Picture	532
10.2.1.4	Lessons Learned	538
10.2.2	Directional Drilling Challenges in Deepwater Subsalt	539
10.2.2.1	Description of the Reservoir	540
10.2.2.2	Planning of Drilling	541
10.2.2.3	Drilling Operations	542

10.2.2.4	Planning the Sidetracks	543
10.2.2.5	Lessons Learned	545
10.3	Summary	545
	References	545
<b>11</b>	<b>Environmental Hazard and Problems during Drilling</b>	<b>549</b>
11.0	Introduction	549
11.1	Problems Related to Environment during Drilling	550
11.1.1	Environmental Degradation	551
11.1.1.1	Acoustics (Noise)	551
11.1.1.2	Air Quality	552
11.1.1.3	Contamination during Drilling	554
11.1.1.4	Cultural Resources	556
11.1.1.5	Ecological Resources	556
11.1.1.6	Environmental Justice	557
11.1.1.7	Hazardous Materials and Waste Management	558
11.1.1.8	Health and Safety	559
11.1.1.9	Land Use	560
11.1.1.10	Paleontological Resources	560
11.1.1.11	Socioeconomics	561
11.1.1.12	Soils and Geologic Resources	561
11.1.1.13	Transportation	562
11.1.1.14	Water Resources	562
11.1.2	Drill Cutting Management	563
11.1.2.1	Regulatory Aspects of Drill Cutting Disposal	567
11.1.3	Subsidence of Ground Surface	570
11.1.4	Deep Water Challenges	573
11.1.4.1	Narrow Operational Window	573
11.1.4.2	Marine Drilling Riser	573
11.1.4.3	Shallow Formation Hazards	574
11.1.4.4	Risk Analysis of Offshore Drilling	575
11.2	Case Studies	579
11.2.1	Effect of Drilling Fluid Discharge on Oceanic Organisms	579
11.2.1.1	Observations and Lessons Learned	582
11.2.2	Long-term Impact on Human Health	584
11.2.2.1	Lessons Learned	590
11.3	Summary	590
	References	590

<b>12 Summary and Conclusions</b>	<b>595</b>
12.1 Summary	595
12.2 Conclusions	596
12.2.1 Chapter 1: Introduction	596
12.2.2 Chapter 2: Problems Associated with Drilling Operations	597
12.2.3 Chapter 3: Problems Related to the Mud System	598
12.2.4 Chapter 4: Problem Related to Drilling Hydraulics	600
12.2.5 Chapter 5: Well Control and BOP Problems	601
12.2.6 Chapter 6: Drillstring and Bottomhole Assembly Problems	602
12.2.7 Chapter 7: Casing Problems	604
12.2.8 Chapter 8: Cementing Problems	606
12.2.9 Wellbore Instability Problems	608
12.2.10 Chapter 10: Directional and Horizontal Drilling Problems	611
12.2.11 Chapter 11: Environmental Hazard and Problems during Drilling	612
<b>Index</b>	<b>615</b>



## Foreword

---

With recent awareness of environmental sustainability, it has become clear that most of our technological advances are in fact a quick fix of problems that arose from practices that shouldn't have been commenced to begin with. At the risk of being labeled an anarchist, it is only proper to say, this fear has been shared by some of the most non-controversial engineers and scientists (Nobel Laureate Chemist, Robert Curl, for instance). In this era of technological advancement being later labelled as 'technological disaster', drilling technologies bring in a silver lining. The advancements made in drilling technologies have been phenomenal and marks one of the proudest moments of the petroleum industry. Unfortunately, whenever disasters strike, the blame game begins and everyone rushes to disavow modern technology. With the spectacular failure in Deep water horizon project in 2010, many questioned the validity of modern drilling advances, particularly in the areas of offshore drilling. Lost in that hysteria was the fact that research that fuelled the instant solutions sought during that fateful drilling operation was in fact flawed. After the dust settled, however, the tragic event established one fact: there has to be a Q&A type of problem solving book that addresses real-life drilling problems with well researched answers. This book is the first of its kind that addresses field problems and answers with solutions that can become a guide for avoiding such problems in future. The book doesn't compromise the relevance or scientific details in responding to hard hitting field problems. Rather than giving a technician's response or a quickfix, it gives a researcher's response with backing of field engineers with decades of experience. The book is a masterpiece that is helpful for practicing engineers as well as professors, who can better serve the discipline by introducing field problems that are solved with a combination of research and field experience.

S.T. Saleh, Geomech  
G.V. Chilingar, University of Southern California

## Acknowledgements

---

The first author would like to acknowledge the financial support provided by the Deanship of Scientific Research (DSR) at King Fahd University of Petroleum & Minerals (KFUPM) for funding this book-writing grant through project number IN141025. The support received from the department of Petroleum Engineering at KFUPM is also gratefully acknowledged. The author would like to thank Prof. Sidqi Ahmed Abu-Khamsin for his countless administrative support toward the accomplishment of the book project. The author acknowledges the support of his family members that provided him with full support during the book-writing project. The dedication of the author's wife gave him continuous support under all circumstances. During this long journey, the sacrifice of the children, Ijlal Hossain, Ryyan Hossain, Omar Mohammed Ali-Hossain and Noor Hossain remained the most important source of inspiration. In addition, there are many more friends, colleagues, staff and secretaries who have dedicated time to this book-writing project.

# 1

## Introduction

### 1.0 Introduction of the Book

Albert Einstein famously stated, “Scientists investigate that which already is; engineers create that which has never been.” It is no surprise that any engineering project begins with defining a problem. However, the degree and the magnitude of the problems vary due to the nature of an engineering endeavor. Petroleum resources are the lifeline of modern civilization and drilling operations form the most important component of the petroleum industry. As such, drilling engineering has numerous problems, solutions of which are challenging. Added to this complexity is the fact that drilling operations involve the subsurface – clearly out of our sight. In absence of direct evidence, the best a drilling engineer can do is to speculate based on existing geological data and experience of the region. As a result, planning of drilling and its implementation is one of the greatest challenges for planners, administrators, and field professionals. To complete an engineering project, the planning phase must have all possible problem scenarios, followed by projected solutions. This is because once the problem occurs, one doesn’t have the time to figure out the solution impromptu. This book

is designed to help in solving likely problems encountered during drilling operations. Of course, the list of problems is not exhaustive but the science established in solving the problem is comprehensive, thereby allowing operators to draw upon personal experiences and use this book as a guideline. This chapter introduces the fundamental aspects of the drilling problems faced by the drilling operators, drillers, crews, and related professionals in general. It identifies the key areas in which drilling problems are encountered, along with their root causes.

### 1.1 Introduction of Drilling Engineering

Despite recent concerns about their sustainability, petroleum resources continue to be the lifeline of modern civilization. This role of oil and gas will continue in the foreseeable future. Petroleum production is inherently linked to drilling technology, ranging from exploration to production, from monitoring to remediation and environmental restoration. Nearly one-quarter of the petroleum industry's entire exploration and production budget is dedicated to drilling expenses. The complete cycle of petroleum operations includes seismic survey, exploration, field development, hydrocarbon production, refining, storage, transportation/distribution, marketing, and final utilization to the end user. The drilling technology has been developed through the efforts of many individuals, professionals, companies and organizations. This technology is a necessary step for petroleum exploration and production. Drilling is one of the oldest technologies in the world. *Drilling engineering is a branch of knowledge where the design, analysis and implementation procedure are completed to drill a well as sustainable as possible* (Hossain and Al-Majed, 2015). In a word, it is the technology used to unlock crude oil and natural gas reserves. The responsibilities of a drilling engineer are to facilitate the efficient penetration of the subsurface with wellbore and cementing operations that range from the surface to an optimum target depth, while minimizing safety and environmental hazards.

### 1.2 Importance of Drilling Engineering

It is well known that the petroleum industry drives the energy sector, which in turn drives modern civilization. It is not unlikely that every day human beings are getting the benefits out of the petroleum industry. The present modern civilization is based on energy and hydrocarbon resources. The growth of human civilization and necessities of livelihood over time

inspired human beings to bore a hole for different reasons (such as drinking water, agriculture, hydrocarbon extraction for lighting, power generation, to assemble different mechanical parts, etc.). Only a small fraction of petroleum resources is considered to be recoverable and an even tinier fraction of that is available on the surface, making underground resources virtually the only source of hydrocarbons. The flow of oil is ensured only through drilling engineering playing a pivotal role. Naturally, any improvement in drilling practices will bring multifold benefits to the energy sector and much more to the overall economy.

### **1.3 Application of Drilling Engineering**

Throughout human civilization, drilling in numerous forms played a significant role. As such, the applications of drilling technology are numerous. The applications of drilling range from children's toys to modern drilling of a hole for the purpose of any scientific and technological usage. Humans have been using this technology for underground water withdrawal from ancient times. Drilling technology is a widely used expertise in the applied sciences and engineering such as manufacturing industries, pharmaceutical industries, aerospace, military defense, research laboratories, and any small-scale laboratory to a heavy industry, such as petroleum. Modern cities and urban areas use the drilling technology to get the underground water for drinking and household use. The underground water extraction by boring a hole is also used for agricultural irrigation purposes. Therefore, there is no specific field of application of this technology. It has been used for a widespread field based on its necessity. This book focuses only on drilling a hole with the hope of hydrocarbon discovery; therefore, here the drilling engineering application means a shaft-like tool (i.e., drilling rig) with two or more cutting edges (i.e., drill bit) for making holes toward the underground hydrocarbon formation through the earth layers especially by rotation. Hence the major application of drilling engineering is to discover and produce redundant hydrocarbon from a potential oil field.

### **1.4 Drilling Problems, Causes, and Solutions**

The oil and gas industry is recognized as one of the most hazardous industries on earth. Extracting hydrocarbon from an underground reservoir is very risky and uncertain. Therefore, it is very important to find out the root causes of its risk and uncertainty. The majority of the risks and

uncertainties related to this business are encountered while drilling. As a result, drilling problems offer an excellent benchmark for other practices in petroleum engineering as well as other disciplines. However, the key to having a successful achievement of the drilling objectives is to design drilling programs based on anticipation of potential drilling problems. The more comprehensive the list of problems the more accurate the solution manual will become. The best *modus operandi* is to avoid running into a scenario where problems arise. This preventative style will lead to safer and more cost-effective drilling schemes. It is well understood that even one occurrence of the loss of human life, environmental disaster, or loss of rig side area can have a profound effect on the welfare of the entire petroleum industry. Some of the drilling problems comprise of drillpipe sticking, stuck pipe, drillstring failures, wellbore instabilities, hole deviation and well path control, mud contamination, kicks, hazardous and shallow gas release, lost circulation, formation damage, loss of equipment, personnel, and communications. There are some other problems specifically related to slim hole drilling, coiled tubing drilling, extended reach drilling, and under-balance drilling, etc. There is a famous saying, “*prevention is better than cure*”. So, the motto should be “drill a hole safely without having any accident, incident, or harm to this planet, with minimum costs”. The drilling operations should be in a sustainable fashion where the minimization of drilling problems and costs has to have the top priority.

### 1.5 Drilling Operations and its Problems

Globally, modern rotary oil well drilling has been continued for over a century. Although, drilling itself has been a technology known to mankind for millennia (going back to Ancient China and Egypt), the earliest known commercial oil well in the United States was drilled in Titusville, Pennsylvania, in 1857. Before this time, such innovations as 4-legged derrick, “jars”, reverse circulation drilling, spring pole method, and other drilling accessory techniques had been patented. Drake’s famed well itself was drilled with cable tool and reached only 69 ft below the surface – a distance far shallower than drilling feats achieved by water wells. Even though M. C. and C. E. Baker, two brothers from South Dakota, were drilling shallow water wells in unconsolidated formations of the Great Plains, it wasn’t until the late 1800s that the Baker brothers were using rotary drilling in the Corsicana field of Navarro County, Texas. In 1901 Captain Anthony Lucas and Patillo Higgins applied it to their Spindletop well in Texas. By 1925, the rotary drilling method was improved with the use of a diesel engine.

In the meantime, soon after the Drake well, the Sweeney stone drill was patented in 1866. This invention had essential components of modern-day drilling, such as swivel head, rotary drive and roller bit. In terms of drilling bit, the most important discovery was the introduction of the diamond bit. This French invention of 1863 (although ancient Egyptians were known to use such drills in rock quarries) was put in practice to drill a 1,000 ft hole with a 9" diamond bit in 1876. In terms of drilling mud, the history of early oil wells indicates that natural drilling mud was used, with the addition of locally available clay. It is conceivable that early engineers learned the technique of drilling mud operations by observing the fact that as water collected in situ mud from the formation its ability to clean the wellbore increases. However, the use of mud was formalized by the U.S. Bureau of Mines in 1913, soon after which significant changes to mud chemistry were invoked. By the 1920s, natural clay was substituted in favor of barite, iron oxide, and mined bentonite clays. With the introduction of a commercial drilling mud company (NL Baroid), mud chemistry has evolved drastically to make access to deeper formations possible (Barrett, 2011). The next quantum leap would come in the 1970s when conventional drilling mud materials were deemed unsafe for the environment and new regulations were introduced. The tradition of environment-friendly drilling operations began.

Today's sophisticated techniques are allowing unreachable formations to extract hydrocarbon beyond vertical and direction wells. In the 1980s, the petroleum industry went through a revolution during which period horizontal well technology was introduced and perfected. At present, drilling companies can drill vertically, directionally, and horizontally using the available technologies with an unprecedented precision and speed. However, there are gaps in these quantum leaps and certain aspects of drilling remain improvised and in need of modernization. These areas have been skipped because the primary focus of the last few decades has been automation and control rather than overall effectiveness of the drilling operation. Once a drilling site is identified, a drilling team starts to make preparations of rig installation prior to drilling. During the whole process of drilling, there might be numerous problems such as technical, geological, geographical, manpower, management, financial, environmental, and political. This book is limited to a focus on technological, geological and environmental problems and their solutions.

### **1.5.1 Common Drilling Problems**

Farouq Ali famously wrote, "It's easier to land a man on the moon than describing a petroleum reservoir" (JPT, 1970). Indeed, the petroleum industry is the

only one that doesn't have the luxury of 'field visit' or 'field inspection'. In the drilling industry, the most evident problem is the nature of the job itself. The obvious challenge is that we cannot see with our naked eyes what is really happening inside the subsurface. Even if we plan very carefully, it is almost certain that problems related to drilling operations will happen while drilling a well. Understanding and anticipating drilling problems, understanding their causes, and planning solutions are necessary for an overall well cost control which ensures successfully reaching the target zone.

The most prevalent drilling problems include pipe sticking, lost circulation, hole deviations and directional control, pipe failures, borehole instability, mud contamination, formation damage, annular hole cleaning, hazardous gas and shallow gas (i.e.,  $H_2S$ -bearing formation and shallow gas), cave-in hole (collapse), bridging in wells, crookedness of wells/deflection of wells, mud cake formation, pollution and corrosion in wells, stacked tools, drillstring failures, kicks, slow drilling, formation damage, and equipment, communications and personnel-related problems. There are some specific problems related to directional drilling which cover directional/horizontal well drilling, multilateral well drilling, coiled tubing drilling, under-balanced drilling, slim hole drilling. To get the true benefits after knowing the real problems and their solutions, we have to know the answers to the following: i) what problems are to be expected, ii) how to recognize the problem signals, iii) what courses of action need to be taken to combat these problems quickly and economically, and iv) how to employ the learning from the experiences and best real-world solutions. The direct benefit of these answers will have an impact on reducing overall drilling cost, assurance of an economically successful hydrocarbon recovery, and improving the performance of the overall well construction.

## 1.6 Sustainable Solutions for Drilling Problems

Drilling is a necessary step for petroleum exploration and production. However, drilling into a formation that is thousands of meters underground with extremely complex lithology is a daunting task. The conventional rotary drilling technique falls short since it is costly and contaminates surrounding rock and water due to the use of toxic drilling fluids. The overall approach that includes the usage of toxic chemicals as determined in the 1970s continues to be in operation. In view of increased awareness of the environmental impact, efforts are being made for making drilling practices sustainable (Hossain and Al-Majid, 2015). To make the process sustainable and environmentally friendly, however, is an extremely challenging



task. It involves making fundamental changes in engineering practices that have been in place ever since the plastic revolution took place over a century ago. This is the most difficult challenge faced by the petroleum industry tasked with reducing environmental impact of petroleum operations. Recent advances in the petroleum industry have made it possible to have a drilling technique that meets both technical and environmental challenges. Such solutions were considered to be an impossible task only a decade ago. For example, sustainability is one of the prime requirements for greening the drilling fluid system. However, it is a challenge for us how to green the drilling fluid because it depends on the source/origin of the base materials, additives, technology used, and the process itself. Therefore, the development of a sustainable drilling operations and green fluid requires a thorough cost-effective investigation.

In this globalization era, technology is changing every day. Due to the continuous changes and competition between the organizations, it is becoming a challenge for saving this planet. As a result, in management, a sustainable organization can be defined as an organization where exist i) political and security drivers and constraints, ii) social, cultural and stakeholder drivers and constraints, iii) economic and financial drivers and constraints, and iv) ecological drivers and constraints. Thus sustainability concept is the vehicle for the near future Research & Development (R&D) for technology development. A sustainable technology will work towards natural process. In nature, all functions or techniques are inherently sustainable, efficient and functional for an unlimited time period (i.e.  $\Delta t \rightarrow \infty$ ). By following the same path as the function inherent in nature, some recent research shows how to develop a sustainable technology (Appleton, 2006, Hossain *et al.*, 2010; Hossain, M.E., 2011; Hossain, M.E., 2013; Khan *et al.*, 2005; Khan and Islam, 2005; Khan 2006a and 2006b). The success of a high-risk hydrocarbon exploration and production depends on the use of appropriate technologies.

Generally, a technology is selected based on criteria, such as technical feasibility, cost effectiveness, regulatory requirements and environmental impacts. Khan and Islam (2006a) introduced a new approach in technology evaluation based on the novel sustainability criterion. In their study, they not only considered the environmental, economic and regulatory criteria, but investigated sustainability of technologies (Khan *et al.*, 2005; Khan and Islam, 2005; Khan 2006a and 2006b). “Sustainability” or “sustainable technology” has been used in many publications, company brochures, research reports and government documents which do not necessarily give a clear direction (Khan, 2006a; Appleton, 2006). Sometimes, these conventional approach/definitions mislead to achieve true sustainability.

Engineering is an art that needs conscious participation and skillful mentoring. The best way to learn how to handle an engineering problem is to sit down next to a friendly, patient, experienced practitioner and work through problems together, step-by-step. Matters of research in fundamentals of drilling engineering, complete with knowledge and most up-to-date information are extremely useful in designing a sustainable drilling well design which ultimately help in reducing the drilling problems in general.

The lack of proper training in environmental sustainability has caused tremendous frustration in the current energy management sector. While everyone seems to have a solution, it is increasingly becoming clear that these options are not moving our environment to any cleaner state. This book offers some of the advanced and recent achievements related to drilling operation problems in addition to fundamentals of different drilling-related problems and sustainable operations. Relevant parameters, ranging from drilling fluid properties to rock heterogeneity will be discussed and methods presented to make the operation sustainable. Complexities arising from directional and horizontal wells in difficult-to-drill formations will be discussed in order to offer practical solutions for drilling problems.

## 1.7 Summary

This chapter discusses some of the core issues related to drilling engineering. Starting with the history of petroleum well drilling, the chapter introduces various topics of drilling engineering, as presented in this book. Topics include, even before starting drilling operations, different types of drilling problems, and the concept of sustainable drilling operations.

## References

- Appleton, A.F., 2006. Sustainability: A practitioner's reflection, *Technology in Society*, vol. 28, pp. 3–18
- Barrett, Mary L., 2011, Drilling Mud: A 20th Century History, *Oil-Industry History*, v. 12, no. 1, 2011, pp. 161–168.
- Canada Nova Scotia Offshore Petroleum Board. 2002. Environmental Protection Board. White Page. <<http://www.cnsopb.ns.ca/Environment/environment.html>> (Cited: April 21, 2002).
- EPA, 2000. Development document for final effluent limitations guidelines and standards for synthetic-based drilling fluids and other non-aqueous drilling fluids in the oil and gas extraction point source category. United States Environmental Protection Agency. Office of Water, Washington DC 20460, EPA-821-B-00-013, December 2000.

- Holdway, D.A., 2002. The Acute and Chronic Effects of Wastes Associated with Offshore Oil and Gas Production on Temperature and Tropical Marine Ecological Process. *Marine Pollution Bulletin*, Vol. 44: 185–203.
- Hossain, M.E., Ketata, C., Khan, M.I. and Islam, M.R., “A Sustainable Drilling Technique”, *Journal of Nature Science and Sustainable Technology*. Vol. 4, No. 2, (2010), pp.73 – 90.
- Hossain, M.E. (2013), “Managing drilling waste in a sustainable manner”, presented as an invited speaker from the Middle East Region in the conference on Drilling Waste: Manage, Reduce, Recycle, organized by the Drilling Waste Forum, 8 – 11 December, 2013, Beach Rotana Hotel, Abu Dhabi, U.A.E.
- Hossain, M.E., “Development of a Sustainable Diagnostic Test for Drilling Fluid”, Paper ID – 59871, Proc. of the International Symposium on Sustainable Systems and the Environment (ISSE) 2011, American University of Sharjah, Sharjah, UAE, March 23–24, 2011.
- Hossain, M.E. and Al-Majed, A.A. (2015). *Fundamentals of Sustainable Drilling Engineering*. ISBN 978-0-470878-17-0, John Wiley & Sons, Inc. Hoboken, New Jersey, and Scrivener Publishing LLC, Salem, Massachusetts, USA, pp. 786.
- Khan, M.I, and Islam, M.R., 2003a. Ecosystem-based approaches to offshore oil and gas operation: An alternative environmental management technique. SPE Conference, Denver, USA. October 6–8, 2003.
- Khan, M.I, and Islam, M.R., 2003b. Wastes management in offshore oil and gas: A major Challenge in Integrated Coastal Zone Management. ICZM, Santiago du Cuba, May 5–7, 2003.
- Khan, M.I, Zatzman, G. and Islam, M.R., 2005. New sustainability criterion: development of single sustainability criterion as applied in developing technologies. Jordan International Chemical Engineering Conference V, Paper No.: JICEC05-BMC-3–12, Amman, Jordan, 12 - 14 September 2005.
- Khan, M.I. and Islam, M.R. 2005. Assessing Sustainability of Technological Developments: An Alternative Approach of Selecting Indicators in the Case of Offshore Operations. ASME Congress, 2005, Orlando, Florida, Nov 5–11, 2005, Paper no.: IMECE2005–82999.
- Khan, M.I, Zatzman, G. and Islam, M.R., 2005. New sustainability criterion: development of single sustainability criterion as applied in developing technologies. *Jordan International Chemical Engineering Conference V*, Paper No.: JICEC05-BMC-3–12, Amman, Jordan, 12 - 14 September 2005.
- Khan, M.I. and Islam, M.R. 2005. Assessing Sustainability of Technological Developments: An Alternative Approach of Selecting Indicators in the Case of Offshore Operations. *ASME Congress*, 2005, Orlando, Florida, Nov 5–11, 2005, Paper no.: IMECE2005–82999.
- Khan, M.I. and Islam, M.R., 2006a. *Achieving True Sustainability in Technological Development and Natural Resources Management*. Nova Science Publishers, New York, USA, pp 381
- Khan, M.I. and Islam, M.R., 2008. *Petroleum Engineering Handbook: Sustainable Operations*. Gulf Publishing Company, Texas, USA, pp 461.

- Khan, M.I. and Islam, M.R., 2006b. *Handbook Sustainable Oil and Gas Operations*. Gulf Publishing Company, Texas, USA.
- Patin, S., 1999. *Environmental impact of the offshore oil and gas industry*. EcoMonitor Publishing, East Northport, New York. 425 pp.
- Veil, J.A., 2002. Drilling Waste Management: past, present and future. SPE paper no. 77388. Annual Technical Conference and Exhibition, San Antonio, Texas, 29 September-2 October.
- Waste Management Practices in the United States, prepared for the American Petroleum Institute, May 2002.

# 2

## Problems Associated with Drilling Operations

### 2.0 Introduction

The rotary drilling rig and its components are the major vehicle of modern drilling activities. In this method, a downward force is applied on the drill bit that breaks the rock with both downward force and centrifugal force, thereby forming the pivotal part of an effective drilling operation. The conventional practice in the oil industry is to use robust drillstring assembly for which large capital expenses are required. However, during any drilling operation, numerous challenges are encountered, each of which can have significant impact on the time required to complete a drilling project. Often, one problem triggers another problem and snowballing of problems occurs, thus incapacitating the drilling process. In this process, there is no 'small' or 'large' problem, as all problems are intricately linked to each other, eventually putting safety and environmental integrity in jeopardy. Any such impact has immeasurable financial impact beyond short-term effects on the 'time loss.' This chapter discusses some of the generic drilling problems, such as H<sub>2</sub>S-bearing zones and shallow gas, equipment and personnel, objects dropped into the well, resistant beds encountered, fishing operations,

junk retrieve operations, and twist-off. It identifies the key areas where we encounter drilling problems, their root causes, and solutions related to drilling methods. In well planning, the key to achieving objectives successfully is to design drilling programs on the basis of anticipation of potential hole problems rather than on caution and containment. The desired process is to preempt any problem, because drilling problems can be very costly after they occur. The most prevalent drilling problems include pipe sticking, lost circulation, hole deviation, pipe failures, borehole instability, mud contamination, formation damage, hole cleaning,  $H_2S$ -bearing formation and shallow gas, and equipment and personnel-related problems.

## 2.1 Problems Related to Drilling Methods and Solutions

### 2.1.1 Sour Gas Bearing Zones

During drilling and workover operations, the consequences of leaks with sour gas or crude may be devastating. Drilling  $H_2S$ -bearing formations poses one of the most difficult and dangerous problems to humans and equipment. Personnel can be injured or even killed by relatively low concentrations of  $H_2S$  in a very short period of time. Equipment can experience terrible failure due to  $H_2S$  gas-induced material failure. This risk depends primarily on the  $H_2S$  content with the formation fluids, formation pressure, and the production flow rate. This information is used to assess the level of risk from the presence of  $H_2S$ . In addition, if this risk is known or anticipated, there are very specific requirements to abide by in accordance to International Association of Drilling Contractors (IADC) rules and regulations. All information will ultimately lead to the requirement for special equipment, layout, and emergency procedures for drilling and/or workover operations.

#### 2.1.1.1 How to Tackle $H_2S$

The presence of  $H_2S$  can be anticipated from previous data on the field, or from the region. For a wildcat, all precautionary measures should be taken, following IADC rules, as if  $H_2S$  will be encountered. The following steps and the plans should be followed while  $H_2S$  gas is encountered.

#### i) *Planning of operations*

- A study should be done on geological and geographical information of the area. This study should include history

of adjacent wells in order to predict the expected area where  $H_2S$  may be encountered. Information should be obtained and taken into consideration about the area and known field conditions, including temperatures, pressures, proposed well depth, and  $H_2S$  concentrations.

- A mud program should be drawn up which will provide different pressures expected to be encountered. However,  $H_2S$  scavenger should also be included to reduce the reaction of  $H_2S$  on the drillstring and related equipment to control the processing of  $H_2S$  at surface. Normal practice is to maintain a higher than normal pH (i.e., 10.5–11) and to treat the mud with a suitable scavenger as soon as dissolved sulphides are analyzed. The contamination of water-based muds due to  $H_2S$  can deteriorate the mud properties at a fast rate. It is advisable to keep the mud moving with immediate treatment to maintain the desired properties.
- Maintaining a high pH or using a scavenger is not suitable to safeguard drilling equipment against  $H_2S$ , since in a kick situation the wellbore may become partially/fully devoid of drilling fluid, thus reducing or eliminating the ability to contact drillstring and wellhead and BOP components with scavenger.  $H_2S$  resistant materials should be considered for this well control condition. The BOPs must be made to NACE specifications that conform to the presence of  $H_2S$ .
- Prior to reaching the  $H_2S$ -bearing formations, the emergency equipment (blowout preventer, degasser, etc.) and response procedures should be tested in an exercise that simulates a kick.
- Wind direction should be considered for the layout of equipment such as shale shakers, choke manifold, mud tanks, and particularly vents such as flare lines, degasser vents, mud-gas separator vents, and diverter lines. Wind socks on the site or platform should enable identification of upwind assembly points. For offshore operations, each assembly point should allow easy evacuation from the installation.

### ***ii) Drilling equipment selection***

Equipment should be selected after consideration of metallurgical properties, thus reducing the chances of failure from  $H_2S$ -induced corrosion. The following recommendations are to be followed for  $H_2S$  designated wells:

#### **a. BOP stack**

- Metallic materials for sour-gas service should be employed.

## 14 DRILLING ENGINEERING PROBLEMS AND SOLUTIONS

- All pressure containing components of the BOP stack with the potential to be exposed to  $H_2S$  should be manufactured with the material, which meets the standard of the NACE MR-01-75 and API RP 53. These components include annular preventer, rams, drilling spools, the hydraulic operated choke line valve, and gaskets, etc.
  - Non-metallic materials for sour service.
  - Non-metallic materials for sour service should conform to API RP 53, Section 9. A.8. Fluoropolymers, such as Teflon or Ryton and fluoroelastomers, such as viton or Kalrez are acceptable materials.
  - Welding should conform to sour-gas service.
  - Where welding is required for component fabrication, the welding and the heat affected zone of the welded components should possess essentially the same chemical and physical properties as the parent metals of the subcomponents. These include hardness properties and impact properties where appropriate. The welding is also required to be free of linear defects such as cracks, undercutting, and lack of fusion.
  - Sour-gas service identification should be performed.
  - Components should be marked in a manner that shows their suitability, under NACE MR-01-75, for sour service.
  - Identification stamping procedures as detailed in NACE MR-01-75, Section 5.4 should be followed.
  - Transportation, rigging up, and maintenance should conform to sour-gas requirements.
  - During transportation, rigging up, and maintenance of BOP stacks, operating practices should be used to avoid cold temperature that might induce hardening of equipment components. Material control for replacement parts for the BOP stack should have specifications and quality control equivalent to the original equipment.
- b. Flange, bonnet cover, bolting, and nut material
- Each of these intended for  $H_2S$  use should meet requirements prescribed in API Specification 6A section 1.4 (14<sup>th</sup> edition).
- c. Choke manifold
- Piping, flanges, valves, fittings, and discharge lines (flare lines) used in the composition of the choke manifold



assembly should contain metals and seals in accordance with API RP 53.

d. Degassers/mud-gas separator

- The degasser should be capable of effectively removing entrained gases from contaminated drilling fluid circulated back to the surface. The vent outlet on the degasser should be extended so that the extracted gas can be routed to a remote area for flaring or connected into the choke flare line. A mud-gas separator is used to extract gas containing  $H_2S$  from drilling fluids. This separator should be tied into a vent line for burning so that it cannot release the gas into the atmosphere close to the rig side area.

e. Flare lines

- Flare lines should be installed from the degasser, choke manifold, and mud-gas separator according to API RP 49. All flare lines should be equipped with the means for constant or automatic ignition.

f. Drillpipe

- Because of the direct contact of drillpipe with  $H_2S$  in the wellbore where various temperature and pressure conditions exist, the lower grades of pipe should be used so as to minimize hydrogen embrittlement or sulphide stress corrosion cracking (SSCC). Means of control to minimize hydrogen embrittlement and SSCC of drillpipe can also be found in API RP 49. Consideration may be given to the use of a drillstring equipped with special tool joint material.

g. Monitoring equipment

- Each drilling rig operating in an area known or suspected to produce  $H_2S$  gas should have adequate  $H_2S$  monitoring and/or detection equipment. It is recommended that this equipment should be installed 350 meters and/or one week prior to drilling into the  $H_2S$  zone.  $H_2S$  concentrations should be continuously monitored at strategic sampling positions, e.g., shale shaker, mud ditch, mud tank area, etc., and results transmitted both to the driller's console and to the toolpusher's office. Audible and visible alarms should indicate both locally and remotely when  $H_2S$  concentration reaches 10 ppm. Sulphide tests should be carried out as part of the mud testing program in areas where hydrogen sulphide gas ( $H_2S$ ) might be encountered.

## h. Mud logging unit

- The mud logging unit and equipment should be located away from the shaker tank and a minimum of 50 meters distance should be kept from the well head.

## i. Venting system

- Weatherized rigs equipped with partitions permanent in nature should be provided with a ventilation system sufficient for the removal of accumulated  $H_2S$ .

**iii) Training**

When drilling in an area where  $H_2S$  gas might be encountered, training of personnel must be carried out on the subject matter. The action should be taken in the event of alarm, the use of safety equipment, and escape procedures whatever the likelihood of encountering  $H_2S$ . Emergency procedures must be practiced regularly, using realistic emergency drills.

**iv)  $H_2S$  contingency planning**

A contingency plan should be drawn up when  $H_2S$  is anticipated while drilling. The contingency plan should be developed prior to the commencement of drilling operations and should include the following:

- Information on the physical effects or exposure to  $H_2S$  and sulphur dioxide ( $SO_2$ ).
- Safety and training procedures should be followed and safety equipment will be used.
- Procedures for operations when the following conditions exist:
  - pre-alarm condition
  - moderate danger to life
  - extreme danger to life
- Responsibilities and duties of personnel for each operating condition.
- Briefing areas or locations for assembly of personnel during extreme danger condition should be designated. At least two briefing areas should be established on each drilling facility. Of these two areas, the one upwind at any given time is the safe briefing area.
- Evacuation plan should be in place and well rehearsed.
- Plan must be in place as to who would notify the authority and at what stage of the incident.

- A list of emergency medical facilities, including locations and/or addresses and telephone numbers must be in place.
- In a pre-spud meeting, the company drilling supervisor should review the drilling program with the drilling contractor and service contractors, outlining each party's responsibility in drilling a well, where H<sub>2</sub>S may be encountered.
- All personnel should be fully trained and the H<sub>2</sub>S-related equipment should be in place when drilling at 350 meters above and/or one week prior to encountering a hydrogen sulphide zone.
- Available literature should be carefully studied before drawing up H<sub>2</sub>S procedures. Recommended references are: API RP49 "Safe Drilling of Wells Containing Hydrogen Sulphide."

### 2.1.2 Shallow Gas-Bearing Zones

Shallow gas-bearing zone is defined as any hydrocarbon-bearing zone, which may be encountered at a depth close to the surface or mudline. In generally, it is not possible to close in and contain a gas influx from a shallow zone because weak formation integrity may lead to breakdown and broaching to surface and/or mudline. This situation is particularly hazardous when drilling operations continue from a fixed installation or jack-up rig. Shallow gas-bearing zones are usually in a pressured condition. However, the effective increase in pore pressure due to gas gradient can lead to underbalance when a shallow gas zone is first penetrated.

Shallow gas may be encountered at any time in any region of the world. The only way to control this problem is that we should never shut in the well. It is also needed to divert the gas flow through a diverter system at the BOP. High-pressure shallow gas can be encountered at depths as low as a few hundred feet where the formation-fracture gradient is very low. The danger is that if the well is in shut-in condition, formation fracturing is more likely to occur. This will result in the most severe blowout problem, and ultimately an underground blow.

The identification and avoidance of shallow gas will be a principal objective in well planning and site survey procedures. All drilling programs shall contain a clear statement on the probability and risk of encountering shallow gas. This will be based on seismic survey and interpretation together with offset geological and drilling data. For onshore operations, consideration should be given for carrying out shallow seismic surveys in areas of shallow gas risk. In the absence of such surveys, assessment should be based on the exploration seismic data, historical well data, and the geological probability of a shallow gas trap. If shallow gas is a likelihood at

the proposed drilling location, a shallow gas plan specific to company and the drilling contractor must be prepared prior to spudding the well. Special consideration should be given to: crew positions, training, evacuation plan, and emergency power shut down. For offshore operations, the presence of shallow gas can be extremely hazardous especially if no specific plan of action is prepared prior to spudding of the well. The driller will be instructed in writing on what action should be taken if a well kick should be noticed while drilling. The problem of drilling a shallow hole is that normal indications of a kick are not reliable. For example, penetration rates vary tremendously, and mud volume is continuously being added to the active system. The most reliable indicator is the differential flow sensor. Due to the difficulties of early detection and the depth of shallow gas reservoirs, reaction time is minimal. In such case, extreme caution, and alertness are required.

#### *2.1.2.1 Prediction of Shallow Gas Zone*

Although the location of gas pockets is difficult to predict, high-resolution seismic data acquisition, processing and interpretation techniques increase the reliability of the shallow gas prognosis. Therefore, surveys are to be recommended. Well proposals should always include a statement on the probability of encountering shallow gas, even if no shallow gas is present. This statement should not only use the “shallow gas survey”, but also include an assessment drawn from the exploration seismic data, historical well data, the geological probability of a shallow cap rock, coal formations, and any surface indications/seepages. The shallow gas procedures based on the shallow gas statement in the well proposal, and practical shallow gas procedures should be prepared for that particular well. The following guidelines should be adhered to avoid influx and kick: i) avoid shallow gas where possible; ii) optimize the preliminary shallow gas investigation; iii) the concept of drilling small pilot holes for shallow gas investigation with a dedicated unit is considered an acceptable and reliable method of shallow gas detection and major problem prevention; iv) surface diverter equipment is not yet designed to withstand an erosive shallow gas flow for a prolonged period of time. Surface diverters are still seen as a means of “buying time” in order to evacuate the drilling site; v) diverting shallow gas in subsea is considered to be safer as compared to diverting at surface, vi) dynamic kill attempt with existing rig equipment may only be successful if a small pilot hole (e.g., 9 7/8” or smaller) is drilled and immediate pumping at maximum rate is applied in the early stage of a kick; and vii) riserless top hole drilling in floating drilling operations is an acceptable and safe method.

### 2.1.2.2 *Identification of Shallow Gas Pockets*

While drilling at shallow depth in a normally pressured formation, no indication of a gas pocket can be expected other than higher gas readings in the mud returns. Since the overbalance of the drilling fluid at shallow depths is usually minimal, pressure surges may cause an underbalanced situation which could result in a kick. Therefore, every attempt should be made to avoid swabbing. Some definitions are used to describe the risk in shallow gas assessment, such as i) high: an anomaly showing all of the seismic characteristics of a shallow gas anomaly, that ties to gas in an offset well, or is located at a known regional shallow gas horizon, ii) moderate: an anomaly showing most of the seismic characteristics of a shallow gas anomaly, but which could be interpreted not to be gas and, as such reasonable doubt exists for the presence of gas, iii) low: an anomaly showing some of the seismic characteristics of a shallow gas anomaly, but that is interpreted not to be gas although some interpretative doubt exists, and iv) negligible: either there is no anomaly present at the location or anomaly is clearly due to other, nongaseous, causes.

There are two factors that make shallow gas drilling a difficult challenge. First, unexpected pressure at the top of the gas-bearing zone, most often due to the “gas effect” dictated by zone thickness and/or natural dip, can be significant. This pressure is usually unknown, seismic surveys being often unable to give an idea either about thickness or in-situ gas concentration. In more complex situations, deep gas may migrate upwards along faults. For example, the influx in Sumatra could not be stopped even with 10.8 ppg mud at very shallow depth because the bit had crossed a fault plane. Second, low formation fracture gradients are a predominant factor in shallow gas operations.

These two factors result in reduced safety margin for the driller. Minor hydrostatic head loss (e.g., swabbing, incorrect hole filling, cement slurry without gas-blocking agent), any error in mud weight planning (e.g., gas effect not allowed for), or any uncontrolled rate of penetration with subsequent annulus overloading will systematically and quickly result in well bore unloading. Shallow gas flows are extremely fast-developing events. There is a short transition time between influx detection and well unloading, resulting in much less time for driller reaction and less room for error. Poor quality and reliability of most kick-detection sensors worsen problems.

Previous history has disclosed the magnitude of severe dynamic loads applied to surface diverting equipment, and consequent high probability of failure. One of the associated effects is erosion, which leads to high potential of fire hazards and explosion from flow impingement on rig facilities.

The risk of cratering is a major threat against the stability of bottom-supported units. As it is impossible to eliminate them (i.e., most shallow gas-prone areas are developed from bottom supported units), emphasis should be put on careful planning and close monitoring during execution.

2.1.2.3 Case Study

**Description:** Four new wells were drilled at an offshore platform with casing on the surface section in batch-drilling mode. 13<sup>3</sup>/<sub>8</sub>-in casing shoes were set as per plan in a range from 1,800 to 2,000 ft for the four wells (Figure 2.1). All the risk-control measures resulting from the risk-analysis exercise were implemented when drilling the section. In the first well, logging-while-drilling tools were included in the bottomhole assemblies (BHA). There were no indications of a shallow gas zone.

**Drilling Plan:** The plan was to use seawater for the four wells because the drilling fluid was for the casing-drilling operation.

**Drilling Operations and Potential Problems:** Pumping sweeps were performed at every connection to help with hole cleaning. Following the plans, the first of the four wells was drilled with seawater and sweeps. Soon after drilling out of the conductor, fluid losses were experienced.

**First Aid Remedy and Consequences:** Loss-control material was pumped downhole and drilling continued, expecting the coating effect to contribute in building a mudcake that would eventually cease the losses. Drilling-fluid

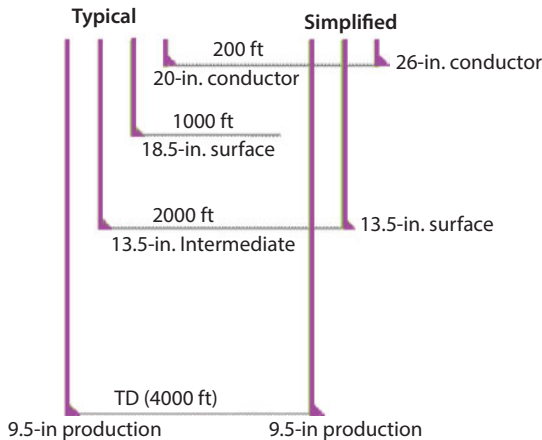

Figure 2.1 Placement of casing.

losses decreased but did not stop until section total depth (TD) was reached and casing was cemented. In addition, when drilling the first well, accurate position surveys were taken, which required several attempts at every survey station. These attempts were due to the poor data transmission from measurement-while-drilling (MWD) tools. The result was an increase of 10% non-productive (e.g., off-bottom) drilling time compared with other wells. The problems with the MWD transmission also affected the resistivity and gamma ray data that were planned to provide early information of any shallow gas accumulation. As a result, it was difficult to interpret the real-time data provided by the logging tool.

**Final Solution:** The engineering team decided to change the drilling fluid from seawater to a low-viscosity mud. They were expecting to build a better mudcake and to improve fluid-loss control. To improve the MWD transmission, a low telemetry rate was set on the tools to reduce the time required to take a survey. These measures contributed to drill the next three wells with no drilling-fluid losses and with no delays from a lengthy survey procedure.

**Lesson Learned:** The seawater-and-sweeps system was replaced with a low viscosity water-based-mud drilling fluid after the problems that had been faced in the first well. As a result, the three remaining wells were drilled with improved drilling practices. Severe fluid losses were not observed, and the quality of the telemetry signal improved substantially. A possible explanation for the problems with the use of seawater are: i) drilling fluid does not have the required properties to create a consistent mudcake around the wellbore wall, ii) the use of seawater also induced turbulent flow, which may give good hole cleaning but would increase the hole washouts in shallow formations. An enlarged wellbore and the inability to create an optimum mudcake might have eliminated the coating effect and the expected improvements in terms of loss control. Problems with the telemetry-signal quality were attributed to the telemetry rate setup and the noise created by the drilling fluid. Setting a low telemetry rate in the MWD proved useful for adapting to the particular condition of casing drilling, where the internal diameter in the drillstring experiences great variations, such as 2.8 in. at the BHA and 12.6 in. for the rest of the string.

**Personal Experiences:** The following are the field experience for diverter procedures while drilling a top hole. At first sign of flow,

1. Do not stop pumping.
2. Open diverter line to divert/close diverter (both functions should be interlocked).

3. Increase pump strokes to a maximum limit (DO NOT exceed maximum pump speed recommended by the manufacturer or maximum pressure allowed by relief valve).
4. Switch suction on mud pumps to heavy mud in the reserve pit. Zero stroke counter.
5. Raise alarm and announce emergency using the PA system and/or inform the rig superintendent. Engage personnel to look for gas (Jack-up).
6. If the well appears to have stopped flowing after the heavy mud has been displaced stop pumps and observe well.
7. If the well appears to continue to flow after the heavy mud has been pumped, carry on pumping from the active system and prepare water in a pit for pumping and/or consider preparing pit with heavier mud. When all mud has been consumed, switch pumps to water. Do not stop pumping for as long as the well continues to flow.

**General Guidelines for Drilling Shallow Gas:** The following guidelines shall be adhered to while drilling:

- Consideration shall be given to drilling a pilot hole with the 8 ½” or smaller bit size when drilling explorations wells. The BHA design shall include a float valve and considerations should be given to deviation and subsequent hole opening. The major advantages of a small pilot hole are: i) the Rate of Penetration (ROP) will be controlled to avoid overloading the annulus with cuttings and inducing losses, ii) all losses shall be cured prior to drilling ahead. Drilling blind or with losses requires the approval from head of operations, iii) pump pressure shall be closely monitored and all connections (on jack-up) shall be flow checked, iv) pipe shall be pumped out of hole at a moderate rate to prevent swabbing.

**General Recommended Drilling Practices in Shallow Gas Areas:** Common drilling practices, which are applicable for top hole drilling in general and diverter drilling in particular are summarized below. Recommendations are made with a view to simplify operations, thereby minimizing possible hole problems.

- A pilot hole should be drilled in areas with possible shallow gas, because the small hole size will facilitate a dynamic well killing operation.



- The penetration rate should be restricted. Care should be taken to avoid an excessive build-up of solids in the hole that can cause formation breakdown and mud losses. Drilling with heavier mud returns could also obscure indications of drilling through higher pressured formations. The well may kick while circulating the hole cleaning. Restricted drilling rates also minimize the penetration into the gas-bearing formation which in turn minimizes the influx rate. An excessive drilling rate through a formation containing gas reduces the hydrostatic head of the drilling fluid, which may eventually result in a flowing well.
- Every effort should be made to minimize the possibility of swabbing. Pumping out of the hole at optimum circulating rates is recommended for all upward pipe movements (e.g., making connections and tripping). Especially in larger hole sizes (i.e., larger than 12”), it is important to check that the circulation rate is sufficiently high and the pulling speed is sufficiently low to ensure that no swabbing will take place. A top drive system will facilitate efficient pumping out of hole operations. The use of stabilizers will also increase the risk of swabbing; hence the minimum required number of stabilizers should be used.
- Accurate measurement and control of drilling fluid is most important in order to detect gas as early as possible. Properly calibrated and functioning gas detection equipment and a differential flowmeter are essential in top hole drilling. Flow checks are to be made before tripping. At any time, a sharp penetration rate may increase or tank level anomaly may be observed. When any anomaly appears on the MWD log, it is recommended to flow check each connection while drilling the pilot hole in potential shallow gas areas. Measuring mud weight in and out, and checking for seepage losses are all important practices which shall be applied continuously.
- A float valve must be installed in all BHAs which are used in top hole drilling in order to prevent uncontrollable flow up the drillstring. The float valve is the only down-hole mechanical barrier available. The use of two float valves in the BHA may be considered in potential shallow gas areas.
- Large bit nozzles or no nozzles and large mud pump liners should be used to allow lost circulation material (LCM) to be pumped through the bit in case of losses. Large nozzles are

also advantageous during dynamic killing operations, since a higher pump rate can be achieved. For example, a pump rate of approximately 2,700 l/min at 20,000 kPa pump pressure can be obtained using a 1300–1600 HP pump with  $3 \times 14/32$ " nozzles installed in the bit. By using  $3 \times 18/32$ " nozzles, the pump rate can be increased to around 3,800 ltr/min at 20,000 kPa. The use of centre nozzle bits will increase the maximum circulation rate even further and also reduces the chance of bit balling.

- Shallow kick-offs should be avoided in areas with probable shallow gas. Top hole drilling operations in these areas should be simple and quick to minimize possible hole problems. BHAs used for kick-off operations also have flow restrictions which will reduce the maximum possible flow through the drillstring considerably. A successful dynamic well killing operation will then become very unlikely.

### 2.1.3 General Equipment, Communication, and Personnel Related Problems

Most drilling problems result from unseen forces in the subsurface. The major causes of these problems are related to equipment, gap in proper communication, and issues related to human errors (personnel-related). However, there are drilling problems that are directly related to formation, operational hazard, and geology. This section discusses the equipment, communication, and personnel-related problems.

#### 2.1.3.1 Equipment

The integrity of drilling equipment and its maintenance are major factors in minimizing drilling problems. However, the equipment involved can also be a source of problems in addition to communication and personnel-related issues. Drilling problems can significantly be reduced by proper rig hydraulics (i.e., pump power) for efficient mud circulation, proper hoisting power for efficient tripping out, proper derrick design loads and drilling line tension load to allow safe overpull in case of a stuck pipe problem, and well-control systems (ram preventers, annular preventers, internal preventers) that allow kick control under any kick situation. Specific mud properties and required horsepower are needed for bottom hole and annular space cleaning, proper gel strength to hold the cuttings. Proper monitoring and recording systems are necessary to monitor trend changes in all drilling parameters and can retrieve drilling data at a later date. Proper tubular

hardware is specifically required to accommodate all anticipated drilling conditions. Effective mud-handling and maintenance equipment will ensure the mud properties that are designed for their intended functions. The following drilling equipment may create potential drilling problems while drilling: i) rig pumps, ii) solids control equipment, iii) the rotary system, iv) the swivel, v) the well control system, and vi) offshore drilling. In the majority of cases, equipment failure may happen due to corrosion in addition to bending, fatigue, and buckling.

The integrity of drilling equipment and its maintenance are major factors in minimizing drilling problems. The following are all necessary for reducing drilling problems:

- Proper rig hydraulics (pump power) for efficient bottom and annular hole cleaning
- Proper hoisting power for efficient tripping out
- Proper derrick design loads and drilling line tension load to allow safe overpull in case of a sticking problem
- Well-control systems that allow kick control under any kick situation (i.e., proper maintenance of ram preventers, annular preventers, and internal preventers)
- Proper monitoring and recording systems that monitor trend changes in all drilling parameters and can retrieve drilling data at a later date
- Proper tubular hardware specifically suited to accommodate all anticipated drilling conditions
- Effective mud-handling and maintenance equipment (i.e., it will ensure that the mud properties are designed for their intended functions)

#### 2.1.3.1.1 Case Study

Inspection of the below-grade wellhead equipment has shown corrosion damage to the buried landing base, casing spools and surface casing, especially in water injection and supply wells in onshore fields in the Middle East. Occurrence of corrosion damage has been a concern in the buried wellhead equipment and surface casing immediately below the landing base in the onshore fields. Initial random inspections of the below-grade wellhead equipment in the mid-eighties showed corrosion damage to the buried landing base, casing spools, and surface casing. Typical landing base and surface casing equipment for onshore wells is depicted in Figure 2.2. The 13-3/8" casing is either welded or screwed on to the 13-3/8" × 13-5/8" landing base. The 18-5/8" conductor pipe is cemented at a distance ranging from a few inches to 2–3 feet below the landing base.

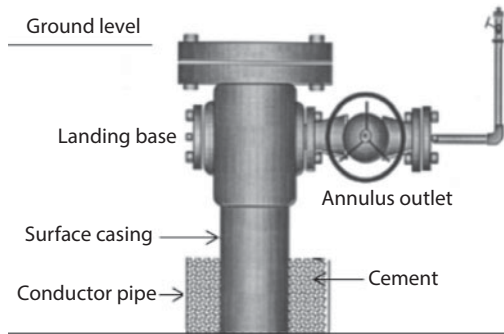

**Figure 2.2** Typical Landing Base and Surface Casing Set Up (modified from Farooqui, 1998).

**Procedure and Data:** A typical landing base inspection operation involves excavating the cellar to below the landing base to expose three to six feet of the surface casing or until hard cement is encountered below the landing base, whichever is earlier. The exposed section is sand blasted and then inspected for evidence of corrosion. The data from such inspections for the last six years (1991 through 1996) is presented in Table 2.1, while Figures 2.3–2.5 illustrate some cases of severe corrosion damage on the landing base and surface casing on oil as well as water wells.

**Causes:** The damage was occurring in spite of an apparently successful cathodic protection program that has reduced the number of casing leaks due to external corrosion damage. The possible causes of the corrosion damage were: leakage of water from surface piping and wellhead valves during various operations on water related wells, presence of highly saline and corrosive water close to surface in the area, and impediments to effective cathodic protection at shallow depths.

**Preliminary Solution:** In view of the safety and environmental hazards associated with possible shallow leaks from corroded casing or failure of wellhead equipment, a number of steps have been taken to control the damage. These include regular inspection and repairs at regular intervals, protection with field-applied corrosion resistant coatings, and a requirement to coat all new wells immediately after the rig release.

**Lessons learned:** Corrosion damage could jeopardize well safety to the below-grade wellhead equipment and the upper few feet of the surface casing. This was recognized as a potential problem and it could result in flow of well fluids outside the wellbore. An effective protection program

**Table 2.1** Well Inspection Data.

Well type	Well age (Years)				Total
	1-5	6-10	11-15	>15	
<b><i>Oil Wells</i></b>					
Inspected	72	72	71	311	526
Severe Corrosion	1	2	6	6	15
Percentage of Inspected	1	3	8	2	3
<b><i>Water Injection Wells</i></b>					
Inspected	34	34	73	103	244
Severe Corrosion	0	4	4	8	16
Percentage of Inspected	0	12	5	8	7
<b><i>Water Supply Wells</i></b>					
Inspected	9	24	20	27	80
Severe Corrosion	1	9	3	6	19
Percentage of Inspected	11	38	15	22	24
<b><i>Total Wells</i></b>					
Inspected	115	130	164	441	850
Severe Corrosion	2	15	13	20	50
% Of Inspected	2	12	8	5	6



**Figure 2.3** Damaged surface casing on an water injection well (Farooqui, 1998).



**Figure 2.4** Pitted surface casing of a oil well (Farooqui, 1998).



**Figure 2.5** Water leaking from a water supply well casing.

has been implemented that includes regular inspection, standardized repair procedures, and initial protection of all new wells with protective coatings as well as sacrificial anodes.

### *2.1.3.2 Communication*

There are no better issues in drilling process safety than communication. Communication in drilling begins before the first foot is drilled. It begins in the pre-planning and pre-spud meeting. Communication does not stop at the pre-spud meeting, rather continues throughout all the various meetings that are held. At the operator/contractor meeting, which should be private, operators need to review their respective responsibilities, the multimedia messaging service (MMS) requirements, the IADC report, the BOP drills (e.g., reaction and trip drills), land covenants and the BOP closing-in procedure. The pre-cement meeting is more of a people plan. The responsibilities of the company supervisor, drilling engineer, tool pusher, driller, feed pump operator, chief cementing engineer and mud engineer are all spelled out and delegated.

In addition to good communication at the various meetings, there also needs to be good communication between the crew and the home office. The

crew on-site needs to be very thoughtful and detailed in their reports of any problems. Their communication needs to include the trends and related facts, their operational plan to correct the problem and their recommendations.

Besides communication between the various parties, there is another type of communication which is extremely important in a drilling operation. The driller must learn to communicate with the bottom of the hole. He can do this through monitoring trends. The various trends tell the driller exactly what is happening down below and gives him the information that everyone needs to make critical decisions on a daily basis. In order to see these trends, they must be written down. Some of these trends that he must monitor include: i) pressure and stroke trends, ii) torque trends, iii) drag trends, iv) rate of penetration trends, v) mud trends, and vi) pit trends. The trends, daily reports, appraisals and other records are all effective tools in communication. The logging records help the geologists pick their sites and make better plans. The bit records help the drilling team in their future bit selection. The reports and records help the engineer do his post-appraisal of the well. It helps him to determine whether the program was followed or the deviations were necessary and how future programs can be improved during planning. Good communication helps management to properly supervise and optimize their operations.

Good drilling training programs do not merely give out information, they help drillers, engineers, rig foremen, and service companies learn to communicate with each other, optimize their drilling operations, and properly supervise the well. When Bill Murchison started Murchison Drilling Schools in 1977, he set out five objectives for his Operations Drilling Technology and Advanced Well Control Course. They were: i) how to supervise a drilling operation, ii) how to preplan field operations, iii) how to analyze and solve drilling problems, iv) how to prevent unscheduled events, and v) how to communicate on the rig. Twenty-four years later, the same five objectives are helping companies around the world to supervise, optimize, and communicate better on the rig. The training has proved so valuable that many oil companies, contractors, and service companies have made it standard policy to put all their new service men through the Murchison Drilling Schools Operations Drilling Technology and Advanced Well Control Course. It has become part of their overall training that they receive before going out into the field.

In order for effective communication to take place in that meeting, many issues must be considered. Here are just a few of those considerations:

1. The meeting must be well planned by the engineer (e.g., he must meet with a number of people before he even makes his plans).

2. The purpose of the meeting needs to be very clearly spelled out. Here are five purposes for that pre-spud meeting: i) to open all doors of communication, ii) to reduce unscheduled events, iii) to review the well plans, iv) to review the geological considerations, and finally v) to coordinate the responsibilities between the contractors, service companies and the operators. The meeting must have an agenda which helps accomplish these purposes.
3. The meeting needs to have the presence of the right people. The operator's superintendent and the contractor's superintendent both need to be there. The tool pushers and drillers, the foremen, the engineers, the geologist, the offshore installation manager and the representatives from the service companies all need to be at this meeting. Unless all these key individuals are at the meeting to both communicate their concerns with others and come to a mutual understanding of how the program is to be implemented, the efficiency, profitability and success of the entire drilling operation is jeopardized.

#### 2.1.3.3 *Personnel*

Given equal conditions during drilling/completion operations, personnel are the key to the success or failure of those operations. Overall well costs as a result of any drilling/completion problem can be extremely high. Therefore, continuing education and training for personnel directly or indirectly involved is essential to successful drilling/completion practices.

For example, four of every five major offshore accidents are caused by human errors. This highlights the need to make safety, which is the backbone of any offshore company's corporate culture. Over recent years, there has been a growing recognition of the importance of human factors in the management of safety-critical industries. Many of the concepts are new to the oil and gas industry with much of the seminal work and development of techniques having arisen from the nuclear and aviation domains. These have set the standard for human factors practice.

Human factors has identified the aetiology of most major incidents as being linked to human failure. The findings have been that, although most will have multiple causes, over 80% will have a cause which is related to human performance. Human factors is a relatively new science. It is concerned with adapting technology and the environment to the capacities and limitations of humans. The challenge for human factors is to act in a prescriptive way to make systems and working practices safer and more



efficient. Many drilling incidents have been found relating to human factors. However, currently there is not yet a special approach by which drilling safety professionals may rationally evaluate the actual human factor risk lever and accordingly select appropriate risk control measures for a given drilling process.

It has been found that more than 80% of incidents are related to human factors in the global drilling industry. After studying the human error features in 59 serious drilling blowout cases from 1970 to 2006 in China, it shows that the percentage of the human factor as direct cause of a blowout incident can reach 93.53%. It includes the individual violation and management deficiency which reveals the human factor.

Up to now, there is no special approach by which drilling safety professionals may rationally evaluate the actual human factor risk control and accordingly select appropriate risk control measures for a given drilling process. Therefore, it is necessary to create a special method for quantificational evaluation of the drilling human factor risks, so that strategically measures can be taken to control the risks associated with drilling activities.

Many accident investigation techniques and other methods used by the petroleum industry today list a set of underlying human-related causes and subsequent improvement suggestions. Norsok (2001) defines an accident as “an acute unwanted and unplanned event or chain of events resulting in loss of lives or injury to health, environment or financial values.” Another way of putting it is energy gone astray (Hovden *et al.*, 2012). What differentiates two accidents is primarily the type and amount of energy astray. The knowledge of accidents is important in order to operate with efficient risk management and preventative work. In order to increase the knowledge of accidents, they must be investigated. Accident investigation models aim to simplify complex events to something tangible and understandable.

#### **2.1.4 Stacked Tools**

Stacked tool is defined as “if a tool is lost or the drillstring breaks, the obstruction in the well is called junk or fish.” It cannot be drilled through if there is stacked tool. The preventive measure is to educate the crew. Special grabbing tools are used to retrieve the junk in a process called fishing. In extreme cases, explosives can be used to blow up the junk and then the pieces can be retrieved with a magnet.

Wellbore debris is responsible for many of the problems and much of the extra costs associated with producing wells, especially in extreme water depths and highly deviated holes. Even a small piece of debris at the right

place at the wrong time can jeopardize well production. For this reason, debris management has become a major concern for oil and gas producers. Considering rig rates and completion equipment costs, debris removal is moving into the realm of risk management.

A clean wellbore is not only a prerequisite for trouble-free well testing and completion. It also helps ensure optimum production for the life of the well. Debris left in the wellbore can ruin a complex, multimillion-dollar completion. It can prevent a completion from reaching total depth. It will never reach an optimum production level. These issues are pushing the industry to create reliable, efficient systems for quickly ridding of wellbores harmful debris and larger pieces of junk.

If a tool is lost or the drillstring breaks, the obstruction in the well is called junk or fish. It cannot be drilled through. Special gripping tools are used to retrieve the junk through a process called fishing. In extreme cases, explosives can be used to blow up the junk and then the pieces can be retrieved with a magnet.

During the stacked tool problem, the remedial measures are run the junk basket, run basket with collapsible teeth (e.g., “Poor Boy” Basket), and run magnet.

#### *2.1.4.1 Objects Dropped into the Well*

Despite utmost care, wrenches, nut-bolts, rocks or any objects (i.e., rather than fishing objects) are inadvertently dropped into the borehole while drilling. In addition, the LS-100 (The LS-100 is a small, portable mud rotary drilling machine manufactured by **Lone Star Bit Company** in Houston, Texas) is often operated near its design limits with a high degree of structural stress on the drill stems and tools. This will encounter unexpected layers of very soft sand or filter or hard rock. As a result, it can cause caving or tool breakage. Sometimes, the entire drillpipe can be lost in the hole.

If objects are dropped into the borehole after the final depth has been reached, it may be possible to leave them there and still complete the well. If this is not the case, it may be possible to make a “fishing” tool to set-up on the lost gear. For example, if a length of well screen falls down the borehole, it may be possible to send other sections down with a pointed tip on the end and “catch” the lost casing by cramming the pointed end forcefully into it. These types of “fishing” exercises require innovation and resourcefulness suitable to the circumstances. While this task may appear to be routine, there is no single “right” way of conducting this operation. If sediments have caved in on top of the drill bit or other tools, circulation should be resumed in the hole and the fishing tool placed over the lost equipment.

If the lost tools/bits/drillpipes are not critical, it is best to avoid retrieval efforts, instead, resorting to just changing the location somewhat and starting to drill a new hole. Even if the equipment is important, it is still best to start drilling at a new location while others try to retrieve it since considerable time can be spent on retrieval and there is a low likelihood of success. The decision to retrieve can be set aside while continuing the drilling operation.

#### 2.1.4.1.1 Case Study

An employee was operating a workbasket inside the substructure while doing various tasks in preparation to nipple down the annular. He had used a 5-pound (2.3 kg) shop hammer several minutes prior to the incident in order to break out the annular hydraulic lines. After he completed the task, he dropped the hammer to the bottom of the man-basket. While he was moving throughout the basket to arrange the BOP handler (chain hoist), the 5-pound (2.3 kg) hammer was accidentally “kicked” out of the basket. It was “launched” approximately 10 feet (3 meters) down to the driller’s side of the substructure where it struck another employee on the hard hat. The impact of the hammer created a pinch point between the hard hat and his safety glasses, thus resulting in a laceration below his left eyebrow.

**Cause of the incident:** i) The hammer was not secured or tethered after use, ii) employees were standing in the “line of fire” watching the employee in the work basket complete his work, iii) the employee operating the work basket did not call a “stop task” to move other employees out of the “danger area”, and iv) poor housekeeping procedures in the work basket (i.e., the hammer and other items were not placed or secured properly).

**Corrective Actions:** To address this incident, this company did the following: i) employees were reminded of the importance of tethering / securing any tools when working overhead, even when working in a work basket, ii) personnel were instructed to discuss “line of fire” for any work, especially when the potential for a dropped or “launched” object existed, iii) personnel were instructed to discuss application of Stop Work Authority (obligation) and were reminded that SWA includes stopping and asking other personnel / bystanders to move from a “danger area”, and iv) the JSA / Work Plan for operating in a work basket must be reviewed/ revised to include the importance of keeping the lift basket orderly (i.e., housekeeping must be maintained).

It is noted that this case study was taken from AIDC website for study purposes.

### 2.1.4.2 Fishing Operations

Fishing is the process of removing equipment that has become stuck or lost in the wellbore. Its name derives from a period in which a hook, similar to fishing hooks, used to be attached to a line before lowering into the borehole in order to extract the lost item. From that period onward, any object dropped or stuck in a well that interferes with its normal operations is called a fish and is targeted for removal from the well. The operation of removing these objects is called a “fishing job”. Typically, in drilling vocabulary, a fishing job is simply called ‘fishing.’ The fish, or lost object, is classified as tubular (e.g., drillpipe, drill collars, tubing, casing, logging tools, test tools, and tubing) or miscellaneous (e.g., bit cones, small tools, wire line, chain, hand tools, tong parts, slip segments, and junk). Industry-wide, 25% of drilling costs may be attributed to fishing. Fishing jobs are classified into three categories: i) open hole fishing: when there is no casing in the area of fishing, ii) cased hole fishing: when the fish is inside the casing, and iii) thru-tubing: when it is necessary to fish through the restriction of a smaller pipe size (tubing). Figure 2.6 shows the basic fishing tools including the spear and socket, each with milled edges. Using nails and wax, an impression block helps determine what is stuck downhole. Anything that goes in the hole can be left there and anything with an outside diameter less than that of the hole can be dropped in it. After a fishing job begins, any and/or

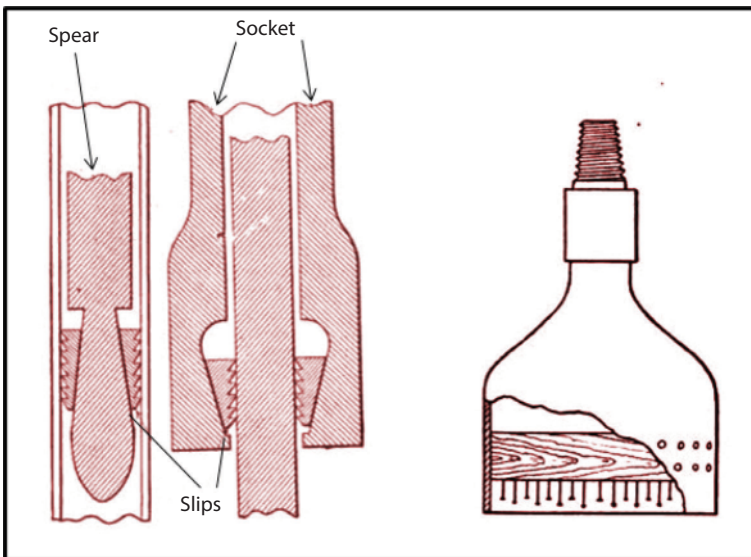

Figure 2.6 Basic fishing tools.

all fishing tools in the hole may themselves have to be removed by fishing. So precautions should be taken.

The most causes of fishing jobs are i) twist-off, ii) sticking of the drill-string, iii) bit and tool failures, and iv) foreign objects such as hand tools, logging instruments, and broken wire line or cable lost in the hole. When the preparation for a fishing job becomes necessary in an uncased hole, one has to find out as much as possible about the situation before taking action. In addition, the questions that need to be answered before fishing operation are: i) what is to be fished out of the hole?, ii) is the fish stuck, or is it resting freely?, iii) if stuck, what is causing it to be stuck?, iv) what is the condition in the hole?, v) what are the size and condition of the fish?, vi) could fishing tools be run inside or outside the fish?, vii) could other tools be run through the fishing assembly that is to be used?, viii) are there at least two ways to get loose from the fish if it cannot be freed?

Any fishing operation in an open or cased hole involves the usage and operation of the following tools and accessories: i) spears and overshoots, ii) internal and external cutters, iii) milling tools, iv) taps and die collars, v) washover pipe – a) washover pipe overshot (releasable), b) washover pipe back-off connector, and c) washover pipe drill collar spear, vi) accessories – a) bumper jar, b) mechanical jar, c) hydraulic jar, d) jar accelerator, e) hydraulic pull tool, and f) reversing tool, vii) safety joints, viii) junk retrievers, ix) impression blocks. In a fishing job involving the drillstring, the operator can often ascertain whether or not the lost drillpipe is stuck in the hole by determining what happened just before it was lost. The stuck pipe problems will be discussed in Chapter 7.

**History of the Fishing:** During early years of petroleum well drilling, spring-pole cable tools were used instead of rotary drilling. Drillers used a hook connected by hemp rope to the pole in order to recover drilling tools inadvertently left in the wellbore. The physical and operational similarity to the angler's art resulted in the process of lost tool recovery being named "fishing" (Moore 1955). The Prud'homme family plantation near Bermuda, Louisiana, displays in its museum a set of rotary drilling equipment, including fishing tools, used to dig three water wells in 1823. A French engineer designed this equipment, and an African technician built it (Brantly, 1961). Both rotation and reciprocation were powered by a fifteen-man prime mover. Most fishing tools were designed for cable-tool drilling and for production operations, then adapted for rotary drilling. Fishing tools have been necessary ever since commercial drilling operations were started. It is generally accepted that fishing operations account for 25% of drilling costs worldwide (Short, 1995). Since fishing is a non-routine procedure,

all personnel connected with a given operation are more likely to commit operational error. Study on fishing art is needed which can be beneficial for engineering, geological, operational, and accounting staff.

**Conventional Fishing:** In oil-field operations, *fishing* is the technique of removing lost or stuck objects from the wellbore. The term *fishing* is taken from the early days of cable-tool drilling. At that time, when a wireline would break, a crew member put a hook on a line and attempted to catch the wireline to retrieve, or “fish for,” the tool. Necessity and ingenuity led these oil-field fishers to develop new attraction. The trial-and-error methods of industry’s early days built the foundation for many of the catch tools used currently. A fish can be any number of things, including: (i) stuck pipe, (ii) broken pipe, (iii) drill collars, (iv) bits, (v) bit cones, (vi) dropped hand tools, (vii) sanded-up or mud-stuck pipe, (viii) stuck packers, or (ix) other junk in the hole. There are some conventional fishing jobs such as: (i) wash overs, (ii) overshot runs, (iii) spear runs, (iv) wireline fishing, (v) stripping jobs, and (vi) jar runs which are among many fishing techniques developed to deal with the different varieties of fish.

Some care should be taken when an object is pulled out of the hole with most tools and fishing so it does not create a swelling action. Care should also be taken to prevent pulling into a tight place such as a key seat so you cannot go back down. Fishing jobs are very much a part of the planning process in drilling and workover operations. Drill operators will often budget for fishing with the increasing cost of rig time and depth, and due to more complicated wells. When a fishing operation is planned for a workover, the operator will work closely with a fishing-tool company to design a procedure and develop a cost estimate. Taking into account the probability of success, the cost of a fishing job has to be less than the cost of re-drilling or sidetracking the well for it to make economic sense.

Figure 2.7 shows the bit components such as bit cones, nozzles, and other pieces of junk which are typically small enough to be retrieved by a magnet (Figure 2.8) or junk basket (Figure 2.9). The most common fish is bit cones. Cones are run off for several reasons: i) poor solids control, ii) poor hydraulics, iii) improper bit choice, iv) operator error such as dropping or pinching, v) manufacturing defects, vi) excessive time on bottom, vii) inordinately abrasive lithology, and viii) unsuspected junk on bottom. Magnet is used to retrieve small pieces of ferrous material from the hole. Some junk magnets have circulating ports that enable cuttings to be washed away from the junk. In general, circulation of drilling fluid lifts the junk off-bottom. Beneath the tool joint, mud velocity decreases as the annulus grows wider. This decrease in mud velocity allows the junk to



**Figure 2.7** Bit components.



**Figure 2.8** Junk magnet.

settle into the basket opening which is brought by running the boot basket (Figure 2.9).

Proper attention can prevent all of these situations except for manufacturing defects and abrasive lithology. The hole must be uncovered in order for hand tools to be lost down it. This can most easily happen when nipping up, followed by the time when a complex bottom hole assembly passes through the rotary table during tripping. At this time, the rotating head packing if present must be removed. Some reamers and stabilizers will not even pass through a common stripping rubber. Loose tong and slip dies should have been repaired prior to tripping and especial care should be taken with hand tools during this period. Drilling ahead with an old stripping rubber on top of the flow nipple can help prevent this type of loss during connections.

Drill collars are lost through i) worn and poorly shopped boxes and pins, ii) over and under make-up torque, iii) harmonic stresses, and iv) failure to

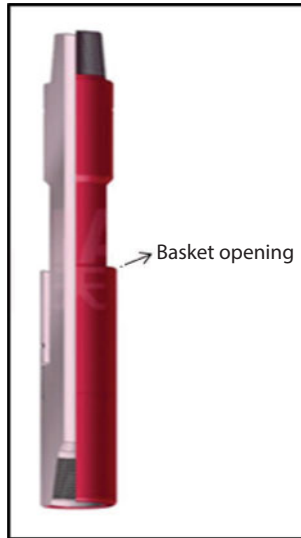

Figure 2.9 Boot basket.

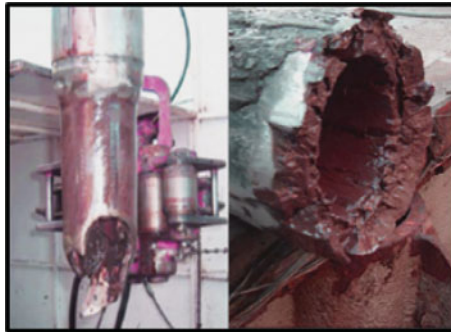
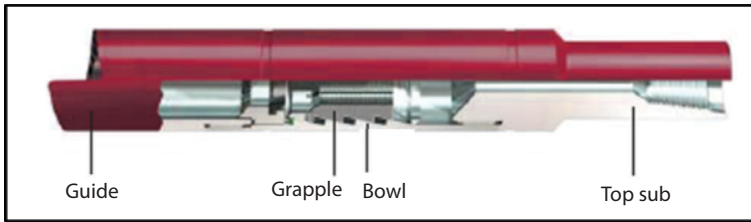

Figure 2.10 Drillstring failure (Perforated drill collar).

use a wedding band (collar clamp). Make-up torque failures can be avoided by the use of a gauge. Wear can be found by inspection, collar clamp loss stopped by adequate supervision, and harmonic stress can be minimized by proper rotary speed. Poor shopping is a matter that is harder to deal with, and it seems to be on the increase. As shown in Figure 2.10, excessive torque can cause a drillstring to part downhole. Here (left), the drillpipe has twisted off beneath the tool joint. Even thick-walled drill collars may be subjected to wear and fatigue.

Figure 2.11 shows the overshot assembly, which is divided into three segments. The top sub connects the overshot to workstring. The bowl has





**Figure 2.11** Overshot.

a tapered helical design to accommodate a grapple, which holds the fish in place. The guide helps position the overshot onto the fish.

**Fishing for Bit Cones, Tong Dies, and Small Tools:** When the bit is on the bank and the small junk is in the hole, several choices present themselves. If the hole is mudded up and a fishing magnet is immediately available, go directly back to bottom and try to catch the fish. If not mudded up, or if a magnet is not on location, run a used bit below two junk subs and attempt to bust and wash by the junk. If no hole can be made, mud up and call for a junk basket. When it arrives or mud up is complete, round trip placing the junk basket on bottom. Cut hole equivalent to the length of the junk basket and withdraw from the hole. The junk basket is similar to a core barrel and will retain the fish and core by means of retainer springs. If the fish is recovered, drill ahead. If not, run a used bit and attempt to drill and wash by them. If no hole can be made, mill the junk with a concave mill. The concavity will center the cones or tools and bust them up. The two junk subs should remain in the string until the iron has been accounted for. Especial care should be taken to remove all metal junk from the hole before a diamond or P.D.C. bit is run.

**Milling:** Besides the dressing of fish tops, mills are used to grind up junk (Figure 2.12). They are also used to cut casing windows, to ream out casing, to cut fishing necks, and to mill up tubulars that cannot be fished (e.g., drillpipe cemented in the hole). Clustered tungsten carbide such as Klustrite is used to face mills. Larger particles are used for milling larger objects. Too much weight will knock the larger particles off the mill face. High speed and high weight certainly do not invariably yield high rate of penetration. One or two magnets should be used in the possum belly and cleaned continuously while milling. Cuttings are known to build up in the stack, which should be inspected and cleaned as needed.

**Fishing Equation:** The decision to fish or not must be weighed against a need to preserve the wellbore, recover costly equipment or

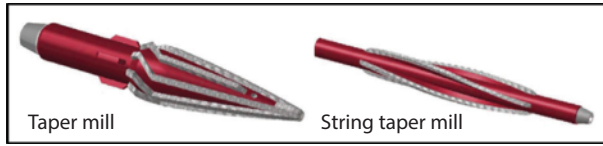

**Figure 2.12** Lead mill (left) and string mill (right).

comply with regulations. Each choice is fraught with its own costs, risks and repercussions. Before committing to a specific course of action, the operator must consider a number of factors: i) well parameters: proposed total depth, current depth, depth to top of the fish and daily rig operating costs, ii) Lost-in-hole costs: the value of the fish minus the cost of any components covered by tool insurance, iii) fishing costs: daily fee for fishing expertise and daily rental charges for fishing tools and jars, and iv) fishing timetable: time spent mobilizing fishing tools and personnel, estimated duration of the fishing job and the probability of success.

Earlier research has derived equations to determine how long fishing operations can be economically justified. These were based on Gulf of Mexico wells. The work presented here investigates the economics of fishing in the North Sea. The effort was justified by an early BP task force review, which showed that the Gulf of Mexico and the North Sea have significantly different sticking problems. In the Gulf of Mexico, most stuck pipe is due to differential sticking. Spotting a diesel based pill is considered to be the most successful remedy. In the North Sea, mechanical sticking is the major problem and the best remedial action is less obvious. Spotting a pill is only one option among a number of possible options. In 1984, Keller *et al.* (1984) introduced the concept of Economic Fishing Time (*EFT*). They developed an equation to calculate the time at which the cost of fishing becomes equal to the cost of an immediate side-track. They considered that probability of successful fishing can be estimated as:

$$EFT = \frac{P_s KHC}{DFC} \quad (2.1)$$

where:

- EFT* = Economic fishing time in days.
- $P_s$  = Probability of successful fishing.
- KHC* = Known hole costs (Value of fish + cost to re-drill to original depth).
- DFC* = Daily fishing cost.

The fishing times an *EFT* were characterized using the Weibull distribution which has the following probability density function (PDF)

$$f(t) = m\lambda t^{m-1} e^{-\lambda t^m} dt \tag{2.2}$$

where

- $t$  = Time in hours
- $\lambda$  = Weibull scale parameter
- $m$  = Weibull shape parameter

The probability of freeing the pipe before time  $t$  is given by the cumulative distribution function (CDF):

$$f(t) = 1 - e^{-\lambda t^m} \tag{2.3}$$

where  $f(t)$  is the time dependent probability of freeing stuck pipe. Using  $f(t)$  instead of a fixed probability and setting  $t = EFT$ , Eq. (2.1) may be rewritten as:

$$EFT = \frac{F(EFT)KHC}{H} \tag{2.4}$$

where

- $EFT$  = Economic fishing time
- $H$  = Hourly fishing cost

This may be rearranged to give:

$$\frac{F(EFT)}{EFT} = \frac{H}{KHC} \tag{2.5}$$

This ratio will be referred to as the cost ratio.

**Economic Considerations:** There is an important trade-off that must be considered during any fishing operation. Although the actual cost of a fishing operation is normally small compared to the cost of the drilling rig and other investments in support of the overall drilling operation, if a fish or junk cannot be removed from the borehole in a timely fashion, it may be necessary to sidetrack (i.e., directionally drill around the obstruction) or drill another borehole. Thus, the economics of the fishing

operation and the other incurred costs at the well site must be carefully and continuously assessed while the fishing operation is underway. It is very important to know when to terminate the fishing operation and get on with the primary objective of drilling a well. In such case, Eq. (2.1) can be rewritten in terms of number of days ( $D_f$ ) that should be allowed for fishing operation as:

$$D_f = \frac{V_f + C_s}{R_f + C_d} \quad (2.6)$$

where

- $V_f$  = the replacement value of the fish, \$
- $C_s$  = estimated cost of the sidetrack or the cost of restarting the well, \$
- $R_f$  = the cost per day of the fishing tool and services, \$/day
- $C_d$  = the cost per day of the drilling rig (and appropriate support), \$/day

**Optimum Fishing Time (OFT):** *OFT* is an economically attractive alternative to *EFT* because it attempts to minimize total costs. When fishing operations are started, there are only two possible outcomes: getting free or failing to free. The costs associated with these outcomes are:

$$\text{Cost}_{free} = Ht \quad (2.7)$$

$$\text{Cost}_{fail} = Ht + KHC \quad (2.8)$$

The probability of getting free is given by Eq. (2.3). The expected cost (*EC*) of a stuck pipe incident is therefore:

$$EC = Ht F(t) + \{1 - F(t)\} \times \{KHC + (H \times t)\} \quad (2.9)$$

Eq. (2.9) can be simplified to:

$$EC = Ht + KHC - KHC F(t) \quad (2.10)$$

The gradient equation is given by:

$$\text{Gradient} = F(t)KHC - H \quad (2.11)$$

OFT is the point at which the gradient becomes zero which can be derived from Eq. (2.11) as:

$$f(OFT) = \frac{H}{KHC} \tag{2.12}$$

Assuming that the hourly rate for Remedial Operation Time (ROT) is similar to that for fishing, so, Eqs. (2.5) and (2.12) may be rewritten as follows:

$$\frac{F(EFT)}{EFT} = \frac{1.43 H}{KHC} \tag{2.13}$$

$$f(OFT) = \frac{1.43 H}{KHC} \tag{2.14}$$

In such case, the calculation for Cost Ratio must be:

$$Cost\ Ratio = \frac{1.43 H}{KHC} \tag{2.15}$$

If ROT is not considered, the recommended fishing time will be longer than the true OFT. All the necessary information is now available to complete the new fishing equation. By substituting the terms in Eq. (2.15), the equation becomes:

$$Cost\ Ratio = \frac{1.43 H}{V + 56H + 9D + \frac{7HD}{1250} + 13,000 + RH} \tag{2.16}$$

where

- $v$  = Value of drillstring below stuck point (US\$)
- $D$  = Estimated depth of stuck point (meters)
- $H$  = Hourly rig operating rate (US\$)
- $R$  = Time taken to drill original hole below stuck point (hours)

#### 2.1.4.2.1 Case Study

During drilling of a 7 7/8-in. hole, a joint of 6 1/8-in. drill collar twisted off, leaving behind a parted drill collar and the BHA. While pulling out of the hole, the operator called fishing services to retrieve the remaining

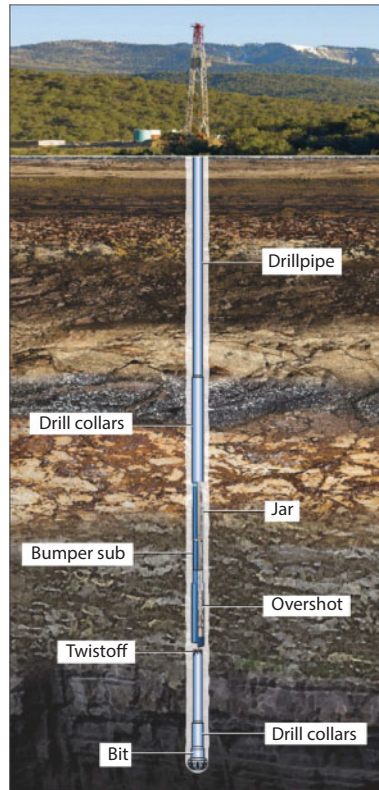

**Figure 2.13** Fishing BHA.

drillstring from the hole. The fishing expert made up a fishing string consisting of drillpipe, drill collars, a jar, a bumper sub and an overshot (Figure 2.13). The driller ran the fishing string in the hole and succeeded in reaching the top of the fish. After the overshot engaged the twisted off collar, the fisherman noted an increase in weight as the driller slowly pulled on the fishing string. Once the fishing specialist was assured that the overshot had latched onto the fish, the driller tripped out of the hole and laid down the fish for examination on the pipe rack. Hence, the operator attributed the problem to pipe fatigue.

**Personal Experience:** In order to perform fishing on a well, drilling must be stopped and special fishing tools should be employed. Most fishing tools are screwed at the end of a fishing string, similar to drillpipe, and lowered into the well. There are two options to recover lost pipe: i) the first is a spear, which fits within the pipe and then grips the pipe from the inside,

and ii) an overshoot may be employed, and this tool surrounds the pipe and grips it from the outside to carry it up to the surface. When a fish is difficult to grip, a washover pipe or washpipe is used. Washpipe is run into the well and then the cutting edge grinds the fish to a smooth surface. Then drilling fluids are pumped into the well to remove debris, and another tool is used to retrieve the remaining fish.

Sometimes, a junk mill and boot basket are used to retrieve fish from the wellbore. In this instance, a junk mill is lowered into the well and rotate to grind the fish into smaller pieces. A boot basket which is also known as a junk basket is then lowered into the well. Drilling fluid is pumped into the well, and the ground parts of the fish are raised into the basket and then to the surface by the boot basket. In order to recover casing which has collapsed within the well or irregularly shaped fish, a tapered mill reamer can be used. Permanent magnets are employed to reclaim magnetic fish, and a wireline spear uses hooks and barb to clasp broken wireline. In addition, an explosive might be detonated within the well to break the fish up into smaller pieces, and then a tool such as a junk bucket is used to retrieve the smaller items.

When a fishing professional is unable to determine which fishing tool might work best to retrieve the fish, an impression block is used to get an impression of the fish and allow the professional to know exactly what he or she is dealing with. Fishing a well may take days to complete, and during this time, drilling cannot be continued. However, the operator is still responsible for drilling fees. Some drilling contractors offer fishing insurance, making operators not responsible for rig fees during fishing operations.

#### *2.1.4.3 Junk Retrieve Operations*

Junk is usually described as small items of non-drillable metals that fall or are left behind in the borehole during the drilling, completion, or work-over operations (Figure 2.14). These non-drillable items must be retrieved before operations can be continued. It is noted that junk retrieving operations may be recognized as part of a fishing operation too. It is important to remove the fish or junk from the well as quickly as possible. The longer these items remain in a borehole, the more difficult these parts will be to retrieve. Further, if the fish or junk is in an open hole section of a well the more problems there will be with borehole stability.

Junk in the hole such as metal fragments or broken-off or dropped equipment, may lodge between the hole wall and drillpipe, tool joints, or drill collars (Figure 2.14). Except when the drillstring pulls around the object or the object can be pushed into the hole wall, serious fishing problems can

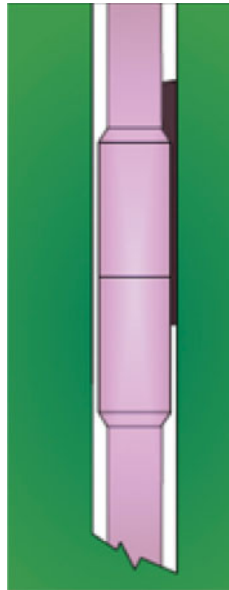

**Figure 2.14** Junk retrieve operations.

develop. This is especially true if the drillpipe gets jammed to one side in a cased hole. To avoid junk, never leave the hole unprotected or leave loose objects lying around the rotary area. Junk in the hole, smaller fish, lost in the hole may include i) bit cones, bearings, or other parts lost when a bit breaks, ii) broken reamer or stabilizer parts, iii) metal fragments lost in a twist-off, iv) metal fragments produced by milling the top of a fish to aid in its retrieval, v) naturally occurring pieces of hard, crystalline, or abrasive minerals such as iron pyrite, vi) tong pins, wrenches, or other items that fall into the hole because of rig equipment failure or by accident, vii) equipment such as packer, core barrels, and drill stem test (DST) tools that become lodged downhole, and viii) wire line tools and parted wire line.

#### 2.1.4.4 *Twist-off*

Twist-off is a parting of the drillstring caused by metal fatigue or washout (Figure 2.15). If the drillpipe twists off, this means that the pipe was twisted along its vertical axis. As a result, the fluid cycle will stop leading to expose the bit into heat (i.e., no cooling + no lubrication). Twist-off will also eliminate the nozzles fluid pressure which supports the drilling operation. It can lead to a drillpipe fatigue failure (Figure 2.16). This typically happens when lower sections of the pipe get stuck. There are early symptoms of twist-off



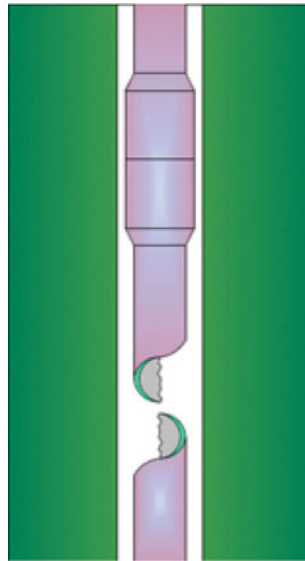

Figure 2.15 Pipe twist-off.

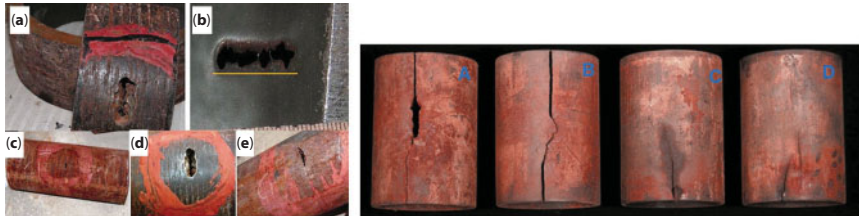

Figure 2.16 Pipe failure due to twist-off and/or fatigue.

such as the torque indication. The higher the torque deflection during drilling operation, the more it is likely to get twist-off. Therefore, the driller should be aware of the situation.

Twist-off is usually the result of not moving the whole pipe in the same rotation speed. It is also the result of: i) rough pipe handling, ii) faulty drill-string, iii) stress reversals in a sharply deviated hole drilling with drillpipe in compression, iv) poorly stabilized drill collars scarring by tong dies, v) improper makeup torque, vi) erosion caused by washout, vii) other damage that creates weak spots where cracks can form and enlarge under the constant bending and torque stresses of routine drilling, and viii) other damage that creates weak spots where cracks can form and enlarge under the constant. The pipe often separates in a helical break or in a long tear

or split. The surface signs of a twist-off include i) loss of drillstring weight, ii) lack of penetration, iii) reduced pump pressure, iv) increased pump speed, v) reduced drilling torque, and vi) increased rotary speed.

### 2.1.5 Difficult-to-drill Rocks

In general, it is difficult to drill rocks especially if it is hard rock. Problems related to drilling hard rock are very frustrating. Interpretation of pore pressure for hard rock is mysterious. However, it is assumed that pore pressures are close to “normal” over long depth intervals because drilling in hard rock is slow and there is no kick (i.e., in overpressured shale sections). As a result, many hard rock drilling problems cannot be logically explained. For overbalance drilling, hard rock drilling problems are: (i) slow drilling rate; (ii) lost circulation; (iii) differential sticking; (iv) stress-corrosion fatigue – twisted-off drillpipe, lost bit cone, drillstring wash-outs; (v) poor directional control; (vi) severe dog legs; (vii) deep invasion – poor log evaluation, irreparable formation damage. For underbalance drilling, hard rock drilling problems are: (i) sloughing shale – bridges and fill (i.e., lost time kicks); (ii) corrosive gas entrainment – drillpipe and bit embrittlement; (iii) borehole enlargement – difficult fishing jobs, poor cement displacement, and casing collapse (no cement sheath); (iv) plastic flow (i.e., shale or salts) – excessive torque, lost circulation beneath pack-off, and stuck pipe. Hard rocks are difficult to drill because of the extreme zig-zags from overpressured shales to sub-normally pressured sands and carbonates.

A better understanding of the presence and magnitude of the pressure shifts may help us minimize the worst extremes of imbalance and more intelligently strike an optimum compromise, realizing that mud density and, especially, mud chemistry can never completely solve these hard rock drilling problems. Well log pressure plots in these erratic stratigraphies are so difficult to interpret that they often have been considered useless. A significant challenge for oil and gas operating companies worldwide is to maximize drill bit run intervals within interbedded, hard-to-drill rock sections. In these more challenging applications, polycrystalline diamond compact (PDC) and roller cone insert designs are pushed to their limits and often fail due to PDC thermal fatigue, severe abrasion, bearing failures, or impact damage. This translates into additional trips for replacing bit types or cleaning the hole from junk left in the hole, representing significant added costs.

### 2.1.6 Resistant Beds Encountered

Once a resistant bed is encountered resulting in dramatic drop of penetration rate, a decision needs to be made whether to stop drilling or to

continue. If the resistant bed is comprised of gravels, the drilling fluid may need to be thickened to lift-out the cuttings. If the resistant bed is hard granite, drilling with the LS-100 should cease. Other drilling methods should be found or drilling should be attempted at another location.

### 2.1.7 Slow Drilling

Slow drilling refers to the rate of penetration (ROP) which is not in a desired level. ROP is defined as the speed at which the drill bit can break the rock under it and thus deepen the wellbore. This speed is usually reported in units of feet per hour (ft/hr) or meters per hour (Schlumberger glossary). ROP is one of the indicators and operational parameters for evaluating drilling performance. Slow drilling is the result of this performance. In addition, drilling efficiency will have the desired effects on costs when all critical operational parameters are identified and analyzed. These parameters are referred to as performance qualifiers (PQs). PQs include footage drilled per bottomhole assembly (BHA), downhole tool life, vibrations control, durability, steering efficiency, directional responsiveness, ROP, borehole quality, etc.

Most of the factors that affect ROP have influencing effects on other PQs. These factors can be grouped into three categories: i) planning, ii) environment, and iii) execution. The planning group includes hole size, well profile, casing depths, drive mechanism, bits, BHA, drilling fluid (i.e., type, and rheological properties), flow rate, hydraulic horsepower, and hole cleaning, etc. In environmental, factors such as lithology types, formation drillability (i.e., hardness, abrasiveness, etc.), pressure conditions (i.e., differential, and hydrostatic) and deviation tendencies are included. Weight on bit (WOB), RPM and drilling dynamics belong to the execution category. ROP can be categorized into two main types: i) instantaneous, and ii) average. Instantaneous ROP is measured over a finite time or distance, while drilling is still in progress. It gives a snapshot perspective of how a particular formation is being drilled or how the drilling system is functioning under specific operational conditions. Average ROP is measured over the total interval drilled by a respective BHA from trip-in-hole (TIH) to pull-out-of-hole (POOH).

It has long been known that drilling fluid properties can dramatically impact drilling rate. This fact was established early in the drilling literature, and confirmed by numerous laboratory studies. Several early studies focused directly on mud properties, clearly demonstrating the effect of kinematic viscosity at bit conditions on drilling rate. In laboratory conditions, penetration rates can be affected by as much as a factor of three by

altering fluid viscosity. It can be concluded from the early literature that drilling rate is not directly dependent on the type or amount of solids in the fluid, but on the impact of those solids on fluid properties, particularly on the viscosity of the fluid as it flows through bit nozzles. This conclusion indicates that ROP should be directly correlated to fluid properties which reflect the viscosity of the fluid at bit shear rate conditions, such as the plastic viscosity. Secondary fluid properties reflecting solids content in the fluid should also provide a means of correlating to rate of penetration, as the solids will impact the viscosity of the fluid.

### 2.1.7.1 Factors Affecting Rate of Penetration

Factors that affect the ROP are numerous and perhaps important variables. These variables are not recognized well up to-date. A rigorous analysis of ROP is complicated by the difficulty of completely isolating the variables under study. For example, the interpretation of field data may involve uncertainties due to the possibility of undetected changes in rock properties. Studies of drilling fluid effects are always plagued by difficulty of preparing two muds having all properties identical except one which is under observation. While it is generally desirable to increase penetration rate, such gains must not be made at the expense of overcompensating detrimental effects. The fastest ROP does not necessarily result in the lowest cost per foot of drilled hole. Other factors such as accelerated bit wear, equipment failure, etc., may raise the cost.

The factors that have an effect on ROP are listed under two general classifications such as environmental and controllable. Table 2.2 shows the list of parameters based on these two categories. Environmental factors

**Table 2.2** Variables that affect ROP.

<b>Environmental factors</b>	<b>Controllable factors (alterable)</b>
Depth	Bit Wear State
Formation properties	Bit design
Mud type	Weight on bit
Mud density	Rotary speed
Other mud properties	Flow rate
Overbalance mud pressure	Bit hydraulic
Bottom-hole mud pressure	Bit nozzle size
Bit size	Motor/turbine geometry

such as formation properties and drilling fluids requirements are not controllable. Controllable factors such as weight on bit, rotary speed, and bit hydraulics on the other hand are the factors that can be instantly changed. Drilling fluid is considered to be an environmental factor because a certain amount of density is required in order to obtain a specific objective to have enough overpressure so that it can avoid flow of formation fluids. Another important factor is the effect of overall hydraulics to the whole drilling operation. This operation is influenced by many factors such as lithology, type of the bit, downhole pressure and temperature conditions, drilling parameters and mainly the rheological properties of the drilling fluid. ROP performance is a function of the controllable and environmental factors. It has been observed that ROP generally increases with decreased equivalent circulating density (ECD).

Another important term controlling the ROP is the cuttings transport. Ozbayoglu *et al.* (2004) conducted extensive sensitivity analysis on cuttings transport for the effects of major drilling parameters, while drilling for horizontal and highly inclined wells. It was concluded that the average annular fluid velocity is the dominating parameter on cuttings transport, the higher the flow rate the lesser the cuttings bed development. ROP and wellbore inclinations beyond 70° did not have any effect on the thickness of the cuttings bed development. Drilling fluid density have moderate effects on cuttings bed development with a reduction in bed removal with increased viscosities. Increased eccentricity positively affected cuttings bed removal. The smaller the cuttings the more difficult it is to remove the cuttings bed. It is clear that turbulent flow is better for bed development prevention. However, in any engineering study of rotary drilling it is convenient to divide the factors that affect the ROP into the following list: i) personal efficiency; ii) rig efficiency; iii) formation characteristics (e.g., strength, hardness and/or abrasiveness, state of underground formations stress, elasticity, stickiness or balling tendency, fluid content and interstitial pressure, porosity and permeability etc.); iv) mechanical factors (e.g., bit operating conditions – a) bit type, and b) rotary speed, and c) weight on bit); v) hydraulic factor (e.g., jet velocity, bottom-hole cleaning); vi) drilling fluid properties (e.g., mud weight, viscosity, filtrate loss and solid content); and vii) bit tooth wear, and depth. However, for horizontal and inclined well bores, hole cleaning is also a major factor influencing the ROP. The basic interactive effects between these variables were determined by design experiments. Variable interaction exists when the simultaneous increase of two or more variables does not produce an additive effect as compared with the individual effects. The rate of penetration achieved with the bit as well as the rate of bit wear, has an obvious and direct bearing on

the cost per foot drilled. The most important variables that affect the ROP are: i) bit type, ii) formation characteristics, iii) bit operating conditions (i.e., bit type, bit weight, and rotary speed), iv) bit hydraulics, v) drilling fluid properties, and vi) bit tooth wear.

**1. Personal Efficiency:** The manpower skills, and experiences are referred to as personal efficiency. Given equal conditions during drilling/completion operations, personnel are the key to the success or failure of those operations and ROP is one of them. Overall well costs as a result of any drilling/completion problem can be extremely high. Therefore, continuing education and training for personnel is essential to have a successful ROP and drilling/completion practices.

**2. Rig Efficiency:** The integrity of drilling rig and its equipment, and maintenance are major factors in ROP and to minimizing drilling problems. Proper rig hydraulics (e.g., pump power) for efficient bottom and annular hole cleaning, proper hoisting power for efficient tripping out, proper derrick design loads, drilling line tension load to allow safe overpull in case of a sticking problem, and well-control systems (e.g., ram preventers, annular preventers, internal preventers) that allow kick control under any kick situation are all necessary for reducing drilling problems and optimization of ROP. Proper monitoring and recording systems that monitor trend changes in all drilling parameters are very important to rig efficiency. These systems can retrieve drilling data at a later date. Proper tubular hardware specifically suited to accommodate all anticipated drilling conditions, and effective mud-handling and maintenance equipment will ensure that the mud properties are designed for their intended functions.

**3. Formation Characteristics:** The formation characteristics are some of the most important parameters that influence the ROP. The following formation characteristics affect the ROP: i) elasticity i.e., elastic limit, ii) ultimate strength, iii) hardness and/or abrasiveness, iv) state of underground formations stress, v) stickiness or balling tendency, vi) fluid content and interstitial pressure, and vii) porosity and permeability. Among these parameters, the most important formation characteristics that affect the ROP are the elastic limit and ultimate strength of the formation. The shear strength predicted by the Mohr failure criteria sometimes is used to characterize the strength of the formation.

The elastic limit and ultimate strength of the formation are the most important formation properties affecting penetration rate. It is mentioned that the crater volume produced beneath a single tooth is inversely

proportional to both the compressive strength of the rock and the shear strength of the rock. The permeability of the formation also has a significant effect on the penetration rate. In permeable rocks, the drilling fluid filtrate can move into the rock ahead of the bit and equalize the pressure differential acting on the chips formed beneath each tooth. It can also be argued that the nature of the fluid contained in the pore space of the rock also affects this mechanism since more filtrate volume would be required to equalize the pressure in a rock containing gas than in a rock containing liquid. The mineral composition of the rock also has some effect on penetration rate.

To determine the shear strength from a single compression test, an average angle of internal friction varies from about 30 to 40° from the most rock. The following model has been used for a standard compression test:

$$\tau_0 = \frac{\sigma_1}{2} \cos \theta \tag{2.17}$$

where,

- $\tau_0$  = shear stress at failure, psi
- $\sigma_1$  = compressive stress, psi
- $\theta$  = angle of internal friction

The threshold force or bit weight  $(W/d)_t$  required to initiate drilling was obtained by plotting drilling rate as a function of bit weight per bit diameter and then extrapolating back to a zero drilling rate. The laboratory correlation obtained in this manner is shown in Figure 2.17.

The other factors such as permeability of the formation have a significant effect on the ROP. In permeable rocks, the drilling fluid filtrate can move into the rock ahead of the bit and equalize the pressure differential acting on the chips formed beneath each tooth. Formation as nearly an independent or uncontrollable variable is influenced to a certain extent by hydrostatic pressure. Laboratory experiments indicate that in some formations increased hydrostatic pressure increases the formation hardness or reduces its drill-ability. The mineral composition of the rock also has some effect on ROP. Rocks containing hard, abrasive minerals can cause rapid dulling of the bit teeth. Rocks containing gummy clay minerals can cause the bit to ball up and drill in a very inefficient manner.

**4. Mechanical Factors:** The mechanical factors are also sometimes described as bit operating conditions. The following mechanical factors affect the ROP: i) bit type, ii) rotary speed, and iii) weight on bit.

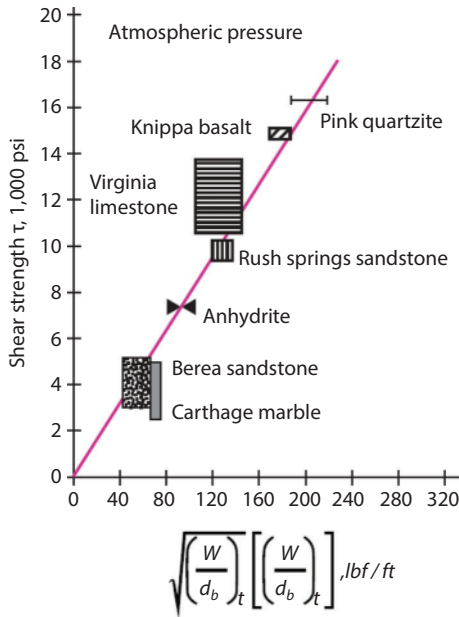
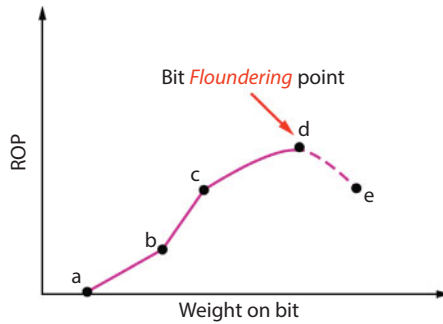

**Figure 2.17** Relationship between rock shear strength and threshold bit weight at atmospheric pressure (Hossain and Al-Majed, 2015).

**i) Bit Type:** The bit type selection has a significant effect on rate of penetration. For rolling cutter bits, the initial penetration rates for shallow depths are often highest when using bits with long teeth and a large cone off set angle. However, these bits are practical only in soft formations because of rapid tooth wear and sudden decline in penetration rate in harder formations. The lowest cost per foot drilled usually is obtained when using the longest tooth bit that will give a tooth life consistent with the bearing life at optimum bit operating conditions. The diamond and PDC bits are designed for a given penetration per revolution by the selection of the size and number of diamonds or PDC blanks. The width and number of cutters can be used to compute the effective number of blades. The length of the cutters projecting from the face of the bit (less the bottom clearance) can limit the depth of the cut. The PDC bits perform best in soft, firm, and medium-hard, nonabrasive formations that are not gummy. Therefore, the bit type selection must be considered, i.e., whether a drag bit, diamond bit, or roller cutter bit must be used, and the various tooth structures affect to some extent the drilling rate obtainable in a given formation.

Figure 2.18 shows the characteristic shape of a typical plot of ROP vs. WOB obtained experimentally where all other drilling variables remain



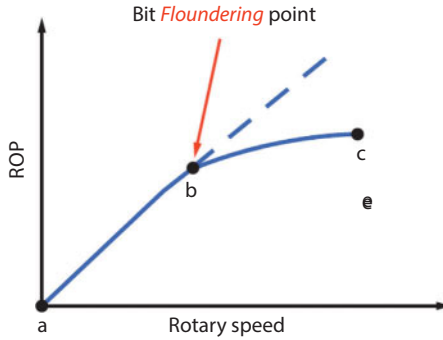

**Figure 2.18** Typical response of ROP to increasing bit weight (Hossain and Al-Majed, 2015).

constant. No significant penetration rate is obtained until the threshold bit weight is exceeded (point a). ROP increases gradually and linearly with increasing values of bit weight for low-to-moderate values of bit weight (segment ab). A linear sharp increase curve is again observed at the high bit weight (segment bc). Although the ROP vs. WOB correlations for the discussed segments (ab and bc) are both positive, segment bc has a much steeper slope, representing increased drilling efficiency. Point b is the transition point where the rock failure mode changes from scraping or grinding to shearing. Beyond point c, subsequent increases in bit weight cause only slight improvements in ROP (segment cd). In some cases, a decrease in ROP is observed at extremely high values of bit weight (segment de). This type of behavior sometimes is called bit floundering (point d – bit floundering point). The poor response of ROP at high WOB values is usually attributed to less-efficient hole cleaning because of a higher rate of cuttings generation, or because of a complete penetration of a bit's cutting elements into the formation being drilled, without room or clearance for fluid bypass.

**ii) Rotary Speed:** Figure 2.19 shows a characteristic shape typical response of ROP vs. rotary speed obtained experimentally where all other drilling variables remain constant. Penetration rate usually increases linearly with increasing values of rotary speed (N) at low values of rotary speed (segment ab). At higher values of rotary speed (after point b, segment b to c), the rate of increase in ROP diminishes. The poor response of penetration rate at high values of rotary speed usually is also attributed to less efficient bottom-hole cleaning. Here, the bit floundering is due to less efficient bottom-hole cleaning of the drill cuttings.

Maurer (1962) developed a theoretical equation for rolling cutter bits relating ROP to bit weight, rotary speed, bit size, and rock strength. The equation was derived from the following observations made in single-insert



**Figure 2.19** Typical response of ROP to increasing rotary speed (Hossain and Al-Majed, 2015).

impact experiments: i) the crater volume is proportional to the square of the depth of cutter penetration, ii) the depth of cutter penetration is inversely proportional to the rock strength. For these conditions, the equation can be written as:

$$ROP = \frac{K}{S_c^2} \left[ \frac{W_b}{d_b} - \left( \frac{W_{bt}}{d_b} \right)_t \right]^2 N \tag{2.18}$$

where,

- $ROP$  = rate of penetration, ft. /min
- $K$  = constant of proportionality
- $S_c$  = compressive strength of the rock
- $W_b$  = bit weight
- $W_{bt}$  = threshold bit weight
- $d_b$  = bit diameter
- $N$  = rotary speed
- $(W_{bt}/d_b)_t$  = threshold bit weight per inch of bit diameter

This theoretical relation assumes perfect borehole cleaning and incomplete bit tooth penetration. Bingham (1965) suggested the following drilling equation on the basis of considerable laboratory and field data. The equation can be written as:

$$ROP = K \left[ \frac{W}{d_b} \right]^{a_5} N \tag{2.19}$$

Here,

- $K$  = constant of proportionality that includes the effect of rock strength  
 $a_s$  = bit weight exponent.

In this equation, the threshold bit weight was assumed to be negligible and bit weight exponent must be determined experimentally for the prevailing conditions.

**iii) Weight on Bit:** The significance of WOB can be shown as explained by Figure 2.18. The figure shows that no significant penetration rate is obtained until the threshold bit weight ( $W_t$ ) is applied (Segment oa, i.e., up to point a). The penetration rate then increases rapidly with increasing values of bit weight (Segment ab). Then a constant rate in increase (linear) in ROP is observed at moderate bit weight (Segment bc). Beyond this point (c), only a slight improvement in the ROP (segment cd) is observed. In some cases, a decrease in penetration rate is observed at extremely high values of bit weight (Segment de). This behavior is called bit floundering. It is due to less efficient bottom-hole cleaning (because the rate of cutting generation has increased).

**5. Drilling Fluid Properties:** The properties of the drilling fluid reported to affect the penetration rate include: i) density, ii) rheological flow properties, iii) filtration characteristics, iv) solids content and size distribution, and v) chemical composition. ROP tends to decrease with increasing fluid density, viscosity, and solids content. It tends to increase with increasing filtration rate. The density, solids content, and filtration characteristics of the mud control the pressure differential across the zone of crushed rock beneath the bit. The fluid viscosity controls the parasitic frictional losses in the drillstring and, thus, the hydraulic energy available at the bit jets for cleaning. There is also experimental evidence that increasing viscosity reduces penetration rate even when the bit is perfectly clean. The chemical composition of the fluid has an effect on penetration rate, such that the hydration rate and bit balling tendency of some clays are affected by the chemical composition of the fluid. An increase in drilling fluid density causes a decrease in penetration rate for rolling cutter bit. An increase in drilling fluid density causes an increase in the bottom hole pressure beneath the bit and, thus, an increase in the pressure differential between the borehole pressure and the formation fluid pressure.

**6. Bit Tooth Wear:** Most bits tend to drill slower as the drilling time elapses because of tooth wear. The tooth length of milled tooth rolling cutter bits

is reduced continually by abrasion and chipping. The teeth are altered by hard facing or by case-hardening process to promote a self-sharpening type of tooth wear. However, while this tends to keep the tooth pointed, it does not compensate for the reduced tooth length. The teeth of tungsten carbide insert-type rolling cutter bits and PDC bits fail by breaking rather than by abrasion. Often, the entire tooth is lost when breakage occurs. Reductions in penetration rate due to bit wear usually are not as severe for insert bits as for milled tooth bits unless a large number of teeth are broken during the bit run.

**7. Bit Hydraulics:** Significant improvements in penetration rate could be achieved by a proper jetting action at the bit. The improved jetting action promoted better cleaning of the bit face as well as the hole bottom. There exists an uncertainty on selection of the best proper hydraulic objective function to be used in characterizing the effect of hydraulics on penetration rate. Bit hydraulic horsepower, jet impact force, Reynolds number, etc., are commonly used objective functions for describing the influence of bit hydraulics on ROP.

**8. Directional and Horizontal Well Drilling:** Since the 1980s, when the horizontal well technology was 'perfected', the majority of the wells in the developed world use horizontal wells. This is also accompanied by inclined and directional wells that had already gained usefulness in offshore drilling. Common field of applications for directional and horizontal drilling are in offshore and onshore, where vertical wells are impractical to drill or much higher return for investment is assured with horizontal wells. Over the last three decades, there has been a major shift from vertical to horizontal wells. The use of horizontal wells has allowed for greater formation access. As more and more horizontal wells are drilled, the cost of horizontal well drilling declines. As IEA report (2016) indicates, over the past decades, lateral lengths have increased from 2,500 feet to nearly 7,000 feet and, at the same time, we have seen nearly a threefold increase in drilling rates (feet/day). This is shown in Figure 2.20. Even though such an increase in efficiency in horizontal well has driven the drilling cost down, the technology has not caught on in the developing countries, where horizontal wells are still deemed prohibitively expensive.

The major applications of directional drilling are to i) develop the fields which are located under population centers, ii) drill wells where the reservoir is beneath a major natural obstruction, iii) sidetrack out of an existing well bore, and iv) elongate reservoir contact and thereby enhance well productivity (Hossain and Al-Majed, 2015).

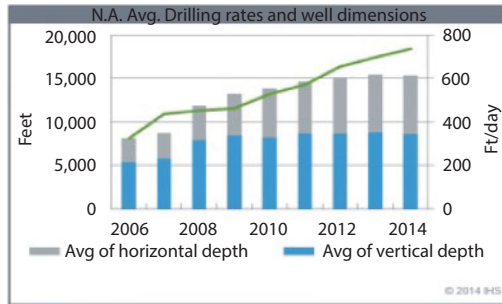
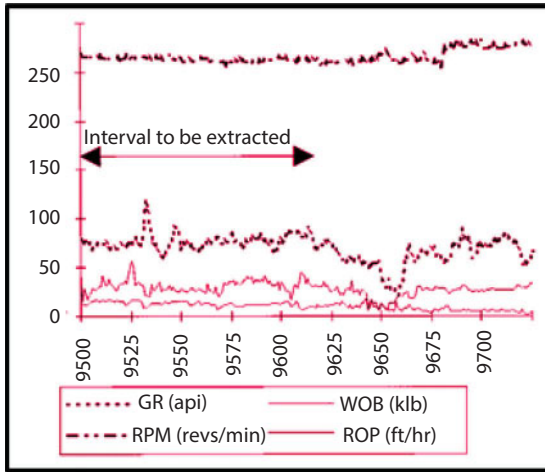

Figure 2.20 Historical drilling trend (from EIA Report, 2016).

**9. Improve ROP in Field Operations:** Time spent to drill ahead is usually a significant portion of total well cost. Rotating time usually accounts for 10% to 30% of well cost in typical wells. This means that the penetration rate achieved by the drill bit has considerable impact on reduction on drilling cost. A method has been developed to identify which factors are controlling ROP in a particular group of bit runs. The method uses foot-based mud logging data, geological information, and drill bit characteristics to produce numerical correlations between ROP and applied drilling parameters or other attributes of drilling conditions. These correlations are then used to generate recommendations for maximizing ROP in drilling operations. The objective of this method is to quantify the effects of operationally controllable variables on ROP. To reveal the effects of these variables, data sets must be constructed so as to minimize variation in environmental conditions. The first step is therefore to select a group of bit runs made with the same bit size through similar formations. Next, intervals of consistent lithology are identified with a preference for formations exhibiting lateral homogeneity. Formations such as shale and limestone are in general more suitable than variable lithologies such as sandstone. Rock property logs can be used to verify comparability. Further sorting can be made depending on the objectives of each specific analysis to separate bit runs in different mud types with different classes of bit or to separate intervals drilled with sharp bits versus those in worn condition. Each step helps to further expose the effects on ROP of bit design, and mechanical or hydraulic drilling parameters. Once intervals have been selected and sorted, numerical averages of the variables of interest are obtained. This is critical because many sources of error exist in drilling parameter measurements, and improvement in data quality. Averaging to raise sample size is the most obvious method to minimize the effects of error.

Figure 2.21 shows a log, for which data have been extracted and averaged from an interval of shale early in the bit run, prior to a drop in ROP



**Figure 2.21** Example of bit-run data showing interval to be extracted and averaged (Fear, 1999).

related to bit wear in a sandstone. This process would then be repeated for other bit runs made through the same stratigraphic interval, yielding a data set suitable for analysis. For example, BP Exploration customized petrophysical software which is used to automate the extraction and averaging of drilling data through manual processing from paper logs. Once data are prepared, correlation analysis is performed in conventional spreadsheets. Cross plots are used to seek visible correlations between ROP and the independent variables, and statistics functions are used to establish the degree of correlation and to build models for prediction of ROP.

**Case Study:** A six-bladed 12-1/4" CDE PDC bit with 16 mm cutters was tested in the Zubair field in Iraq. The attempt was to solve vibration issues which was causing low ROP. The formation consisted of medium-hard carbonates and interbedded intervals. A significant increase in ROP was achieved since the stick-slip and vibration levels were reduced. Hence, the WOB could be increased. The ROP was increased with 29% compared to the best offset run of 18.5 m/hr, and with 56% compared to the average of all three offset wells of 15.3 m/hr (Figure 2.22). The improvement in ROP is directly attributed to the added CDE technology, as all three bits were run on the same type of rotary steerable BHA. The CDE PDC bit showed no wear on the cutting structure or on the conical element after drilling 595 m. Due to the increased ROP the cost/meter was reduced by 27% when using the Stinger bit (Figure 2.23) compared to the best offset. This operation saved \$32,000 for the operator.

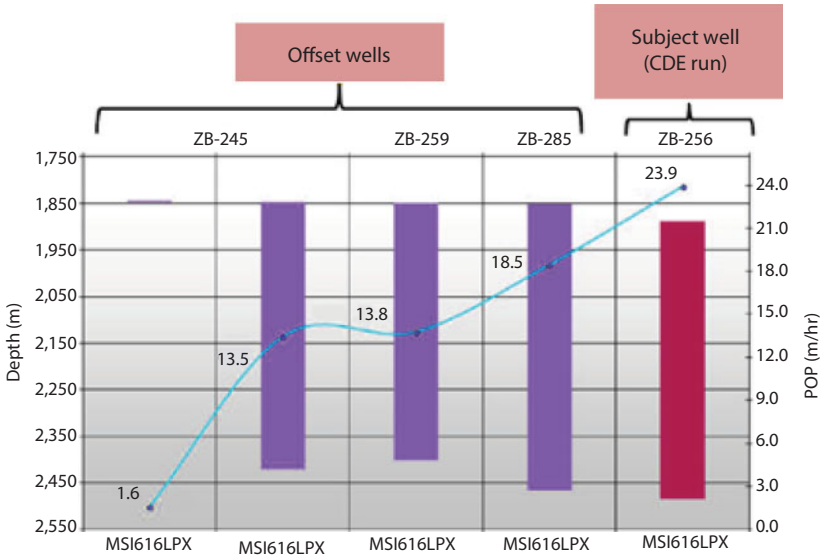

Figure 2.22 ROP for different wells.



Figure 2.23 Stinger bit crush and shear the cuttings.

### Recommendations

- Any ROP model should estimate penetration rate as a function of many drilling variables such as weight on bit, rotary speed, flow rate, nozzle diameters, drilling fluid density and viscosity, bed height, and cuttings concentration in the annulus with a reasonable accuracy.
- Use modern well monitoring equipment.
- To increase the accuracy of any ROP model, it is necessary to use data from more than a single well. In addition, these data should be from a single formation.

- Because of the structure, geometry, number, and size of the nozzles of PDC bits, the pump-off force play an effective roll on the weight on bit. Therefore, special care should be taken.

### 2.1.8 Marginal Aquifer Encountered

An aquifer can be defined as a water-bearing portion of a petroleum reservoir where the reservoir has a water drive. In general, water-bearing rocks are permeable which allows fluid to pass while production starts. Sometime, drillers encounter marginal aquifer while drilling. This is a concern for the people who are engaged with drilling activities because drilling fluid may contaminate the aquifer fresh water. Thus, additional precautions are needed during the design and execution of the well plan to protect fresh water aquifers. In addition, aquifer water can flow into the wellbore, and thus contaminate the drilling fluids, which may cause well control problem.

**Solution:** To avoid the above problems, drillers need to confirm that the drill bit penetrates the full thickness of the aquifer. It should extend as far below it as possible. Install the well screen adjacent to the entire aquifer thickness with solid casing installed above and below it. After developing the well, install the pump cylinder as low as possible in the well. If a well is being completed in a fine sand/silt aquifer within 15–22 m (50–75 ft) of ground surface, a 20 cm (8 in) reamer bit is sometimes used (e.g., Bolivia). This makes it possible to install a better filter pack and reduces entrance velocities and passage of fine silt, clay and sand particles into the well. Further, the success can be maximized by adding a small amount of a polyphosphate to the well after it has been developed using conventional techniques. The polyphosphate helps to remove clays which occur naturally in the aquifer. This clay contaminates the drilling fluid. Therefore, it is also important to remove the clay during the process.

### 2.1.9 Well Stops Producing Water

The reservoir pores contain the natural fluids (e.g., water, oil, gas etc.) at chemical equilibrium. It is well known that reservoir rocks are generally of sedimentary origin. Therefore, water was present at the beginning and thus is trapped in the pore spaces of rocks. This natural fluid (i.e., water) may migrate according to the hydraulic pressures induced by geological processes that also form the reservoirs. In hydrocarbon reservoirs, some of the water is displaced by the hydrocarbon; however, some water always remains in the pore space. If there is a water drive from a sea or ocean, then



it will be acting as a pressure maintenance drive. On several occasions, during production, sometimes it is experienced that there is no water production or little water production. Thus, the reservoir pressure drops down, which affects the hydrocarbon production.

### **2.1.10 Drilling Complex Formations**

Complex reservoir is defined as a distinct class of reservoir, in which fault arrays and fracture networks exert an overriding control on petroleum trapping and production behavior, characterized by the interplay of different factors during the development of the reservoir properties of the field. In such type of reservoir, study on reservoir characteristics become challenging when the parameters such as fracturing and faulting; complex distribution of primary and secondary petrophysical properties; relationship between the structural elements and the “matrix” characteristics; and structural features and diagenetic evolution become significant. Even with modern exploration and production portfolios commonly held in geologically complex settings, there is an increasing technical challenge to find new prospects in drilling, development, and finally to extract remaining hydrocarbons from the complex reservoirs. Improved analytical and modeling techniques will enhance our ability to locate connected hydrocarbon volumes and unswept sections of reservoir, and thus help optimize field development, production rates and ultimate recovery. The depositional factors play a vital role in this case. The factors can significantly influence reservoir properties, including initial fluid saturations, residual saturations, waterflood sweep efficiencies, preferred directions of flow, and reactions to injected fluids. The permeability barriers may lead to the need to drill additional infill wells or reposition the locations of such wells, selectively perforate and inject reservoir units, manage zones on an individual basis, and revise decisions regarding suitability for thermal recovery operations. In order to increase the rate of penetration (ROP) and to reduce cost for drilling complex reservoir, there is a need for special bit structure, drilling methods and drilling parameters.

### **2.1.11 Complex Fluid Systems**

It is very important to have a comprehensive understanding of the complex fluid system and its behavior under different scenarios such as drilling, production, depletion and developments to increase oil and gas production as well as safe drilling. Complex fluids and complex fields add more challenges to the conventional drilling, and scenarios. Therefore, as a petroleum engineer, it is essential to understand the challenges, options and best

practices dealing with the complex reservoir fluid systems both in the oil and gas industries. A thorough study needs to be done on various aspects of complex fluids characterization of oil and gas reservoirs to reduce the risk and uncertainty. Significant complexities exist in oil and gas reservoirs in terms of reservoir architecture and fluids. Fluid complexities viz. compositional gradation and variation, impurities and drastic spatial variations impact the recovery and production from the field. In the majority of cases, these complexities are not understood and recognized due to limited data and lack of analysis and appropriate tools used for capturing the data. These data are very crucial for reservoir engineering study, processing and flow assurance in wellbore and pipelines.

### 2.1.12 Bit Balling

Bit balling is one of the drilling operational issues which can happen anytime while drilling. Bit balling is defined as the sticking of cuttings to the bit surface when drilling through Gumbo clay (i.e., sticky clay), water-reactive clay, and shale formations. During drilling through such formation, as the bit is rotating in the bottom hole, some of this clay get attached to the bit cones (Figure 2.24). If the bit cleaning is not proper, which happens usually due to poor hydraulics, more and more of this clay sticks to the bit. Finally, a stage is reached where all the cones are covered with this clay and further drilling is not possible. Bit balling can cause several problems such as reduction in rate of penetration (ROP), increase in torque, increase in stand pipe pressure (SSP) if the nozzles are also stuck. Since drilling is not



Figure 2.24 Drilling bit balled up.

happening the volume of cuttings on the shale shaker are also reduced. Personnel may eventually need to pull out of hole the bottomhole assembly (BHA) to clear the balling issue at the bit.

There are many factors that affect the bit balling. These factors are: (i) formation – clay stone and shale has a tendency to ball up the bit even though one uses highly inhibitive water-based mud or oil-based mud; (ii) calcite content in clay – e.g., highly reactive clays with large cation exchange capacities; (iii) hydrostatic pressure in wellbore – high hydrostatic pressure (e.g., 5000 – 7000 psi) can induce bit balling issue in water-based mud; (iv) weight on bit – high weight on bit will have more chance to create this issue; (v) bit design – poor bit cutting structure and poor junk slot area in PCD bits contribute to this issue; (vi) poor projection of bit cutting structure due to inappropriate bit choice or bit wear; (vii) poor bit hydraulics – low flow rate will not be able to clean the cutting around the bit; (viii) poor open face volume (i.e., junk slot area) on PDC bits.

If there is a doubt that bit balling is going to be happening, it can be recognized by: (i) the ROP will decrease more than projection. For example, if crew drills 100 ft/hr and later the ROP drops to 50 ft/hr without any drilling parameters changed (e.g. less than expected in soft rock); (ii) drilling torque – drilling torque will be lower than normal drilling torque since most of the cutters are covered up by cuttings decrease in torque (i.e., less than expected and may show decrease with time); (iii) weight on bit – added weight on bit resulting in static or negative ROP reaction; (iv) standpipe pressure – standpipe pressure increases with no changes in flow rates or drilling parameters. Balling up around the bit reduce annular flowing area resulting in increasing pressure (e.g., 100–200 psi with a PDC bit with no associated increase in flow).

If there is a problem associated with bit balling while drilling, a proper plan should be implemented to avoid the bit balling. These plans are: (i) Bit selection – select bit with maximum cutting structure projection (e.g., steel tooth bits are better than insert bits because the steel tooth ones have greater teeth intermesh. Therefore, steel tooth is preferred over similar insert bit to help clean cutting structure). For the PCD bits, the larger junk slot area is preferred. (ii) Bit nozzle selection – the bits with high flow tube or extended nozzles are not recommended. Some jetting action must be directed onto the bit cutting structure. If the bigger bit size is utilized, we should not block off the center jet. The center jet will flush all cutting more effectively. Use tilted nozzles to direct some flow onto the cones of the bit. (iii) Good hydraulic – hydraulic horse power per cross sectional area of the bit is the figure which can be utilized for measuring good hydraulic for bit balling mitigation. Hydraulic horsepower per square inch (HSI) less

than 1.0 will not be able to clean the bits. It is good practice to have more than 2.5 of HSI for good bit cleaning in a balling environment. However, do not maximize flow rate at the expense of HSI. (iv) Drilling fluid – mud chemical additives such as partially hydrolyzed poly acrylamide (PHPA) which can prevent clay swelling issue must be added into the water-based mud system. If feasible, drilling with oil-based fluid will have less chance of balling up. (v) Weight on Bit (WOB) – the driller should not try to run a lot of WOB. If WOB is increased and then lower ROP is encountered, the driller may have bit balling up issue. In such case, the driller should lower the weight and attempt to clean the bit as soon as possible. Hence, if ROP falls do not increase WOB as a response. Alert crew to this situation.

Once bit balling has been detected, there are some jobs need to be done immediately. These jobs can be listed as: (i) Stop drilling and pick up off bottom – if the drilling operation keeps continuing, it will make the situation even worse. It is a good practice to stop and pick up off bottom to fix the issue quickly. (ii) Increase RPM and flow rate – increasing RPM will spin the cutting around the bit more. Additionally, increase flow rate to the maximum allowable rate will help clean the bit. (iii) Monitor pressure – if you see decreasing in standpipe pressure to where it was before, it indicates that some of cuttings are removed from the bit. (iv) Lower WOB – Drill with reduced weight on bit. (v) Pump high viscosity pill – pumping high viscosity pill may help pushing out the cutting. (vi) Fresh water pill – leave to soak and try to dissolve/loosen balled material. This will help that lithology become more silty or sandy, which may help clear bit, and prepare to trip if these actions are not successful and choose more optimum, bit, hydraulics nozzle arrangement or mud system.

### 2.1.13 Formation Cave-in

The main cause of borehole caving (collapse) is simply the lack of suitable drilling mud. This often occurs in sandy soils where drillers are not using good bentonite or polymer. Now, the formation cave-in is defined as “pieces of rock that come from the wellbore; however, these pieces were not removed directly by the action of the drill bit”. Cavings can be splinters, shards, chunks and various shapes of rock. These parts normally spall from shale sections and they become unstable (Figure 2.25). The shape of the caving can reveal the answer why the rock failure occurs. The term is typically used in the plural form. The main cause of borehole caving is lack of suitable drilling mud. This often occurs in sandy soil where drillers are not using good bentonite or polymer. The problems can be observed when fluid is circulating but cuttings are not being carried out of the hole.

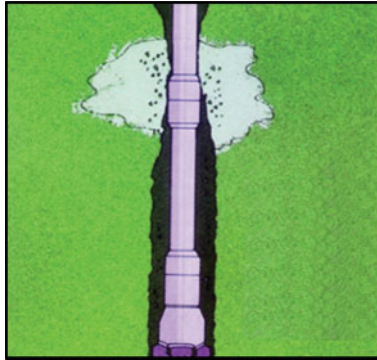

**Figure 2.25** Formation cave-in.

In such a situation, if the driller continues to push ahead and drill, the bit can become jammed. The hole will collapse when the casing team tries to insert the casing or the huge portion of the aquifer may wash out, making it very difficult to complete a good well. The solution is to get some bentonite or polymer or, if necessary, assess the suitability of natural clay for use as drilling fluid. Borehole caving can also happen if the fluid level in the borehole drops significantly. Therefore, it is necessary to have a loss of circulation or a night time stoppage, and thus slowly refill the borehole by circulating drilling fluid through the drillpipe. However, pouring fluid directly into the borehole may trigger caving. If caving occurs while drilling, check if cuttings are still exiting the well. If they are, stop drilling and circulate drilling fluid for a while. Sometimes part of the borehole caves while the casing is being installed, preventing it from being inserted to the full depth of the borehole. When this appears, the casing must be pulled out and the well redrilled with heavier drilling fluid. When pulling the casing, no more than 12.19 m (40 ft) should be lifted into the air at any time. If the driller pulls the pipe more than the specified length, it will cause thin-walled PVC to bend and crack.

#### 2.1.14 Bridging in Wells

Bridging is defined as “a cave-in from an unstable formation that may trap the drillstring” (Figure 2.26). Bridging may be the result of insufficient mud pressure. However, there are different definitions of bridging based on applications. For example, in the drilling point of view, the bridging in the well is defined as “to intentionally or accidentally plug off pore spaces or fluid paths in a rock formation, or to make a restriction in a wellbore or annulus”. A bridge may be partial or total, and is usually caused by solids (e.g., drilled

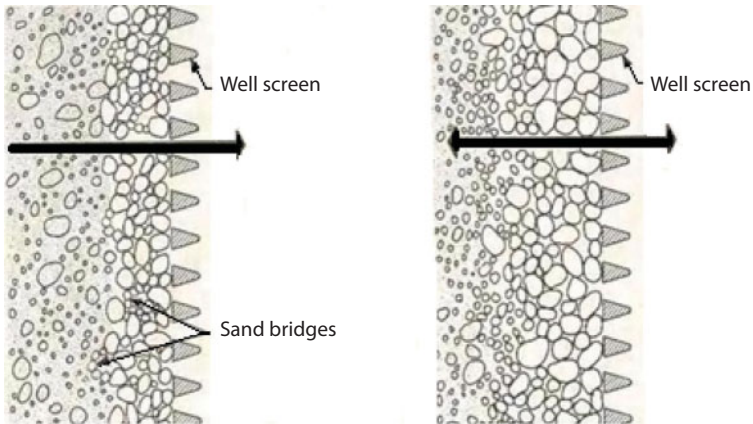

Figure 2.26 Bridging in Wells.

solids, cuttings, cavings or junk) becoming stuck together in a narrow spot or geometry change in the wellbore. From a well completion point of view, it can be expressed as “a wellbore obstruction caused by a buildup of material such as scale, wellbore fill or cuttings that can restrict wellbore access or, in severe cases, eventually close the wellbore”. In well workover, bridge is the “accumulation or buildup of material such as sand, fill or scale, within a wellbore, to the extent that the flow of fluids or passage of tools or downhole equipment is severely obstructed”. In extreme cases, the wellbore can become completely plugged or bridged-off, requiring some remedial action before normal circulation or production can be resumed. In perforating/well completions, bridge plug is outlined as “a downhole tool that is located and set to isolate the lower part of the wellbore. Bridge plugs may be permanent or retrievable, enabling the lower wellbore to be permanently sealed from production or temporarily isolated from a treatment conducted on an upper zone”. In well completions, a retrievable bridge plug is described as “a type of downhole isolation tool that may be unset and retrieved from the wellbore after use, such as may be required following treatment of an isolated zone”. A retrievable bridge plug is frequently used in combination with a packer to enable accurate placement and injection of stimulation or treatment fluids. Bridging can be from: (i) cutting slump; (ii) formation cave-in; (iii) formation extrusion around a tectonically active area or salt diapirs.

A bridge plug is a tool used in downhole applications in the oil drilling industry. The bridge plug is used in the wellbore or underground to stop a well from being used. A bridge plug has both permanent and temporary applications. It can be applied in a fashion that permanently ceases oil production occurring from the well where it is applied. It can be also

manufactured in a way which makes it retrievable from the wellbore. Thus, it allows production from the well to resume. They can also be used on a temporary basis within the wellbore to stop crude oil from reaching an upper zone of the well while it is being worked on or treated. Bridge plugs are typically manufactured from several materials that each have their own applicable benefits and disadvantages. For instance, bridge plugs made from composite materials are often used in high-pressure applications because they can withstand pressures of 18,000–20,000 psi (124–137 MPa). On the other hand, their permanent use tends to lend itself to slippage over time due to the lack of bonding between the composite materials and the materials inside the wellbore. Bridge plugs fabricated out of cast iron or another metal may be perfect for long-term or even permanent applications. However, they don't adhere very well in high-pressure situations.

Bridge plugs do not just get placed in a wellbore and left to plug the end. In fact, placing a bridge plug within a wellbore to either permanently or temporarily stop the flow of oil or gas is an intensive process that must be done tactically and skillfully. It must be done while utilizing a bridge plug tool which is specially designed to place bridge plugs in an efficient manner. The tool used to place the plug usually has a tapered and threaded mandrel which is threaded into the center of the bridge plug. It has compression sleeves placed in succession with each other so that as the tool engages the plug, the sleeves compress around the plug and the tool rotates the plug downhole into the wellbore. When the bridge plug is at the desired depth, the tool is disengaged from the axial center of the plug, and unthreaded from the cylinder. The tool is removed from the wellbore with the plug being left in place, as the sleeves have decompressed.

#### *2.1.14.1 Causes of Bridging in Wells*

There are several reasons for bridging in the well. For example: (i) Cutting problems: one of the primary functions of the drilling mud is the efficient transportation of cuttings to the surface. This function depends essentially on the fluid velocity and other parameters such as the fluid rheological properties, cuttings size, etc. The cuttings must be removed from the formation to allow further drilling. Otherwise, bridging will happen. (ii) Cutting settling in vertical or near vertical wellbore: vertical or near vertical wells have inclination less than 35°. It is a well-known fact that drilling mud is a mixture of fluids such as water, oil or gases and solids (i.e., bentonite, barite etc.). The solids such as sand, silt, and limestone do not hydrate or react with other compounds within the mud and are being generated as cuttings from the formation while drilling. These solids are called inert and must be

removed to allow efficient drilling to continue. Therefore, solid control is defined as the control of the quantity and quality of suspended solids in the drilling fluid to reduce the total well cost. However, some particles in the mud (i.e., barite, bentonite) should be retained since they are required to maintain the properties of the mud. The rheological and filtration properties can become difficult to control when the concentration of drilled solids (low-gravity solids) becomes excessive. If the concentration of drill solids increases, penetration rates and bit life decrease. On the other hand, hole problems increase with the increase of drill solids concentration.

Bridging can happen when cuttings in the wellbore are not removed from the annulus. This problem can happen when there is not enough cutting slip velocity in and/or drilling mud properties in the wellbore is bad. When pumps are off, cuttings fall down the formation bed due to gravitational force and pack and annulus. Finally, it results in stuck pipe. It is noted that to clean annulus effectively, the annular velocity must be more than cutting slip velocity in dynamic condition. Moreover, mud properties must be able to carry cutting when pumps are on and suspend cutting when pumps are off.

#### 2.1.14.2 *Warning Signs of Cutting Setting in Vertical Well*

- There is an increase in torque/drag and pump pressure
- An over pull may be observed when picking up and pump pressure required to break circulating is higher without any parameters change
- Indications when pipe is stuck due to cutting bed in vertical well
- When this stuck pipe caused by cutting settling is happened, circulation is restricted and sometimes impossible. It most likely happens when pump off (making connection) or tripping in/out of hole.

#### 2.1.14.3 *Remedial Actions of Bridging in Wells*

- Attempt to circulate with low pressure (300–400 psi). Do not use high pump pressure because the annulus will be packed harder and you will not be able to free the pipe anymore.
- Apply maximum allowable torque and jar down with maximum trip load. Do not try to jar up because you will create a worse situation.
- Attempt to circulate with low pressure (300–400 psi). Do not use high pump pressure because the annulus will be packed harder and you will not be able to free the pipe anymore.



- Apply maximum allowable torque and jar down with maximum trip load. Do not try to jar up because you will create a worse situation.

2.1.14.4 Preventive Actions

Ensure that annular velocity is more than cutting slip velocity.

- Ensure that mud properties are in good shape.
- Consider pump hi-vis pill. You may try weighted or unweighted and see which one gives you the best cutting removal capability.
- If you pump sweep, ensure that sweep must be return to surface before making any connection. For a good drilling practice, you should not have more than one pill in the wellbore.
- Circulate hole clean prior to tripping out of hole. Ensure that you have good reciprocation while circulating.
- Circulate 5–10 minutes before making another connection to clear cutting around BHA.
- Record drilling parameters and observe trend changes frequently.
- Optimize ROP and hole cleaning.

2.1.14.5 Volume of Solid Model

During drilling operation, huge amounts of rock chips are generated due to the cutting of earth rock. Therefore, it is very important to know the solid volume of rock fragments that comes to the surface with the drilling mud. In an ideal situation, all drill solids are removed from a drilling fluid. Under typical drilling conditions, low-gravity solids should be maintained below 6% by volume. Drill cuttings are the volume of rock fragments generated by the bit per hour of drilling. The following equation (Equation 2.20) can be used to estimate the volume of solids entering to the mud system while drilling.

$$V_s = \frac{\pi(1 - \phi_A)d_B^2}{4} R_{ROP} \tag{2.20}$$

Here

- $d_B$  = bit diameter
- $V_s$  = solid volume of rock fragments entering the mud i.e., volume of cuttings
- $R_{ROP}$  = rate of penetration of the bit
- $\phi_A$  = average formation porosity

In field unit, Eq. (2.20) can be written as

$$V_s = \frac{\pi(1 - \phi_A)d_B^2}{1029} R_{ROP} \quad (2.21a)$$

Here

- $d_B$  = bit diameter, in
- $V_s$  = solid volume of rock fragments entering the mud i.e.,  
volume of cuttings, bbl/hr
- $R_{ROP}$  = rate of penetration of the bit, ft /hr
- $\phi_A$  = average formation porosity, vol. fraction

If,  $V_s$  is in tons/hr,  $d_b$  is in inch and  $R_{ROP}$  is in ft /hr, Eq. (2.20) can be obtained as:

$$V_s = \frac{(1 - \phi_A)d_B^2}{2262} R_{ROP} \quad (2.21b)$$

These solids (except barite) are considered undesirable because

- i. They increase frictional resistance without improving lifting capacity,
- ii. They cause damage to the mud pumps, leading to higher maintenance costs, and
- iii. Filter cake formed by these solids tends to be thick and permeable. This leads to drilling problems (stuck pipe, increased drag) and possible formation damage.

The reason that cuttings tend to settle on the low side of inclined wells, and some indicators of cuttings accumulations, are considered in this section. Focus will also be placed on the following: cutting accumulation in cavities, removal of cuttings from well, guidelines used in deviated wellbore during cuttings removal in washout, and comparison of published research done on cuttings removal in washout. Infoshost (2012) revealed that accumulation of cuttings can occur in wells that do have adequate hole cleaning. This is common directional or horizontal wells. Increasing circulating pressure while drilling, or increase in drag pipe causes/363-mechanical-sticking-cause-of stuck-pipe. It is noted that cuttings accumulation is indicated by:

- Reduced cutting on the shale shaker
- Increased over pull

- Loss of circulation
- Increase in pump pressure without changing any mud properties
- While drilling with a mud motor, cutting cannot be effectively removed due to no pipe rotation
- Drilling with high angle well (from 35 degrees up)
- Abnormality in torque and drag with the help of a trend (increase in torque/drag)

## 2.2 Summary

This chapter discusses major drilling problems and their solutions related to drilling rig and operations only. The different drilling problems encountered in drilling are explained, along with their appropriate solutions and preventative measures. Each major problem solution is also complemented with case studies.

## References

- Adkins, C.S. (1993). Economics of Fishing: SPE Technical Paper 20320.
- Alum, M.A.O and Egbon, F. (2011). Semi-Analytical Models on the Effect of Drilling Fluid Properties on Rate of Penetration (ROP). SPE 150806, presented at the Nigeria Annual International Conference and Exhibition, Abuja, Nigeria, July 30–August 3, 2011.
- Asch, S E. (1956). Studies of Independence and Submission to Group Pressure. Psychological Monographs, 70(9).
- Australian Drilling Industry Training Committee Ltd. (1992). *Australian Drilling Manual* 3<sup>rd</sup> edition. Macquarie Centre: Australian Drilling Industry Training Committee Ltd, ISBN 0-949279-20X.
- Ayres R.C. and O'Reilly J.E. (1989). Offshore operators Committee Gulf of Mexico spotting Fluid Survey. paper SPE/IADC 18683 presented at SPE/IADC Drilling Conference, New Orleans.
- Billings, C.E. (1996). Human-Centered Aviation Automation: Principles and Guidelines. NASA Technical Memorandum 110381, Moffet Field, California: Ames Research Center.
- Black, A.D. *et al.* (1986). PDC Bit Performance for Rotary, Mud Motor, and Turbine Drilling Applications. *SPE Drill. Complet.* 409 (December 1986).
- Bradley W.B., Jarman D., Plott R.S., Wood R.D., Schofield T.R., Auflick R.A. and Cocking D. (1991). A Task Force Approach to Reducing Stuck Pipe Costs. paper SPE/IADC 21999 presented at SPE/IADC Drilling Conference, Amsterdam, 1991.

- Bredereke, J. and Lankenau, A. (2002). A Rigorous View of Mode Confusion. In Computer Safety, Reliability, and Security, Proceedings of the 21st International Conference, SAFECOMP (Catania, Italy, 10–13 September), ed. S. Anderson, M. Felici and S. Bologna, 19–31. Berlin/ Heidelberg: Springer.
- Cayeux, E. and Daireaux, B. (2009). Early Detection of Drilling Conditions Deterioration Using Real-Time Calibration of Computer Models: Field Example from North Sea Drilling Operations. Paper SPE 119435 presented at the SPE/IADC Drilling Conference and Exhibition, Amsterdam, The Netherlands, 17–19 March.
- Chatfield C. (1970). *Statistics for Technology*. Chapman and Hall, London.
- Cobb, C.C., and Schultz, P.K. (1992). A Real-Time Fiber Optic Downhole Video System. paper OTC 7046, presented at the 1992 24th Annual Offshore Technology Conference, Houston, TX, May 4–7.
- Coolican, H. (1990). *Research Methods and Statistics in Psychology*. Hodder & Stoughton: London.
- Cunha, J.S., and D'Almeida, A.L. (1996). *Implementation of a Risk Analysis*, Boyd Publishing, p. 271–453.
- Cunningham, R.A. and Eenink, J.G. (1959). Laboratory Study of Effect of Overburden, Formation and Mud Column Pressure on Drilling Rate of Permeable Formations., *J. Pet. Technol.* 9 (January 1959).
- D'Almeida, A.L., I.A. Silva, and J.S. Ramos, A F, Detournay, E. and Atkinson, C. (1997). Influence of Pore Pressure on the Drilling Response of PDC bits. *Rock Mechanics as a Multidisciplinary Science*, Roegiers (ed.), Balkema, Rotterdam (1991) 539.
- Driscoll, F. (1986). *Groundwater and Wells*, St. Paul: Johnson Division Engineering, Dallas, Boyd Publishing, p. 133–271.
- EIA Report, 2016, *Trends in U.S. Oil and Natural Gas Upstream Costs*, March, available at <https://www.eia.gov/analysis/studies/drilling/pdf/upstream.pdf>.
- Fowler Jr., S.H., and Pleasants, C.W. (1990). Operation and Utilization of Hydraulic-Actuated Service Tools for Reeled Tubing. paper SPE 20678 presented at the 1990 65th Annual Technical Conference & Exhibition of SPE, New Orleans, LA, September 23–26.
- Gill, J.A. (1983). Hard Rock Drilling Problems Explained by Hard Rock Pressure Plots. SPE-11377-MS, presented at the IADC/SPE Drilling Conference, 20–23 February, New Orleans, Louisiana.
- Gray-Stephens, D., Cook, J.M., and Sheppard, M.C. (1994). Influence of Pore Pressure on Drilling Response in Hard Shales. *SPE Drill. Complet.* 263 (December 1994).
- Hendrick, K. & Brenner, L. (1987) *Investigating Accidents with STEPP*. Dekker: New York.
- Hourizi, R. and Johnson, P. (2001). Beyond mode error: Supporting strategic-knowledge structures to enhance cockpit safety. In Blandford, A., Vanderdonk, J., and Gray, P. (Eds.), *People and Computers XV – Interaction without frontiers*. Joint Proceedings of HCI2001 and ICM2001, Lille: Springer Verlag.

- Irawan, S. Rahman, A.M.A. and Tunio, S.Q. (2012). Optimization of Weight on Bit During Drilling Operation Based on Rate of Penetration Model, *Research Journal of Applied Sciences, Engineering and Technology* 4(12): 1690–1695, 2012.
- Iversen, F.P., Cayeux, E., Dvergsnes, E.W. *et al.* (2009). Offshore Field Test of a New System for Model Integrated Closed-Loop Drilling Control. *SPE Drill & Compl J.* 24 (4): 518–530.
- Janis, L.L. (1968) *Victims of Group Think*. Houghton Mifflin.
- Keller P.S., Brinkmann P.E. and Taneja P.K. (1984). Economic and statistical Analysis of Time Limitations for Spotting Fluids and Fishing operations. paper OTC 4792 presented at 16th OTC, Houston, 1984.
- Larsen, H.F., Alfsen, T.E., Kvalsund, R. *et al.* (2010). The Automated Drilling Pilot on Statfjord C. Paper SPE 128234 presented at the IADC/ SPE Drilling Conference and Exhibition, New Orleans, Louisiana, 2–4 February.
- Method on Fishing Operations Decisions: SPE Technical Paper 36101.
- Moore, S.D. (1990). The Coiled Tubing Boom. *Petroleum Engineer International* (April 1991) 16–20.
- Mullin, M.A., McCarty, S.H., and Plante, M.E. (1991). Fishing With 1.5 and 1.75 Inch Coiled Tubing at Western Prudhoe Bay, Alaska. paper SPE 20679, presented at the International Arctic Technology Conference, Anchorage, AK, May 29–31, 1991.
- Osgouei, R.E. (2007). Rate of Penetration Estimation Model for Directional and Horizontal Wells. MSc thesis, Petroleum and Natural Gas Engineering, Middle East Technical University, Turkey.
- Patrick, J., Spurgeon, P. & Shepherd, A. (1986). *A Guide to Task Analysis: Applications-of-Hierarchical Methods*. An Occupational Services Publication.
- Peltier, B. and Atkinson, C. (1986). Dynamic Pore Pressure Ahead of the Bit. paper IADC/SPE 14787, Presented at the 1986 IADC/SPE Drilling Conference, Dallas, TX, 10–12 February.
- Rademaker, R.A., Olszewski, K.K., Goiffon, J.I., and Maddox, S.D. (1992). A Coiled-Tubing-Deployed Downhole Video System. paper SPE 24794, presented at the 1992 67th Annual Technical Conference & Exhibition of SPE, Washington, DC, October 4–7.
- Robison, C.E., and Cox, D.C. (1992). Alternate Methods for Installing ESP's. paper OTC 7035, presented at the 24th Annual Offshore Technology Conference, Houston, TX, May 4–7, 1992.
- Shivers III R.M., and Domangue R.J. (1991). Operational Decision Making for Stuck Pipe Incidents in the Gulf of Mexico: A Risk Economics Approach. paper SPE/IADC 21998 presented at SPE/IADC Drilling Conference, Amsterdam, 1991.
- Sinclair, M. (1995). Subjective Assessment. In: Wilson, J. & Corlett, N. (eds) *Evaluation of Human Work*. Taylor & Francis: London
- Stanton, N. A. (1995). Analysing Worker Activity: A New Approach to Risk Assessment? *Health and Safety Bulletin* 240 (December), 9–11.
- Walker, E.J., and Schmohr, D.R. (1991). The Role of Coiled Tubing in the Western Operating Area of the Prudhoe Bay Unit. paper SPE 22959, presented at the SPE Asia-Pacific Conference, Perth, Western Australia, November 4–7, 1991.

- Warren, T. and Smith, M.B. (1985). Bottomhole Stress Factors Affecting Drilling Rate at Depth,” JPT 1523 (August 1985).
- Website 1 [http://wiki.aapg.org/Diagenetically\\_complex\\_reservoir\\_evaluation](http://wiki.aapg.org/Diagenetically_complex_reservoir_evaluation)
- Wilson, J. (1995). A Consideration of Human Factors When Handling Kicks. Presented to the Well control Conference for Europe. Milan, Italy, June 1995.
- Wilson, J. (1994). Analysis of Kick Data. HSE Report.
- Zhu, H., Deng, J., Xie, Y., Huang, K., Zhao, J., and Yu, B. (2012). Rock mechanics characteristic of complex formation and faster drilling techniques in Western South China Sea oilfields. *Ocean Engineering*. 44, pp. 33–45.
- Zijssling, D.H. (1987). Single Cutter Testing—A Key for PDC Bit Development,” paper SPE 16529/1, Presented at the 1987 Offshore Europe Conference, Aberdeen, 8–11 September.

# 3

## Problems Related to the Mud System

### 3.0 Introduction

The drilling-fluid system is one of the well-construction processes that remains in contact with the wellbore throughout the drilling operation. Advances in mud technology have made it possible to implement a sustainable system for each interval in the well-construction process. As a result, the associated problems have been reduced significantly. Reduction of the cost of the drilling fluid, which is an average of 10% of the total tangible costs of well construction, is a great challenge. Mud performance can affect overall well-construction costs in several ways. In addition, failure to select and formulate the mud correctly will create many problems. This chapter addresses the problems related to drilling-fluid system and proposes the solutions. However, there are some problems which are not directly related to the mud system. These problems are discussed in another chapter. An identified problem well caused by drilling-fluid can be considered as partially solved. Therefore, identifying any problem turns out to be a crucial task. The logical relationship of cause and effect must be well organized to

the identified related problems. Mixing their logical relationship may lead to hindering further problem analysis tasks.

### **3.1 Drilling Fluids and its Problems with Solutions**

A correctly formulated and well-maintained drilling system can contribute to cost containment throughout the drilling operation by enhancing the rate of penetration (ROP), protecting the reservoir from unnecessary damage, minimizing the potential for loss of circulation, stabilizing the wellbore during static intervals, and helping the operator remain in compliance with environmental and safety regulations. Drilling fluids can be reused from well to well, thereby reducing waste volumes and costs incurred for building new mud. Although currently reusing doesn't diminish costs at any appreciable manner, as more operators practice this recycling, the economics of recycling will improve. In addition, the introduction of environment-friendly additives is amenable to recycling and minimization of environmental footprints. To the extent possible, the drilling-fluid system should help preserve the productive potential of the hydrocarbon-bearing zone(s). Minimizing fluid and solids invasion into the zones of interest is critical to achieving desired productivity rates. The drilling fluid also should comply with established health, safety, and environmental (HSE) requirements so that personnel are not endangered and environmentally sensitive areas are protected from contamination. Drilling-fluid companies work closely with oil-and-gas operating companies to attain these mutual goals.

Drilling fluid (also called drilling mud) is an essential part in the rotary drilling system. Most of the problems encountered during the drilling of a well are directly or indirectly related to the mud. To some extent, the successful completions of a hydrocarbon well and its cost depend on the properties of the drilling fluid. The cost of the drilling mud itself is not very high. However, the cost increases abruptly for the right choice, and to keep proper quantity and quality of fluid during the drilling operations. The correct selection, properties and quality of mud is directly related to some of the most common drilling problems such as rate of penetration, caving shale, stuck pipe and loss circulation, and others. In addition, the mud affects the formation integrity and subsequent production efficiency of the well. More importantly, some toxic materials are used to improve the specific quality of the drilling fluid that are a major concern to the environment. Among others, this addition of toxic materials contaminates the underground system as well as the surface of the earth. Economically, it



also translates into long-term liability as stricter regulations are put in place with increasing awareness of environmental impacts of toxic chemicals.

Therefore, the selection of a suitable drilling fluid and routine control of its properties are the concern of the drilling operators. The drilling and production personnel do not need detailed knowledge of drilling fluids. However, they should understand the basic principles governing their behavior, and the relation of these principles to drilling and production performance. They should have a clear vision of the objectives of any mud program, which are: (i) allow the target depth to be reached, (ii) minimize well costs, and (iii) maximize production from the pay zone. In a mud program, factors needing to be considered are the location of well, expected lithology, equipment required, and mud properties. Hence this chapter refers to the author's textbook *Fundamentals of Sustainable Drilling Engineering* for details in the basic components of mud, its functions, different measuring techniques, mud design and calculations, the updated knowledge in the development of drilling fluid and future trend of the drilling fluid. It is important because acquiring this knowledge will lead to an understanding of the real causes, and solutions related to drilling-fluid system.

### 3.1.1 Lost Circulation

During drilling of hydrocarbon wells, drilling fluids are circulated through the drill bit into the wellbore for removal of drill cuttings from the wellbore. The fluids also maintain a predetermined hydrostatic pressure to balance the formation pressure. The same drilling fluid is usually reconditioned and reused. When comparatively low-pressure subterranean zones are encountered during a drilling operation, the hydrostatic pressure is compromised because of leakage into the zones (Figure 3.1). This phenomenon is commonly known as “lost circulation.” So, lost circulation is defined as the uncontrolled flow of mud into a “thief zone” and presents one of the major risks associated with drilling. However, different authorities and researchers defined the lost circulation in a diversified manner. According to oilfield glossary it is defined as “the collective term for substances added to drilling fluids when drilling fluids are being lost to the formations downhole”. Howard (1951) defined it as follows: “loss of circulation is the uncontrolled flow of whole mud into a formation, sometimes referred to as a “thief zone.” It is also defined as “the reduced or total absence of fluid flow up the annulus when fluid is pumped through the drillstring (Schlumberger, 2010). The complete prevention of lost circulation is impossible. However, limiting circulation loss is possible if certain precautions are taken. Failure to control lost circulation can greatly

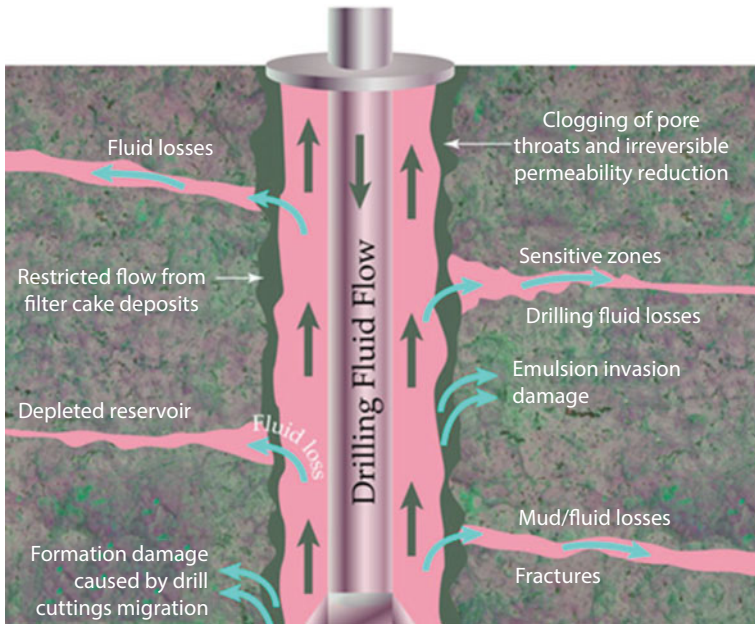

**Figure 3.1** Lost-circulation zones.

increase the cost of drilling, as well as the risk of well loss. Moreover, lost circulation may lead to loss of well control, resulting in potential damage to the environment, fire and/or harm to personnel. The risk of drilling a well in areas known to contain potential zones of lost circulation is a key factor in planning to approve or cancel a drilling project. The successful management of lost circulation should include identification of potential “thief zones”, optimization of drilling hydraulics, and remedial measures when lost circulation occurs.

The problem of lost circulation was apparent in the early history of the drilling industry and was magnified considerably when operators began drilling deeper and/or depleted formations. The industry spends millions of dollars a year to combat lost circulation and the detrimental effects it propagates, such as loss of rig time, stuck pipe, blowouts, and frequently, the abandonment of expensive wells. Moreover, lost circulation has even been cited as the cause for production loss and failure to secure production tests and samples. On the other hand, controlling lost circulation can lead to plugging of production zones, resulting in decreased productivity. The control and prevention of lost circulation of drilling fluids is a problem frequently encountered during the drilling of oil and gas wells. During the drilling of wells, fractures that are created or widened by drilling fluid

pressure are suspected of being a frequent cause of lost circulation. Of course, natural fractures, fissures, and vugs can create lost circulation even during underbalance drilling, in which fluid pressure doesn't play a role in lost circulation.

There are four types of formation and/or zones that can cause loss of circulation: (i) cavernous or vugular formations, (ii) unconsolidated zones, (iii) high permeability zones, and (iv) naturally or artificially fractured formations. Circulation loss can take place when a comparatively high pressure zone (subterranean) is encountered, causing cross flows or underground blowouts. Whenever the loss of circulation crops up, it is noticed by the loss of mud, and the loss zones are classified according to the severity of the loss: (i) "Seepage" with less than 10 bbl/hour loss, (ii) "Partial Loss" for 10 to 500 bbl/hour loss, (iii) "Complete Loss" for greater than 500 bbl/hour loss. The lost circulation problem requires corrective steps by introducing lost circulation materials (LCM) into the wellbore to close the lost circulation zones. Many kinds of materials can be used as LCM. They include low-cost waste products from the food processing or chemical manufacturing industries. Figure 3.1 shows some examples of LCM as listed here.

Historically, mud losses have been dealt with by dumping some mica or nut hulls down a wellbore. There are numerous reports of 'throwing in everything available' to stop the extreme cases of mud loss. However, as the drilling operation becomes increasingly sophisticated and great feats are achieved in terms of drilling in difficult terrains and deep wells, simplistic solutions are no longer applicable. The industry is accelerating its activities in deepwater and depleted zones, both of which present narrow operating limits, young sedimentary formations, and high degree of depletion overbalanced drilling. These newfound prevailing conditions are susceptible to creating fractures and thus lead to lost circulation. Among others, drilling through and below salt formations presents a host of technical challenges as well. The thief zone at the base of the salt can introduce severe lost circulation and well control problems. This often results in loss of the interval or the entire well. The lost time treating severe subsalt losses can last for several weeks, with obvious cost implications, especially for deepwater drilling operations. Salt formations are common for oil-bearing formations that can be termed pre-salt if older or subsalt if younger. The oil-bearing formations of below salt in the Gulf of Mexico are mainly subsalt, whereas those in offshore Brazil are a mix of subsalt and pre-salt. The difficulty in managing a drilling operation through a salt formation lies in the fact the salt composition varies greatly. For instance, for the Gulf of Mexico, the salt formation contains mainly NaCl. On the other hand, the offshore Brazil salt formations have predominantly  $MgCl_2$ , which is

far more reactive than NaCl. Salt formations are typical of other formations that are equally plastic and mobile can also be encountered during drilling. Controlling losses in this zone has proven to be extremely difficult as it involves matching the composition of the mud with that expected downhole, in order to minimize leaching of the in-situ salt into the drilling mud – a process that would create imbalance in the fluid system. Also, the plasticity of the salt may cause shifting. Therefore, the mud weight should be as close to overburden gradient, otherwise salt may shift into wellbore, leading to pipe being stuck. Very few lost circulation remedies have been successful, especially when using invert emulsion drilling fluids. Typically, a salt formation should be drilled with salt-tolerant water-based drilling fluids or with invert emulsion fluids. Deeper salt zones can be drilled with oil-based fluids that can be replaced with water-based mud after the salt formation has been passed. Such formations are available in the Bakken basin of the United States. In drilling through salt formations, considerations of density, salinity, and rheology are of paramount importance. The density consideration relates to maintaining bore stability. The salinity relates to preventing leaching from the salt formation as well as preventing intrusion and salt deposition in the wellbore. The rheology consideration relates to cleaning the salt cuttings and keeping them afloat during the return of the mud.

When dealing with induced fractures the problem is even more complicated because the shape and structure of induced formation fractures are always subject to the nature of the formation, drilling and mechanical effects, as well as geological influences over time. When the overbalance pressure exceeds the fracture pressure, a fracture may be induced and lost circulation may occur. By incorporating a lost circulation material (LCM) in the fracture to temporarily plug the fracture, the compressive tangential stress in the near-wellbore region of the subterranean formation increases, resulting in an increase in the fracture pressure, which in turn allows the mud weight to operate below the fracture pressure.

LCM are often used as a background treatment or introduced as a concentrated “pill” to stop or reduce fluid losses. The main objective when designing an effective treatment is to ensure that it is able to seal fractures effectively and stop losses at differential pressure. The differential pressure is caused by the elevated drilling fluid pressures compared to the pore fluid pressure in regular drilling operations or drilling fluid pressures exceeding the wellbore fracture pressure. The design of the LCM treatment hinges upon particle size distribution (PSD) as the most important parameter (Ghalambor *et al.*, 2014; Savari *et al.*, 2015). Al Saba *et al.*, 2017) compared various PSD methods and proposed one that is the most accurate. Table 3.1

**Table 3.1** PSD Selection criteria (Al Saba *et al.*, 2017).

Method	PSD selection criteria	Percentage match with lab data
Abrams' Rule (Abrams, 1977)	$D_{50} \geq 1/3$ the formation average pore size	68%
D90 Rule (Smith <i>et al.</i> , 1996; Hands <i>et al.</i> , 1998)	D90 = the formation pore size	77%
Vickers' Method (Vickers <i>et al.</i> , 2006)	D90=largest pore throat D75 < 2/3 the largest pore throat D50 $\geq 1/3$ D25= 1/7 the mean pore throat D10 > the smallest pore throat	45%
Halliburton Method (Whitfall, 2008)	D50 = fracture width	55%
Al Saba <i>et al.</i> (2017)	$D_{50} \geq 3/10$ fracture width $D_{90} \geq 1/3$	90%

lists these methods. The most recent selection criteria are the most accurate and they stipulate that D50 and D90 should be equal or greater than 3/10th and 6/5th of the fracture width, respectively. Al Saba *et al.* (2017) reported that nutshells can plug fractures with relatively low concentrations whereas graphite and calcium carbonate are effective only at higher concentrations.

In general, there is a general fascination for sphericity and roundness of LCM, needs to be taken into consideration when analyzing PSD. As such, artificial LCM have gained popularity.

Recent advances in LCM have been in developing an array of materials with a range of sizes, shapes, and specific gravities. The new generation of these materials involve smart materials, such as the one patented by Halliburton (Rowe *et al.*, 2016). Rowe *et al.* introduced Micro-electro-mechanical systems lost circulation materials (MEMS-LCM). A typical usage of this technology would involve drilling at least a portion of a wellbore penetrating the formation with a drilling fluid that comprises a base fluid. This can be followed by several cycles of MEMS-LCM, and another set of LCM, wherein the MEMS-LCM and the LCM are substantially similar in size, shape, and specific gravity. After this cycle, measurements can be made to determine concentrations of the MEMS-LCM in the drilling fluid before circulating the drilling fluid through the wellbore and after the MEMS-LCM treatment, thus finalizing the concentration of the next phase of MEMS-LCM.

One condition of paramount importance in sealing induced fractures (i.e., to change shape and size as per wellbore pressure changes) is having the LCM reaching the tip of the fracture. Related to the breathing tendency of induced fractures (manifested through pressure pulsation), pressure buffering is another condition that should be fulfilled for effective sealing. Preferably, to stop the breathing tendency in a robust manner, the pills should be able to increase the fracture gradient at a level sufficiently high to avoid reopening the fracture during the subsequent drilling phases. Table 3.2 shows several LCM with their characteristic concentrations.

Figure 3.2 shows partial (Figure 3.2a) and total lost-circulation zones (Figures 3.2b, and c). In partial lost circulation, mud continues to flow to surface with some loss to the formation. Total lost circulation, however, occurs when all the mud flows into a formation with no return to surface.

**Table 3.2** Lists of LCMs.

LCM - 65 PPB	
CaCo <sub>3</sub> F - M	5 ppb
NUT PLUG	8 ppb
BAROFIBER M	5 ppb
FRACSEAL C	10 ppb
LC LUBE	5 ppb
FRACSEAL M	10 ppb
MIICA F	10 ppb
MIICA M	6 ppb
N-SEAL	4 ppb

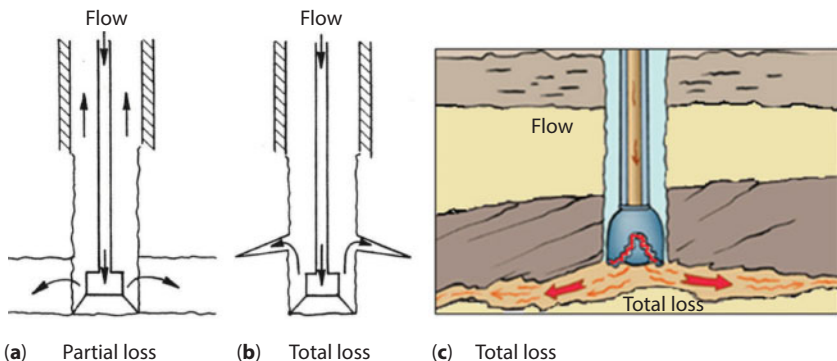

**Figure 3.2** Lost-circulation zones showing partial and total loss.

A series of lost circulation decision trees is developed to address lost circulation problems for the deepwater prospect (Figure 3.3).

In general, there are three types of basic agents used in the petroleum industry to control the loss of circulation problem. These are: (i) bridging agents, (ii) gelling agents, and (iii) cementing agents. These agents are either employed individually or in a blended combination. The bridging agents are the ones that plug the pore throats, vugs, and fractures in formations. Examples of such agents are ground peanut shells, walnut shells, cottonseed hulls, mica, cellophane, calcium carbonate, plant fibers, swellable clays ground rubber, and polymeric materials. Bridging agents are further classified based on their morphology and these can be: (i) flaky (e.g., mica flakes and pieces of plastic or cellophane sheeting), (ii) granular (e.g., ground and sized limestone or marble, wood, nut hulls, Formica, corncobs

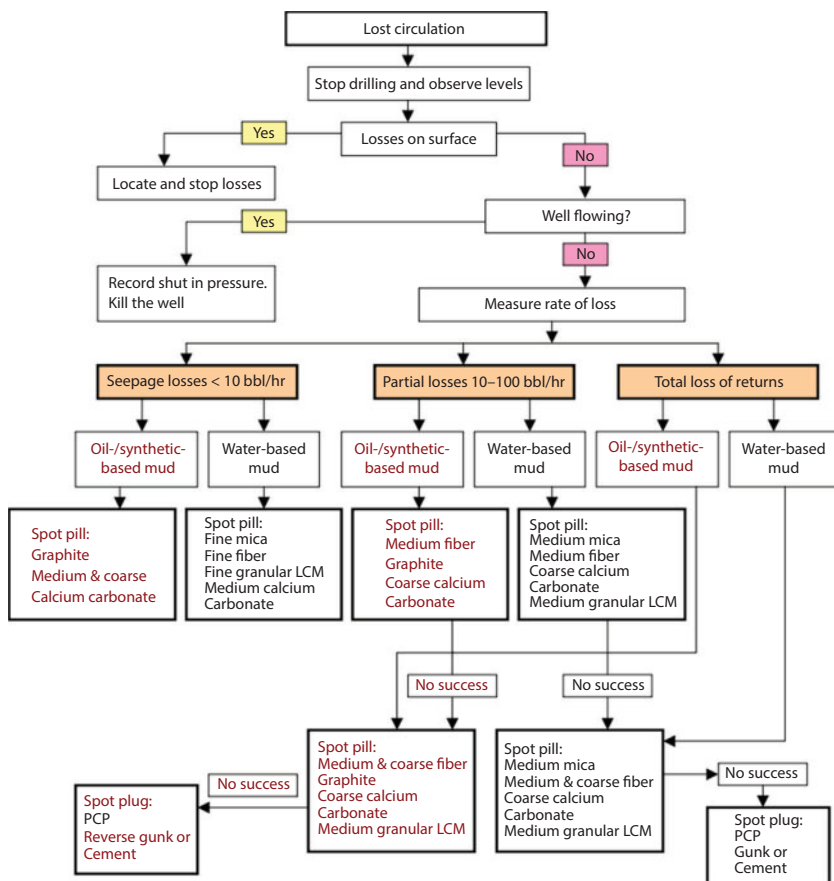

Figure 3.3 Lost Circulation Treatment Decision Tree.

and cotton hulls), and (iii) fibrous (e.g., cedar bark, shredded cane stalks, mineral fiber and hair). Gelling agents and cementing agents are used for transportation and placement of the bridging agent at the appropriate place in the circulation loss zone. Highly water absorbent cross-linked polymers are also used for loss of circulation problem, as they form a spongy mass when exposed to water.

The LCM are evaluated based on their sealing properties at low and high differential pressure conditions. In addition, effectiveness of the sealing to withstand all kind of pressures during drilling is tested. LCM are classified according to their properties and application, such as formation bridging LCM and seepage loss LCM. Often more than one LCM type may have to be used to eliminate the lost circulation problem.

These drilling problems are encountered both in onshore and offshore fields when the formation is weak, fractured and/or unconsolidated. Drilling for oil and gas in deep water encounters further challenges, brought about by a host of reasons. Some potential hazards are shallow water flow (SWF), gas kicks and blowouts, presence of unconsolidated sand formations, shallow gas, gas hydrate lost circulation, sea floor washout, borehole erosion, etc. These problems are not only hazards on their own; they can also cause a significant increase in the total drilling cost. Consequently, alleviation of the scope and capacity of these hazards and challenges is imperative for safe and economic completion of deep water wells, so that work can be done systematically with the least amount of risk.

### *3.1.1.1 Mechanics of Lost Circulation*

Lost circulation frequently occurs in cavernous limestone or in gavel beds at relatively shallow depths and under normal pressure conditions. In this type of lost circulation, the mud will flow into the cavities at any pressure more than the formation fluid pressure without disturbing the reservoir rock. This type of lost circulation is prevalent in the cap rock of pier cement-type salt domes. Lost circulation under these conditions is essentially a filtration problem which can be corrected if the large pore spaces can be plugged.

However, the lost circulation due to abnormal pressures differs in mechanism from the foregoing one. In this case, mud fluid is not lost by filtration into large pore spaces in the reservoir rock. The loss of whole mud can take place only through formations in which the pore sizes are so large as to cause the concept of permeability to lose its generally accepted meaning. Lost circulation occurs only when the mud weight is approaching the weight of the overburden (15 to 18 lbs per gallon). Loss of circulation in this case results from tensile failure of the sediments along lines of weakness, rather



than from mud filtration into existing pore spaces. That formation failure does occur as evidenced by the conditions under which circulation is lost. The usual condition is a sudden and complete loss of returns which may occur while drilling, circulating, or while out of the hole to run an electrical survey. There are several situations that can result in lost circulation such as (i) formations that are inherently fractured, (ii) cavernous (i.e., hollow) formation, (iii) highly permeable zone, (iv) improper drilling conditions, (v) induced fractures caused by excessive downhole pressures and setting intermediate casing too high, (vi) improper annular hole cleaning, (vii) excessive mud weight, and (viii) shutting in a well in high-pressure shallow gas.

Induced or inherent fractures or fissures may appear as horizontal at shallow depth or vertical at depths greater than approximately 762 m. Excessive wellbore pressures are developed due to high flow rates (i.e., high annular-friction pressure loss) or tripping in too fast (i.e., high surge pressure). This can lead to mud equivalent circulating density (ECD). Induced fractures can also be caused by improper annular hole cleaning, excessive mud weight, and shutting in a well in high-pressure shallow gas. Equations (3.1) and (3.2) show the conditions that must be maintained to avoid fracturing the formation during drilling, and tripping in, respectively.

$$\Psi_{eq} = \Psi_{smw} + \Delta\Psi_{afp}, \text{ which should be } < \Psi_{ffg} \tag{3.1}$$

$$\Psi_{eq} = \Psi_{smw} + \Delta\Psi_{asp}, \text{ which should be } < \Psi_{ffg} \tag{3.2}$$

Here

- $\Psi_{eq}$  = equivalent circulating density of mud
- $\Psi_{smw}$  = static mud weight
- $\Psi_{ffg}$  = formation-pressure fracture gradient in equivalent mud weight
- $\Delta\Psi_{afp}$  = additional mud weight caused by friction pressure loss in annulus
- $\Delta\Psi_{asp}$  = additional mud caused by surge pressure

Cavernous formations are often limestones with large caverns. This type of lost circulation is quick, total, and the most difficult to seal. High-permeability formations are potential lost-circulation zones, which are shallow sand with permeability greater than 10 Darcies. In general, deep sand has low permeability and presents no loss circulation problems. The level of mud tanks decreases gradually in non-cavernous thief zones. In such situations, if drilling continues, total loss of circulation may occur.

Partial loss of returns is common in the case of mud loss by filtration. However, this is a rare occurrence under abnormal pressure conditions. The mechanics of lost circulation of this type are probably most closely duplicated in nature by igneous intrusions. In both cases, the formation falls under extreme pressure. The only difference is in the source of the pressure.

### 3.1.1.2 Preventive Measures

The complete prevention of lost circulation is impossible because some formations, such as inherently fractured, cavernous, or high-permeability zones, are not avoidable when encountered during the drilling operation if the target zone is to be reached. However, limiting circulation loss is possible if certain precautions are taken, especially those related to induced fractures. There are some preventive measures that can reduce the lost circulation which can be listed as: (i) crew education, (ii) good mud program i.e., maintain proper mud weight, (iii) minimize annular friction pressure losses during drilling and tripping in, (iv) maintain adequate hole cleaning and avoid restrictions in the annular space, (v) set casing to protect weaker formations within a transition zone, (vi) updating formation pore pressure and fracture gradients for better accuracy with log and drilling data, and (vii) study wells in area to be drilled. The rule of thumb is that if anticipated, treat mud with LCM.

If loss of circulation happens, there are some actions that need to be followed: (i) pump lost circulation materials in the mud, (ii) seal the zone with cement or other blockers, (iii) set casing, (iv) dry drill (i.e., clear water), and (v) updating formation pore pressure and fracture gradients for better accuracy with log and drilling data. Now, once lost-circulation zones are anticipated, preventive measures should be taken by treating the mud with LCM and preventive tests such as the leak off test and formation integrity test should be performed to limit the possibility of loss of circulation.

**Leak-off test (LOT):** Conducting an accurate leak off test is fundamental to prevent lost circulation. The LOT is performed by closing in the well, and pressuring up in the open hole immediately below the last string of casing before drilling ahead in the next interval. Based on the point at which the pressure drops off, the test indicates the strength of the wellbore at the casing seat, typically considered one of the weakest points in any interval. However, extending a LOT to the fracture-extension stage can seriously lower the maximum mud weight that may be used to safely drill the interval without lost circulation. Consequently,

stopping the test as early as possible after the pressure plot starts to break over is preferred.

During the LOT, the leak-off test pressure, and equivalent mud weight at shoe can be calculated using the following equations.

$$LOT_p = 0.052 \times MW_{LT} \times D_{T-shoe} + P_{a-LOT} \quad (3.3)$$

$$EMW_{LOT} = \frac{LOT_p}{0.052 \times D_{T-shoe}} \quad (3.4)$$

Here

- $LOT_p$  = leak-off test pressure, psi
- $MW_{LT}$  = leak-off test mud weight, ppg
- $D_{T-shoe}$  = total vertical depth at shoe, ft
- $P_{a-LOT}$  = applied pressure to leak-off, psi
- $EMW_{LOT}$  = equivalent mud weight at shoe, ppg

**Formation integrity test (FIT):** To avoid breaking down the formation, many operators perform a FIT at the casing seat to determine whether the wellbore will tolerate the maximum mud weight anticipated while drilling the interval. If the casing seat holds pressure that is equivalent to the prescribed mud density, the test is considered successful and drilling resumes.

When an operator chooses to perform an LOT or an FIT, if the test fails, some remediation effort such as a cement squeeze should be carried out before drilling resumes to ensure that the wellbore is competent.

During the FIT, the formation integrity test pressure, and equivalent mud weight at shoe can be calculated using the following equations.

$$FIT_p = 0.052 \times MW_{FIT} \times D_{T-shoe} + P_{a-FIT} \quad (3.5)$$

$$EMW_{FIT} = \frac{FIT_p}{0.052 \times D_{T-shoe}} \quad (3.6)$$

Here

- $FIT_p$  = formation integrity test pressure, psi
- $MW_{FIT}$  = formation integrity test mud weight, ppg
- $P_{a-FIT}$  = applied formation integrity pressure, psi
- $EMW_{FIT}$  = equivalent mud weight at shoe, ppg

### 3.1.1.3 Mud Loss Calculation

The length of the annulus or the length of the low-density fluid and mud density of the lost circulation can be calculated based on annulus capacity behind the drill collar. If the lost circulation volume is smaller than the annulus volume against the drillpipe, the length of the annulus (i.e., loss height) can be expressed in terms of the volume of the low-density fluid pumped to balance the formation pressure, and annulus capacity. Mathematically,

If  $V_l < V_{an\_dp}$ , the length of the low-density fluid required in order to balance the formation pressure is given by:

$$L_l = \frac{V_l}{C_{an\_dc}} \quad (3.7)$$

where,

- $C_{an\_dc}$  = annulus capacity behind the drill collar, bbl/ft
- $L_l$  = length of the annulus or the length of the low-density fluid, bbl
- $V_l$  = volume of the low-density fluid pumped to balance the formation pressure, bbl
- $V_{an\_dp}$  = the annulus volume against drillpipe, bbl

If  $V_l > V_{an\_dp}$ , the length of the length of the low-density fluid required in order to balance the formation pressure is given by:

$$L_l = L_{dc} + \frac{V_l - V_{an\_dc}}{C_{an\_dp}} \quad (3.8)$$

where,

- $C_{an\_dc}$  = annulus capacity behind the drillpipe, bbl/ft
- $L_{dc}$  = length of drill collar, ft
- $V_{an\_dc}$  = the annulus volume against drill collar, bbl

Formation pressure is given by

$$P_{ff} = 0.052\{D_w \times \rho_w + (D_v - D_w)\rho_m\} \quad (3.9)$$

where,

- $D_v$  = vertical depth of the well where loss occurred, ft
- $D_w$  = vertical depth of water, ft
- $P_{ff}$  = formation pressure, psi
- $\rho_m$  = mud density, ppg
- $\rho_w$  = seawater density, ppg

In addition, improper annular hole cleaning, excessive mud weight, or shutting in a well in high-pressure shallow gas can induce fractures, which can cause lost circulation. Equations (3.7) and (3.8) show the conditions that must be maintained to avoid fracturing the formation during drilling and tripping in, respectively. However, Eq. (3.10) needs to be satisfied also to avoid the fracture.

$$\rho_{eq} = (\rho_{mh} + \Delta\rho_s) < \rho_{frac} \tag{3.10}$$

where,

- $\rho_{eq}$  = equivalent circulating density of mud, ppg
- $\rho_{mh}$  = static mud weight, ppg
- $\rho_{frac}$  = formation pressure fracture gradient in equivalent mud weight, ppg
- $\Delta\rho_s$  = additional mud caused by surge pressure, ppg

**Example 3.1:** While drilling an 8 ½ in hole at 17,523 ft (TVD) with a mud density of 11 ppg, the well encountered a big limestone cavern. Therefore, there was mud loss. Drilling was stopped, and the annulus was filled with 58 bbls of 8.4 ppg water until the well was stabilized. Calculate the formation pressure and the density that should be used to drill through the zone. The previous 9 5/8 in casing was set at 15,500 ft.; the drilling consists of 900 ft of 6 in drill collar and 5 in drillpipe. Use the capacity of the casing annulus against the drillpipe to be 0.05149 bbl/ft.

**Solution:**

**Given data**

- $D_h$  = hole diameter = 8.5 in
- $D_v$  = total vertical depth = 17,523 ft
- $\rho_m$  = mud density = 11 ppg
- $V_l$  = the volume of water pumped to balance the formation pressure = 58 bbl
- $\rho_w$  = seawater density = 8.4 ppg
- $D_c$  = casing diameter = 9.625 in
- TVD<sub>C</sub> = total casing depth = 15,500 ft
- $L_{dc}$  = length of the drill collar = 900 ft
- $D_{dc}$  = drill collar diameter = 6.0 in
- $D_{dp}$  = drillpipe diameter = 5.0 in
- $C_{an-dp}$  = the capacity of the casing annulus against the drillpipe = 0.05149 bbl/ft

**Required data** $P_{ff}$  = formation pressure, psi $\rho_{eq}$  = equivalent circulating density of mud, ppg

The volume of the casing annulus against drillpipe is

$$V_{an\_dp} = 0.05149 \times 15,500 = 798.0 \text{ bbl}$$

If  $V_l < V_{an\_dp}$ , the length of the annulus when balanced is given by Eq. (3.7):

$$L_l = \frac{V_l}{C_{an\_dp}} = \frac{58 \text{ bbl}}{0.05149 \text{ bbl/ft}} = 1,126.43 \text{ ft}$$

Using Eq. (3.9), the formation pressure can be calculated as:

$$P_{ff} = 0.052\{D_w \times \rho_w + (D_v - D_w)\rho_m\}$$

$$P_{ff} = 0.052\{1,127 \times 8.4 + (17,523 - 1,127)11\}$$

$$P_{ff} = 9,870.8 \text{ psi}$$

The equivalent mud weight can be calculated as:

$$\rho_{eq} = \frac{P_{ff}}{0.052 \times D_v} = \frac{9,870.8 \text{ psi}}{0.052 \times 17,523 \text{ ft}} = 10.83 \text{ ppg}$$

**3.1.1.4 Case Studies**

Nasiri *et al.* (2017) reported a series of field tests in various oil and gas fields of Iran. They evaluated the productivity of various LCM in bentonite mud – the mud that is most commonly used in Iranian petroleum fields. The following operation was reported.

1. After recognizing heavy loss phenomenon, the bit was pulled up to the depth of 1314 m.
2. Mud was injected into the well discontinuously in preparation of cement.

3. Then the bit was transferred to the depth of 1611 m. In this depth first, 8 barrels of water and then, 50 barrels of 95 PCF class G cement were pumped into the well and formation, respectively.
4. In the next phase, after pumping 1 barrel of water, cement plug was inserted with 94 barrels of drilling mud. No fluid was received at the surface.
5. At next phase, after allocating enough time for thickening of cement, cementation process was repeated in depth of 1611 m, with similar conditions with the first phase.
6. After pumping 40 barrels of cement, mud returned to the surface.
7. After allocating enough time for setting of cement, drilling was restarted. Cement was drilled to the depth of 1556 m. Again the mud loss was determined to be 40 bph.
8. In this phase, 100 barrels of RIPI-LQ bentonite pill were injected to the well. The mud loss rate reduced to 1 bph. Drilling was continued to the depth of 1636 m.
9. Drilling continued to 1686 m depth. In this process, heavy losses occurred at depths of 1671, 1670, 1673, 1678, 1679, 1679.5, and 1686 m, and they were stopped by overall pumping of 350 barrels of RIPI-LQ bentonite pill.
10. Heavy loss occurred between the depths of 1722–1724 m, and no mud return observed. It should be mentioned that based on what geologists claim, the top of Fahliyan formation has a depth of 1722 m. This time by pumping 100 barrels of RIPI-LQ bentonite pill, the mud loss reduced significantly and mud return was observed.
11. Drilling was continued to the depth of 1756 m, with loss between 1 and 5 barrels per hour. Then, 50 barrels of high viscosity bentonite mud were injected to the well to clean it up. At the next step, the bit was pulled up to the depth of 1550 m and the mud was replaced by a 60 PCF light mud. At first, 350 barrels of light mud had been injected to the well to displace the previous mud. Then the bit was pulled up to the depth of 1520 m, and again 550 barrels of light mud were injected to the well.
12. On Day 5, after lightening the mud, heavy loss occurred at the depth of 1756 m and no mud return was observed in the outlet. Then, 100 barrels of RIPI-LQ bentonite pill was pumped into the well and finally, the mud loss was reduced significantly until 1 to 2 barrels per hour.

Of interest is the fact, the following figures (Figure 3.4, and Figure 3.5) were generated in the laboratory in order to determine concentration of the LCM.

The laboratory tests indicated that that Mica and coarse Oyster Shell cannot adequately control the mud loss. On the other hand, Quick Seal and RIPI-LQC materials also have difficulties in controlling heavy losses (in 0.2 inches fractures). So, to control heavy losses, mixtures of Quick Seal and RIPI-LQC, and mixtures of RIPI-LQC and RIPI-LQF were used. The experiments' results showed that the least amount of loss

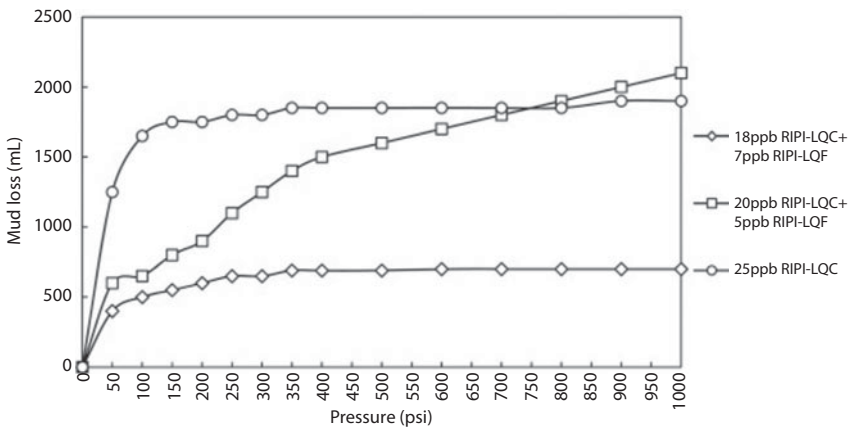

Figure 3.4 Mud loss for different LCM (RIPI-LQC).

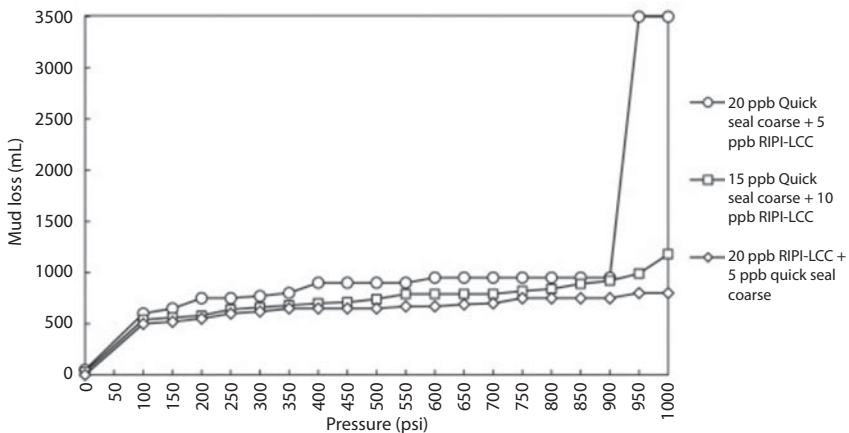

Figure 3.5 Mud loss for different LCM (RIPI-LCC).



occurred by using RIPI-LQC and Quick Seal mixture with 20 and 5 ppb concentration, respectively, and also RIPI-LQC and RIPI-LQF mixture with 18 and 7 ppb concentration, respectively. For more accurate investigations, the amounts of fluid loss, sealing pressure, and reverse pressure of these mixtures were compared with each other. Results showed that RIPI-LQC and RIPI-LQF mixture has a better performance and damages the drilled formation less. Field test data confirmed the applicability of this new additive to control partial and complete losses. Of significance is the conclusion that a field operation relied heavily on laboratory research prior to successfully remedying a pressing drilling operational problem.

### 3.1.2 Loss of Rig Time

The loss of rig time is an integrated part of non-productive time (NPT) during drilling and completion. The estimation of drilling and completion time is a dependent variable which is governed by different activities while drilling. Loss of rig time is part of the whole drilling and completion time. Well drilling time is estimated based on rig-up and rig-down time, drilling time, trip time, casing placement time, formation evaluation and borehole survey time, completion time, non-productive time, and trouble time. Drilling times include making hole, including circulation, wiper trips and tripping, directional work, geological sidetrack and hole opening. Flat times are spent on running and cementing casing, making up BOPS and wellheads. The well needs to be tested while drilling so it includes testing and completion time. The formation evaluation time includes coring, logging, etc. Trouble time includes time spent on hole problems such as stuck pipe, well-control operations, loss circulation, and formation fracture. Major time expenditures always are required for drilling and tripping operations. In addition to predicting the time requirements for drilling and tripping operations, time requirement for other planned drilling operations also must be estimated. The additional drilling operations usually can be broken into the general categories of wellsite preparation, rig movement and rigging up, formation evaluation and borehole surveys, casing placement, well completion, and drilling problems. So, the time estimate should consider i) initial placement, ii) ROP in offset wells from where the total drilling time for each section may be determined, iii) flat times for running and cementing casing, iv) flat times for nipping up/down BOPs and nipping up wellheads, v) circulation times, and vi) BHA makes up times. However, all these factors are very much dependent on rig side people's

experience, efficiency, and available resources. So well drilling time estimation is a challenge for the drilling engineer.

In well drilling time estimation, a second major component of the time required to drill a well is the trip time which can be defined as the time required changing a bit and resuming drilling operations. The time required for tripping operations depends primarily on the depth of the well, the rig being used, and the drilling practices followed. It can be approximated using the following relation as

$$t_t = 2 \left( \frac{\bar{t}_s}{\bar{l}_s} \right) \bar{D}_t \quad (3.11)$$

Here

- $t_t$  = trip time required to change a bit and resume drilling operations, hrs
- $\bar{t}_s$  = the average time required to handle one stand of drillstring, hrs
- $\bar{l}_s$  = the average length of one stand of drillstring, ft
- $\bar{D}_t$  = the mean depth where the trip was made (i.e., mean depth at the trip level), ft

It is noted that the time required to handle the drill collars is greater than for the rest of the drillstring, but this difference usually does not warrant the use of an additional term in Eq. (3.11). Historical data for the rig of interest are needed to determine,  $\bar{t}_s$ .

### 3.1.3 Abandonment of Expensive Wells

An abandonment well is defined as “a well which is plugged in or suspended permanently due to some technical reasons in the drilling process or on which operations have been discontinued”. Further, if a well is reached in its economic limit, the well is declared as abandonment well. Once the well becomes abandoned, the tubing is detached and sections of the wellbore are filled with concrete. This filling process is required to restrict the flow path of the formation fluid from the surface, and inter-communication between the wells. If there is no change of market supply and demand, and/or oil-price increasing trend, the well is plugged as a permanent abandonment.

There are many reasons to abandon the wells such as: (i) if after drilling a mile or more the well encounter sandy formations filled with a brine, and mixed with radioactive, heavy metals and other toxins, (ii) if there is a

possibility of brine to be contaminated, and seep into fresh water aquifers or sometimes reach the surface, (iii) if the well reaches its economic limit, (iv) if there is a possibility of having kick, and (v) the well is no longer needed to support oil and gas development or because an operator's mineral lease has expired.

In general, there are set strict requirements by the government, and different environmental agencies for the protection of environment and public safety in the localities of abandonment wells. To ensure the safe and effective abandonment of oil and gas wells, all operators must follow some procedures such as: (i) identification and creation of a project plan, (ii) execution and implementation, (iii) finalization for surface abandonment, etc.

### **3.1.4 Minimized Production**

The hydrocarbon production from an underground reservoir includes mechanical, chemical, electrical, and geological processes. These processes have significant roles in the formation, and the wellbore flow. Many of these practices can eventually cause a problem with the well, formation, and the surface facilities. These problems ultimately end up with either a decrease in production or a failure of equipment installed downhole or at the surface. Most of the serious problems can be avoided or delayed through preventive maintenance techniques. It can also be tackled by early recognition through a routine analysis of production rates, fluids type and rheology (i.e., PVT analysis), and by inspecting the mechanical condition of the well. Such practices can prevent a costly workover operation. It may also avoid total loss of the wellbore.

### **3.1.5 Mud Contamination**

Mud contamination is directly related to the drilling mud. In geotechnical engineering, drilling fluid is defined as a fluid used to drill boreholes into the earth. This fluid is used while drilling oil and gas wells and on exploration drilling rigs. Drilling fluids are also used for much simpler boreholes, such as water wells. There are three main categories of drilling fluids: (i) water-based muds (which can be dispersed and non-dispersed), (ii) non-aqueous muds (which is usually called oil-based mud, and (iii) gaseous drilling fluid (in which a wide range of gases can be used). The primary functions of the drilling fluid are to (Hossain and Al-Majed, 2015): (i) remove and transport cuttings from bottom of the hole to the surface through annulus (i.e., clean the borehole from cuttings and removal of cuttings), (ii) exert sufficient hydrostatic pressures to reduce the probability of having a kick

(i.e., control of formation pressure), (iii) cool and lubricate the rotating drillstring and drilling bit, (iv) transmit hydraulic horsepower to the bit, (v) form a thin, low permeable filter cake to seal and maintain the walls of the borehole and prevent formation damage (i.e., seal the thief zones), (vi) suspend drill cuttings in the event of rig shutdown so that the cuttings do not fall to the bottom of the hole and stick the drillpipe, (vii) support the wall of the borehole, and (viii) maintain wellbore stability (i.e., keep new borehole open until cased).

In addition to the above functions, there are some other secondary functions such as suspending the cuttings in the hole and dropping them in surface disposal areas, improving sample recovery, controlling formation pressures, minimizing drilling fluid losses into the formation, protecting the soil strata of interest (i.e., should not damage formation), facilitating the freedom of movement of the drillstring and casing, and reducing wear and corrosion of the drilling equipment, and provide logging medium. It is noted that the following side effects must be minimized to achieve the above functions (Hossain and Al-Majed, 2015): (i) damage to subsurface formation, especially those that may be productive, (ii) loss of circulation, (iii) wash and circulation pressure problems, (iv) reduction of penetration rate, (v) swelling of the sidewalls of the borehole creating tight spots and/or hole swelling shut, (vi) erosion of the borehole, (vii) attaching of the drillpipe against the walls of the hole, (viii) retention of undesirable solids in the drilling fluid, and (ix) wear on the pump parts.

Mud composition is affected by geographic location, well depth, and rock type. This contamination is altered as rock depth formulations and other conditions change. Drilling fluid maintenance costs can decrease greatly when proper solids control techniques are utilized. Adverse effects caused by drilled cuttings account for a major portion of drilling fluid maintenance expenditures. Drilling fluids are usually formulated to meet certain properties to enable the mud to carry out its basic functions. The importance of selection of a proper mud system which is free from contamination cannot be overemphasized. A poor design and contaminated drilling fluid can be very costly in the life of any well.

A contaminated mud is defined as “when a foreign material enters the mud system and causes undesirable changes in mud properties, such as density, viscosity, and filtration”. While drilling the drilling fluids is exposed to many contaminants, each one has different effects and consequences which lead to necessary treatment to minimize and avoid the drilling problems. Mud contamination can result from overtreatment of the mud system with additives or from minerals/material entering to the mud circulation system during drilling. Contaminated drilling fluids are a

substantial potential hazard to the sensitive marine ecosystem. Therefore, there is a need for an appropriate process to treat the contaminated fluids sufficiently so that purified fluid, and thus unpolluted water can be discharged into the environment by the end of the process. Drilling fluids are the viscous emulsions which are circulated through the drilling pipe during drilling for crude oil to pump the milled product upwards at the same time as the oil. These emulsions rapidly become contaminated with mud, salt water, different minerals of the formation, and oil residues. As a result, drilling fluids should be continuously cleaned to ensure a smooth drilling process. The contaminated fluids become hazardous to the sea too.

### 3.1.5.1 Sources and Remediation of the Contamination

While drilling the mud is exposed to many contaminants; each one has different effects and consequences which lead to necessary treatment to minimize and avoid the drilling problems. The most common contaminants to drilling mud are: (i) solids (added, drilled, active, inert), (ii) calcium and magnesium, (iii) carbonates and bicarbonates, (iv) salts formations and brine flows. The most common contaminants of water-based mud systems are: (i) solids, (ii) Gypsum/anhydrite ( $\text{Ca}^{2+}$ ), (iii) Cement/lime ( $\text{Ca}^{2+}$ ), (iv) Makeup water ( $\text{Ca}^{2+}$  and  $\text{Mg}^{2+}$ ), (v) Soluble bicarbonates and carbonates ( $\text{HCO}_3^-$ , and  $\text{CO}_3^{2-}$ ), (vi) soluble sulfides ( $\text{HS}^-$  and  $\text{S}^{2-}$ ), (vii) salt/saltwater flow ( $\text{Na}^+$ , and  $\text{Cl}^-$ ).

**(i) Solids:** In oilfield terminology solids are classified by their density or specific gravity into two basic categories: (i) High Gravity (HGS) – High gravity solids have  $\text{SG} > 4.2$ . Usually they are used as a weighting agent such as barite and hematite, (ii) Low Gravity (LGS) – Low gravity solids have  $\text{SG} 1.6 - 2.9$ . Usually they are used as commercial bentonite and drilled solids with an assumed  $\text{SG}$  of 2.5.

Source of solids in mud are basically additives and formation. High gravity solids are added to the mud to increase fluid density. Even though they are added deliberately and are essentially non-reactive solids, they still adversely affect fluid rheology, particularly when they degrade by attrition to ultra-fine particles. Low gravity solids are often referred to as drilled solids and are derived from the drilled formation.

The contamination symptoms can easily be traced. In general, drilled solids are the most common contaminant in drilling mud. Any particle of rock that is not removed by the solids removal equipment is recirculated and reduced in size by attrition. This process increases the exposed surface area. More mud is required to wet the surfaces and increased product is

required to maintain the desired fluid parameters. The increase in the number of particles in the mud results in an increase in inter particle action and hence an increase in rheology, particularly plastic viscosity. The irregular shape and size of drilled solids produces poor filter cake quality which in turn tends to result in an increase in filtrate volume and cake thickness.

There are some remedial actions needed to prevent the solid contaminations. Among them, the efficient use of the best available solids removal equipment is essential in preventing a buildup of undesirable drilled solids. These are (i) primary separation (i.e., shale shakers), (ii) hydro-cyclones (i.e., desanders and desilters), (iii) centrifuges (e.g., typically 1–1.5 bbl/min), and (iv) dilution (i.e., increasing the liquid phase of the mud).

**(ii) Calcium and Magnesium:** Calcium or magnesium ions may even at low concentrations contaminate the mud system. They have adverse effects on some water-based mud when these muds have a high solids content. Very high concentrations of either of these ions may have adverse effects on the performance of polymers in water-based mud and on the emulsification packages of some oil-based mud.

Both calcium and magnesium can be present in makeup water (e.g., particularly seawater), formation water and mixed salt evaporite formations. Calcium is encountered in greatest quantity when drilling cement or anhydrite. Magnesium often accumulates in the mud when drilling in magnesium rich shales (e.g., North and Central North Sea) or mixed salt formations (e.g., the Zechstein evaporites of the southern North Sea).

The existence of magnesium and calcium can easily be found through pH. The major effect of magnesium is to react with hydroxyls in the mud system thus depleting mud alkalinity and pH. This can in turn allow the undesirable carbonate and bicarbonate components of alkalinity to become dominant. Calcium ions flocculate bentonite-based muds and other water-based mud containing reactive clays. It gives rise to changes in rheology (i.e., decrease in plastic viscosity and increase in yield point and gels), and loss of filtration control. The presence of increased calcium levels can be verified from chemical analysis of the filtrate. The combination of high calcium levels and high pH will precipitate most common polymers used in water-based mud. As a result, there will be loss of rheology and filtrate control.

Preventative measures and remedial action can be taken to control the magnesium, and calcium contaminations. Small quantities of magnesium such as those present in seawater can be readily removed with additions of caustic soda.  $Mg(OH)_2$  is precipitated at a pH of approximately 10.5. When large quantities of Mg are encountered (i.e., magnesium shales, evaporites

or brine flows), it is not practical to treat out the contaminant. Large-scale sticky precipitation of  $\text{Mg}(\text{OH})_2$  will adversely affect the rheology. Thus, it increases gel strengths. The large surface area of this precipitate consumes huge quantities of mud chemicals. This is particularly problematic in oil-based mud where surfactants are effectively stripped from the mud and can cause the whole system to “flip”. In these cases, no attempt should be made to adjust the alkalinity until clearing the Mg source. Modern surfactant packages do not generally require a big excess of lime so oil mud performance should not be compromised. A low pH in a water-based mud could promote corrosion of drillpipe. Therefore, we should consider the application of oxygen scavengers and filming amines until the pH can be restored.

Small quantities of calcium (<400 mg/L) are acceptable. In most water-based muds, it is even desirable too. A certain level of calcium acts as a buffer against the presence of undesirable carbonate alkalinity. High concentrations of calcium can, however, have major adverse effects on water-based mud. The major sources of large quantities of calcium are: (i) cement, and (ii) anhydrite.

The chemistry of cement is complex. However, from the mud contamination point of view, it can be lime i.e.,  $\text{Ca}(\text{OH})_2$ . The major contaminant is calcium. However, in some circumstances, the hydroxide ion will compound the problem. At high temperatures (e.g., > 250°F) severely contaminated bentonite-based muds can solidify. When it is planned to drill cement at its initial stage (i.e., particularly when it is not completely hard), some precautions should be taken to minimize the potential effects of the contamination. Some specific treatment can be taken to minimize the effects of calcium which are: (i) if viable, drill out as much cement as possible with seawater before displacing to mud; (ii) minimize caustic soda additions during operations including the mixing of new mud prior to the drilling of cement; (iii) pre-treat with small amounts of  $\text{NaHCO}_3$  which is about 0.25 lb/bbl. If green cement is expected then the amount can be doubled. Avoid over treatment as an excess of bicarbonate in the mud system. It can flocculate mud solids and adversely affects rheology and filtration control; (iv) closely monitor pH and phenolphthalein ( $P_p$ ) while drilling the cement and adjust treatments as required to prevent polymer precipitation (i.e., keep pH below 11.0) and clay flocculation.  $\text{NaHCO}_3$  will reduce calcium and pH; (v) when it is known that large amounts of green or soft cement are to be drilled consideration should be given to converting the mud to a lime system. It is tolerant of cement contamination. Large amounts of a suitable dispersant (e.g., Lignox) must be available to successfully accomplish this conversion. Oil-based and synthetic oil-based muds are largely

unaffected by cement. However, the water fraction of green cement may reduce oil-water ratios. Whenever possible drill out cement with seawater or water-based mud, prior to displacing to oil-based mud.

Anhydrite ( $\text{CaSO}_4$ ) is the anhydrous form of gypsum and is sufficiently soluble to provide calcium ions for clay flocculation. The calcium effects will be as for cement. However, gypsum contamination generally has no direct effect on the pH of the mud. When only small stringers are anticipated, the excess calcium can be treated out with soda ash (i.e.,  $\text{NaHCO}_3$ ). Care should be taken to avoid over treatment, as the adverse effects of carbonate contamination are equally as bad as those of calcium. Small additions of a deflocculant such as Lignosulphonate will smooth out the rheology during treatment. If massive anhydrite is prognosed and a water-based mud is being used, consideration should be given to converting the mud to a gypsum system which is tolerant of calcium contamination. Oil-based muds are unaffected by anhydrite contamination.

**(iii) Carbonates and Bicarbonates:** There are three species of contaminant in the carbonate system: (i) carbonic acid ( $\text{H}_2\text{CO}_3$ ), (ii) bicarbonate ( $\text{HCO}_3^-$ ), (iii) carbonate ( $\text{CO}_3^{2-}$ ). Figure 3.6 shows the equilibrium levels of these species at varying pH levels. There are four common sources of carbonate system contaminants: (i) carbon dioxide from formation gases, e.g., over treatment when removing calcium from the mud (i.e., excess use of soda ash and sodium bicarbonate), (ii) thermal degradation of organic mud products (e.g., FCL, lignite and starch), (iii) contaminated barite (i.e., particularly when drilling HTHP wells with water-based mud), and it is essential that quality assurance/quality control procedures are applied to all batches of barite prior to shipment to such wells, and (iv) contaminated bentonite. The symptoms of carbonate system are characterized by

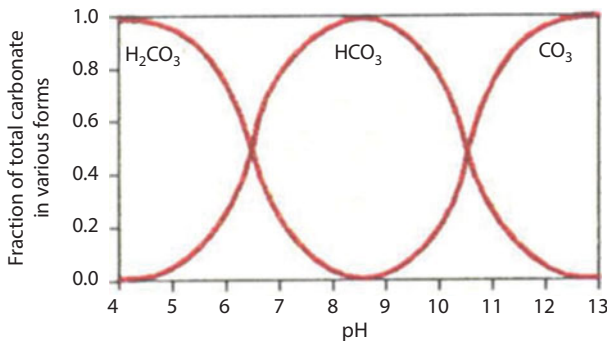

Figure 3.6 Equilibrium levels of carbonates and bicarbonates.



general increases in rheology, particularly yield point and gel strengths, and increases in filtrate. Typically, these effects are worse in high-solids mud, and in high-temperature applications. The symptoms will not respond to chemical deflocculating such as Lignosulphonate treatment.

To eliminate carbonate and bicarbonate contaminant, some preventative measures and remedial action need to be taken. Prior to treating the contaminants, the situation should be assessed with all available data. Over treatment with the calcium ion should be avoided. pH,  $P_f$  and the methyl orange ( $M_f$ ) are determined by pH meter and by titration to determine the presence of carbonate/bicarbonate contamination and the treatment necessary to alleviate the problem. The ratio and relationship between these values will, in theory, allow carbonate species to be determined. The basic treatment for carbonate contamination is to precipitate the carbonate with the calcium ion derived from either lime ( $\text{Ca(OH)}_2$ ) or gypsum ( $\text{CaSO}_4$ ). The addition of calcium will, however, have effect on bicarbonates. These must first be converted to carbonates by adding hydroxyls. Conventionally, this would be achieved either with caustic soda or with lime. Bicarbonate cannot exist in the presence of hydroxyls. Under normal conditions bicarbonates begin to convert to carbonates at a pH above 9.5.

**(iv) Salts Formations and Brine Flows:** By far the most commonly encountered salt in the drilling industry is sodium chloride ( $\text{NaCl}$ ). Potassium chloride ( $\text{KCl}$ ), calcium chloride ( $\text{CaCl}_2$ ) and magnesium chloride ( $\text{MgCl}_2$ ) are, however, sometimes drilled in complex evaporite sequences. The sources of various chlorides are found in seawater, brine flows, salt domes, salt stringers, and massive complex evaporite formations. For water-based mud, the extent of the effects of contamination depends largely upon the mud type and the concentration and type of contaminating salt. Divalent salts (i.e., calcium and magnesium) will have a greater contaminating effect on water-based muds than mono-valent salts (i.e., sodium and potassium). Freshwater bentonite mud or low salinity mud with active drilled solids will be flocculated by high chlorides or by divalent ions in the salt. Viscosity will initially increase however at very high chloride levels may decrease due to collapse of the clay structure. Low solids polymer muds exhibit good resistance to salt contamination.

Oil-based muds are largely unaffected by drilled salts although the water phase of the mud will increase in salinity and may well reach saturation if massive salt is drilled. Large brine flows can adversely affect oil mud. The mud tends to take on a grainy appearance. The rheology tends to increase as oil/water ratio decreases due to the water content of the brine flow. Chloride content can show marked changes depending upon the

salt content of the brine flow. In extreme cases, saturated brine flows can result in recrystallization of the brine phase of the mud. This can result in removal of crystals at the shakers and a corresponding loss of surfactant. If rapid remedial action is not taken (i.e., replacement of surfactants water wetting of solids will occur and phase separation will result). This can be calamitous in terms of borehole stability and well control. Similar problems can occur if the brine flow contains magnesium chloride. This reacts with lime in the mud and the resulting precipitation of  $Mg(OH)_2$  will strip surfactants from the system.

The use of the correct mud weight will minimize brine flows into the system. The adjustment of mud weight must be the initial step in the prevention of further influx. Early detection of a brine flow will minimize the volume and hence the effects of the brine influx.

Chloride levels cannot practically be reduced by chemical precipitation for water-based mud. Dilution with freshwater may reduce chlorides to tolerable levels. However, this is only feasible in low-density mud. The additions of barite required to maintain mud weight in a high-weight mud would be prohibitive in terms of time and cost. When using a bentonite system, prehydration of the clay in drill water prior to addition to the active system will provide some short-term viscosity and filtration control. For longer-term stability, it will be necessary to substitute salt resistant polymers (e.g., PAC, XC and Starch) for the bentonite.

The symptoms detailed above must be addressed as soon as they are recognized. When magnesium salts are present from drilled formation or from brine flows, addition of lime to the mud should be stopped. When a brine flow is encountered, oil-wetting surfactants must be added steadily until any hint of water wetting is removed. There is an API test for water wetting but an experienced mud engineer will be aware of the problem and begin treatment before the test is underway.

### 3.1.6 Formation Damage

Formation damage is an undesirable operational and economic problem that can occur during the various phases of oil and gas recovery. In general, formation damage refers to the impairment of the permeability of petroleum-bearing formations by various adverse processes (Figure 3.7). Formation damage can also be defined as the impairment of the unseen inevitable situation. It causes an unknown reduction in the unquantifiable permeability. Formation damage is defined as the impairment to reservoir (reduced production) caused by wellbore fluids used during drilling/completion and workover operations. It is a zone of reduced permeability

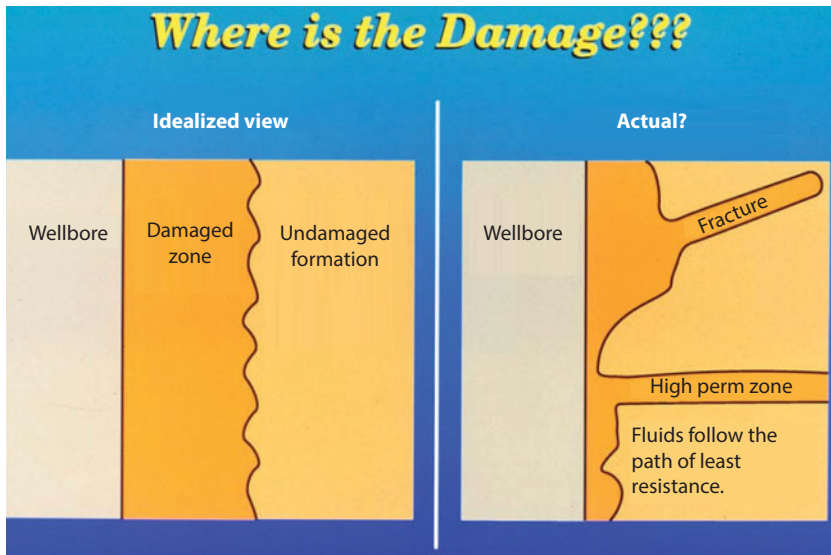

Figure 3.7 Formation damage.

within the vicinity of the wellbore (skin) because of foreign-fluid invasion into the reservoir rock. However, many researchers defined formation damage based on different contexts. According to Amaefule *et al.* (1988), “formation damage is an expensive headache to the oil and gas industry.” Bennion (1999) designated formation damage as, “the impairment of the invisible, by the inevitable and uncontrollable, resulting in an indeterminate reduction of the unquantifiable!” As stated by Porter (1989), “formation damage is not necessarily reversible” and “what gets into porous media does not necessarily come out.” Porter (1989) called this phenomenon “the reverse funnel effect.” Therefore, it is better to avoid formation damage than to try to restore it. Formation damage is an undesirable operational and economic problem that can occur during the various phases of oil and gas recovery from subsurface reservoirs including drilling, completion, stimulation, production, hydraulic fracturing, and workover operations (Civan, 2005). Formation damage indicators are (i) permeability impairment, (ii) skin damage, and (iii) decrease of well performance.

There are many factors which affect the formation damage. These factors are: (i) physico-chemical, (ii) chemical, (iii) biological, (iv) hydrodynamic, (v) thermal interactions of porous formation, particles, and fluids, and (vi) the mechanical deformation of formation under stress and fluid shear. These processes are triggered during the drilling, production,

workover, and hydraulic fracturing operations. As drilling fluid is one of the most important items that significantly influence the formation damage, several factors are considered for minimizing the formation damage while selecting a drilling fluid: (i) fluid compatibility with the producing reservoir, (ii) presence of hydratable or swelling formation clays, (iii) fractured formations, and (iv) the possible reduction of permeability by invasion of nonacid soluble materials into the formation.

The consequences of formation damage are the reduction of the oil and gas productivity of reservoirs and non-economic operation. These are: (i) reduction of reservoir, (ii) productivity, (iii) non-economic operations. Formation damage studies are important for: (i) understanding of these processes via laboratory and field testing, (ii) development of mathematical models via the description of fundamental mechanisms and processes, (iii) optimization for prevention and/or reduction of the damage potential of the reservoir formation, and (iv) development of formation damage control strategies and remediation methods. These tasks can be accomplished by means of a model-assisted data analysis, case studies, and extrapolation and scaling to conditions beyond the limited test conditions. The formulation of the general-purpose formation damage model describes the relevant phenomena on the macroscopic scale; i.e., by representative elementary porous media averaging (Civan, 2002).

Amaefule *et al.* (1988) demonstrated the formation damage mechanisms in four groups: (i) type, morphology, and location of resident minerals; (ii) in-situ and extraneous fluids composition; (iii) in-situ temperature and stress conditions and properties of porous formation; and (iv) well development and reservoir exploitation practices. They also classified the various factors affecting formation damage as: (i) invasion of foreign fluids, such as water and chemicals used for improved recovery, drilling mud invasion, and workover fluids; (ii) invasion of foreign particles and mobilization of indigenous particles, such as sand, mud fines, bacteria, and debris; (iii) operation conditions such as well flow rates and wellbore pressures and temperatures; and (iv) properties of the formation fluids and porous matrix. Figure 3.8 outlines the common formation damage mechanisms based significance. The specific mechanisms are shown in Figure 3.9. They greatly affect the formation damage, which are listed as: (i) clay-particle swelling or dispersion, (ii) wettability reversal, (iii) aqueous-filtrate blockage, (iv) emulsion blockage, (v) asphaltene and sludge deposition, (vi) scale and inorganic precipitation (i.e., mutual precipitation of soluble salts in wellbore-fluid filtrate and formation water), (vii) fines migration, (viii) particulate plugging (i.e., solids), (ix) bacteria, (x) saturation changes, (ix) condensate banking and (x) suspended particles.

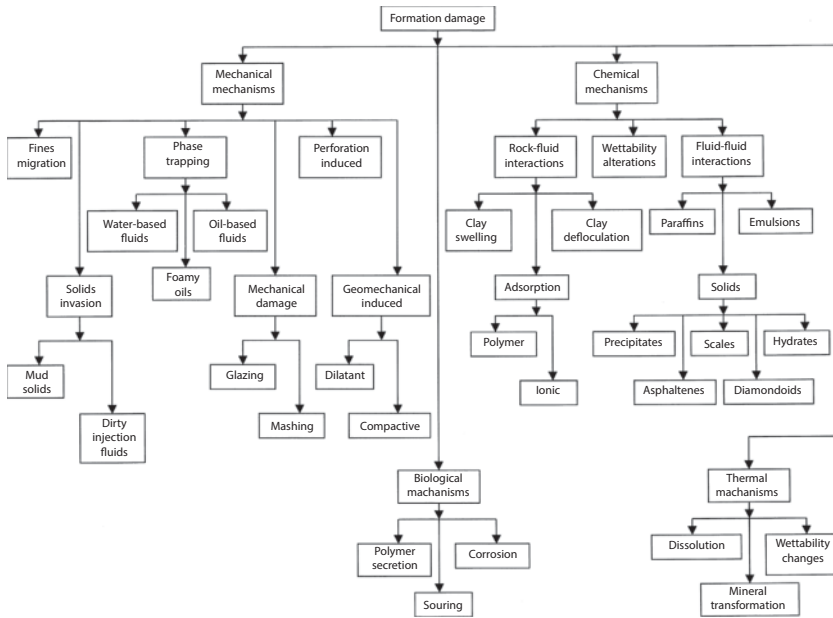

Figure 3.8 Classification and order of the common formation damage mechanisms (modified after Bennion, 1999).

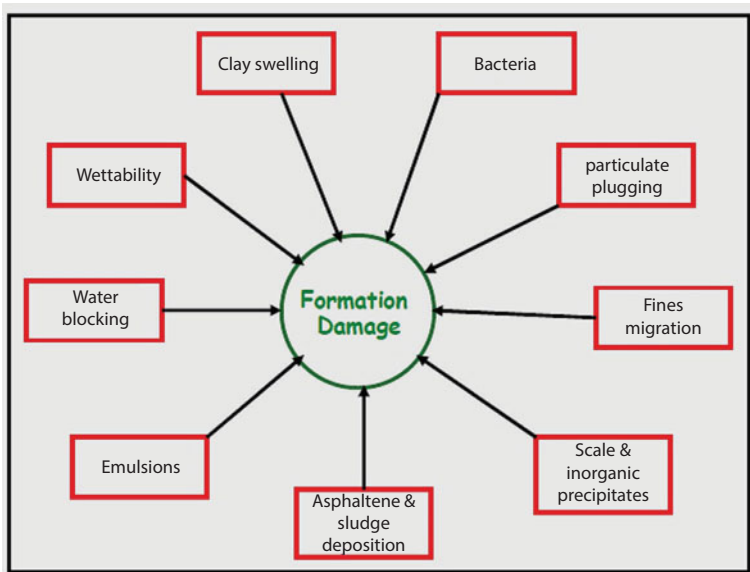
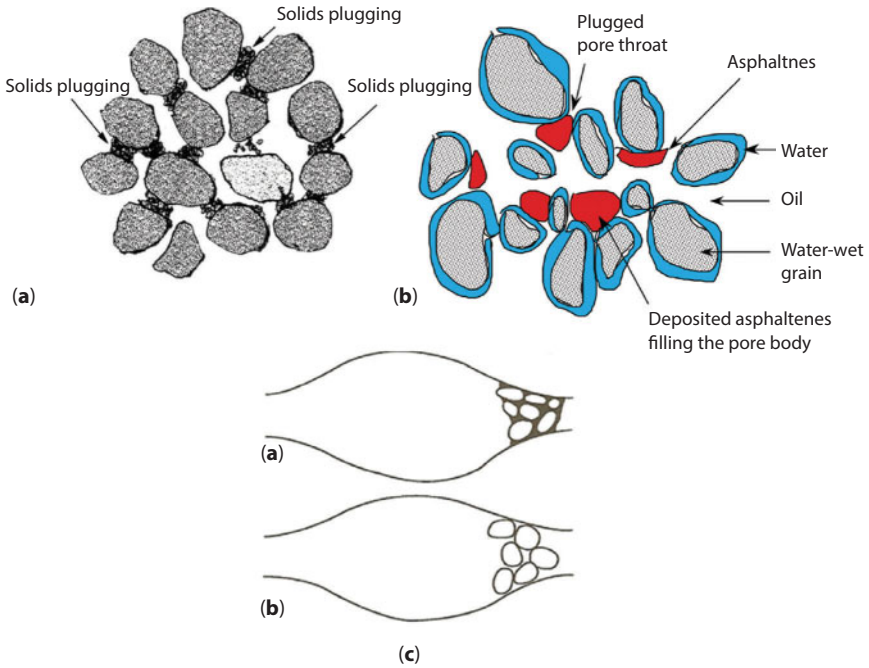

Figure 3.9 Causes of damage.



**Figure 3.10** Formation damage caused by (a) solids plugging, (b) in situ asphaltene deposition, and (c) pore throat plug.

**(i) Solids plugging:** The plugging of the reservoir-rock pore spaces can be caused by the fine solids in the mud filtrate or solids removed by the filtrate within the rock matrix (Figure 3.10). To minimize this form of damage, minimize the amount of fine solids in the mud system and fluid loss.

**(ii) Clay-particle swelling or dispersion:** Clay swelling is defined as “a type of damage in which formation permeability is reduced because of the alteration of clay equilibrium”. Clay swelling occurs when water-base filtrates from drilling, completion, workover or stimulation fluids enter the formation. This is an inherent problem in sandstone that contains water-sensitive clays. Figure 3.11(a–c) shows the formation damage due to adsorption, soil aggregate, and clay swelling. When a fresh-water filtrate invades the reservoir rock, it will cause the clay to swell and thus reduce or totally block the throat areas (Figure 3.11c). Shales also have abundant swelling clays. Swelling does not occur as commonly in producing

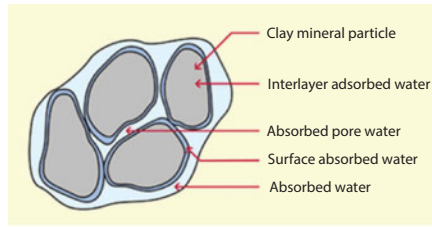

(a)

6.8.0

Water moves through soil with good structure

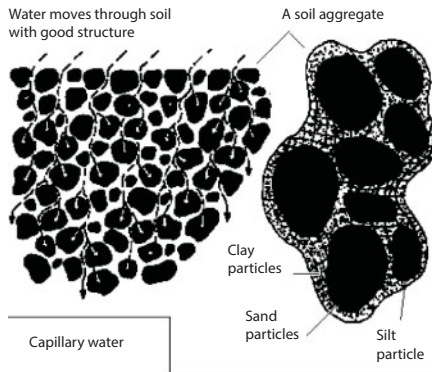

Soil pores between soil particles filled with water



Films of water around soil particles

(b)

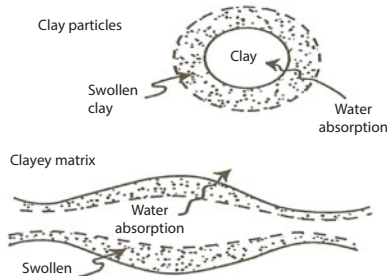

(c)

**Figure 3.11** Formation damage caused by clay particles activities (a) Adsorbed water; (b) Soil pores with water; (c) Clay swelling.

intervals. Thus, formation damage problems with swelling clays are not nearly as common as those associated with fines migration. The most common swelling clays found in reservoir rock are smectites and mixed-layer illites. It was earlier thought that much of the water and rate sensitivity

observed in sandstones was caused by swelling clays. However, it is now well accepted that the water-sensitive and rate-sensitive behavior in sandstones is more commonly the result of fines migration and only rarely of swelling clays.

According to Wikipedia, dispersion is defined as “a system in which particles are dispersed in a continuous phase of a different composition or state”. A dispersion is classified in several different ways including how large the particles are in relation to the particles of the continuous phase, whether or not precipitation occurs, and the presence of Brownian motion. The factors that affect the dispersion and migration of clays are the ways in which they occur in sandstones, particularly their spatial arrangement in relation to the fabric and structural features of the rock (Figure 3.12), their micro-aggregate structure, morphology, surface area, porosity and particle size distribution.

**(iii) Saturation changes:** In general, hydrocarbon production is predicted by employing the amount of saturation within the reservoir rock. When a mud-system filtrate enters the reservoir, it will cause some change in water saturation. Therefore, there is a potential reduction in production.

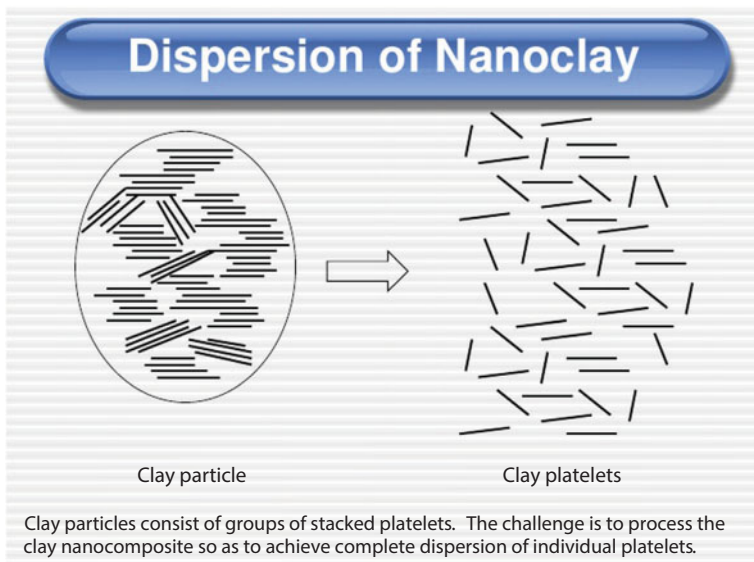

**Figure 3.12** Formation damage caused by dispersion.



Figure 3.13 depicts that high fluid loss causes water saturation to increase. This loss ultimately results in a decrease of rock relative permeability.

**(iv) Wettability reversal:** Reservoir rocks are water-wet in nature. It has been demonstrated that while drilling with oil-based mud systems, excess surfactants in the mud filtrate enter the rock. This invasion can cause wettability reversal. It has been reported from field experience and demonstrated in laboratory tests that as much as 90% in production loss can be caused by this mechanism. Therefore, to protect against this problem, the amount of excess surfactants used in oil-based mud systems should be kept at a minimum level.

**(v) Emulsion blockage:** The presence of emulsions at the surface does not imply the formation of emulsions in the near-wellbore region. Most often, surface emulsions are a result of mixing and shearing that occur in chokes and valves in the flow stream after the fluids have entered the well. It is uncommon to have emulsions and sludges form in the near-wellbore

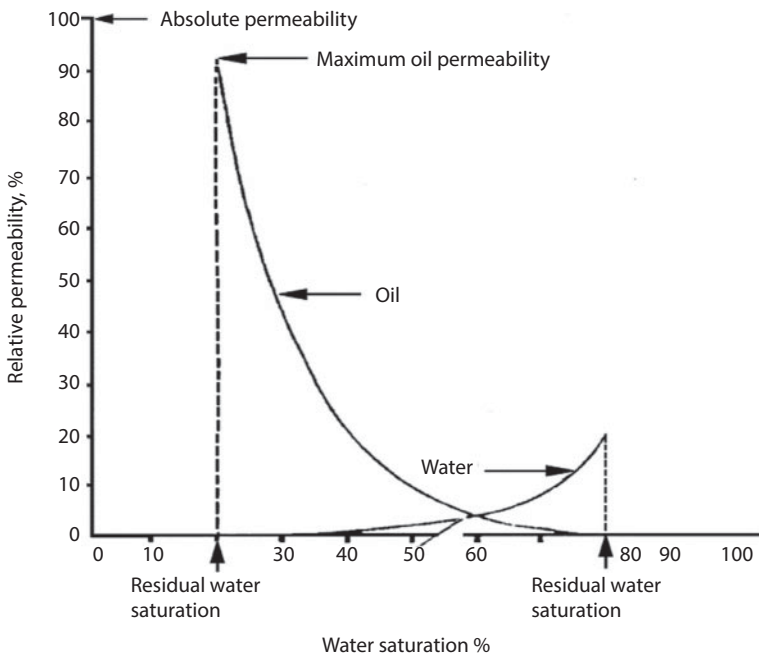

Figure 3.13 Formation damage caused by saturation.

region without the introduction of external chemicals. The mixing of two immiscible fluids at a high shear rate in the formation can sometimes result in the formation of a homogeneous mixture of one phase dispersed into another. Such emulsions usually have a higher viscosity than either of the constituent fluids and can result in significant decreases in the ability of the hydrocarbon phase to flow.

In general, it is difficult to remove emulsions and sludges once they are formed. Thus, it is imperative to prevent the formation of such emulsions. Use of mutual solvents such as alcohols and surfactants are the most common way to remove these deposits from the near-wellbore region. However, because of the unfavorable mobility ratio of the injected fluid, placing the treatment fluids in the plugged zones can be difficult. Again, laboratory tests with the crudes should be conducted to ensure compatibility.

**(vi) Aqueous-filtrate blockage:** If large volumes of water-based drilling or completion fluids are lost to a well, a region of high water saturation around the wellbore forms. In this region, the relative permeability to the hydrocarbon phases is decreased, resulting in a net loss in well productivity. There are three primary methods used to remove water blocks: (i) surging or swabbing the wells to increase the capillary number temporarily, (ii) reducing surface tension through the addition of surfactants or solvents, which also has the net effect of increasing the capillary number by reducing the interfacial tension between the hydrocarbon and water phases so that the water block may be cleaned up during flowback, and (iii) use of solvents or mutual solvents, such as alcohols, to solubilize the water and remove it through a change in phase behavior. These three methods have been successfully applied in the field. The benefit of one method over another depends on the specific conditions of reservoir permeability, temperature, and pressure.

**(vii) Mutual precipitation of soluble salts in wellbore-fluid filtrate and formation water:** Any precipitation of soluble salts, whether from the use of salt mud systems or from formation water or both, can cause solids blockage and hinder production.

**(viii) Fines migration:** Perhaps the most common formation damage problem reported in the mature oil-producing regions of the world is organic deposits forming both in and around the wellbore. These organic deposits fall into two broad categories: (i) paraffins, and (ii) asphaltenes. These deposits can occur in tubing, or in the pores of the reservoir rock. Both effectively choke the flow of hydrocarbons.

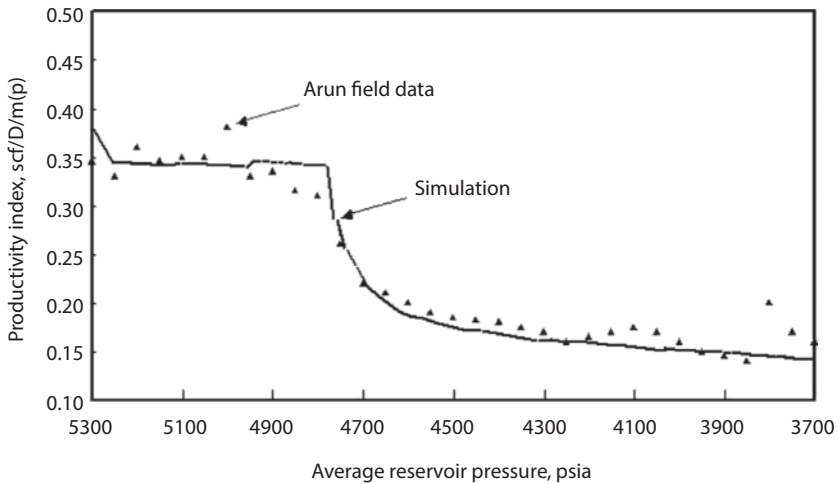

**Figure 3.14** Reduction in well productivity caused by condensate buildup.

**(ix) Condensate banking:** Formation damage in gas/condensate reservoirs can be caused by a buildup of fluids (i.e., condensate) around the wellbore (Figure 3.14). This reduces the relative permeability and therefore gas production. The most direct method of reducing condensate buildup is to reduce the drawdown so that the bottom-hole pressure remains above the dew point. In cases when this is not desirable, the impact of condensate formation can be reduced by increasing the inflow area and achieving linear flow rather than radial flow into the wellbore. This minimizes the impact of the reduced gas permeability in the near-wellbore region. Both benefits can be achieved by hydraulic fracturing.

**(x) Suspended particles:** Formation damage happens during water flooding process when there exist suspended particles in injected water. These particles ultimately lead to a decreased water injectivity rate (i.e., water injection velocity). When water is added into the formation, these particles migrate into the rock (Figure 3.15). If the particles' sizes are greater than pore throats, they clog the wellbore surface and thus forms the external cake. In addition, if the particles' sizes are smaller than pore throats, they enter the formation and thus forms internal filter cake.

### 3.1.6.1 Prevention of Formation Damage

Over the last five decades, a great deal of attention has been paid to formation damage issues for two primary reasons: (i) ability to recover fluids

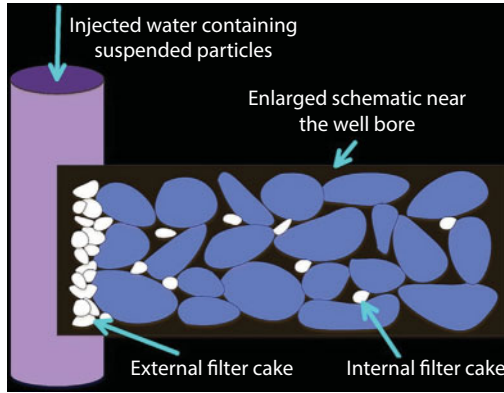

**Figure 3.15** Formation damage caused by suspended particles in injected water (Feng *et al.*, 2016).

from the reservoir is affected very strongly by the hydrocarbon permeability in the near-wellbore region, and (ii) although we do not have the ability to control reservoir rock and fluid properties, we have some degree of control over drilling, completion, and production operations. Thus, prevention of formation damage is very crucial because it (i) can make operational changes, (ii) can minimize the extent of formation damage induced in and around the wellbore, and have a substantial impact on hydrocarbon production, and (iii) can mitigate the awareness of formation damage implications for various drilling, completion, and production operations. As a result, the initiatives can help significantly to reduce formation damage and finally, improve the ability to increase production of hydrocarbon.

There are some techniques which offer the prevention of formation damages. These are: (i) selection of treatment fluids, (ii) clay stabilization, (iii) clay and silt fines, (iv) bacterial damage, (v) well stimulation, (vi) sandstone and carbonate formation acidizing, (vii) lower mud weight, and (viii) water loss control.

**(i) Selection of treatment fluids:** Thomas *et al.* (1998) reported that the type and location of the damage should be determined to select the proper treating fluids. In addition, precautions should be taken to avoid further damage. The formation damage can be from emulsions, wettability changes, a water block, scale, organic deposits (i.e., paraffin and asphaltenes), mix deposits (i.e., a mixture of scale and organic material), silt and clay, and bacterial deposits. In most cases, the type(s) of damage cannot be identified precisely with 100% accuracy. However, the most probable type can be

determined. Therefore, most matrix treatments incorporate treating fluids to remove more than one type of damage.

**(ii) Clay stabilization:** Himes *et al.* (1991) describe the desirable features of effective clay stabilizers, especially for applications in tight formation as follows: (i) the product should have a low, uniform molecular weight to prevent bridging and plugging of pore channels, (ii) the chemical should be non-wetting on sandstone surfaces to reduce water saturation, (iii) it should have a strong affinity for silica (clay) surfaces to compete favorably with the gel polymers for adsorption sites when placed from gelled solutions and to resist wash-off by flowing hydrocarbons and brines, and (iv) the molecule must have a suitable cationic charge to neutralize the surface anionic charges of the clay effectively.

**(iii) Clay and silt fines:** The fluid selection studies conducted by Thomas *et al.* (1998) have indicated that (i) the sandstone formation damage can be treated by fluids that can dissolve the materials causing the damage, and (ii) the carbonate (limestone) formations are very reactive with acid and, therefore, the damage can be alleviated by dissolving or creating wormholes to bypass the damaged zone. If there is a silt or clay damage, hydrochloric acid (HCl) should be used to bypass the damage. The damage by calcium fluoride precipitation cannot be treated by HCl or hydrofluoric acid (HF) treatment. Formation damaged by silt and clay fines introduced by drilling, completion, or production operations require different acid treatment recipes that vary by the formation type, location of damage, and temperature (Thomas *et al.*, 1998).

**(iv) Bacterial damage:** Bacteria growth in injection wells can cause many problems including plugging of the near-wellbore formation. Johnson *et al.* (1999) recommend the use of 10-wt% anthrahydroquinone disodium salt in caustic to control the growth of sulfate-reducing bacteria (SRB) combined with the traditional biocide treatment for control of other types of bacteria. For example, bacteria-induced formation damage in injection wells can be treated using a highly alkaline hypochlorite solution, followed by a HCl overflush for neutralization of the system (Thomas *et al.*, 1998).

**(v) Well stimulation:** Bridges (2000) states that well stimulation is required to remove the damage and to pass the damaged zone. Bridges (2000) classifies the basic stimulation techniques into three groups: (i) mechanical high-pressure hydraulic fracturing, (ii) chemical low-pressure treatment, and (iii) combination of mechanical and chemical approaches.

(vi) **Sandstone and carbonate formation acidizing:** Acidizing is an effective method for removal (by passing) of various types of formation damage and formation stimulation in petroleum reservoirs. It requires properly designed and implemented pre-flush, main-treatment, and after-flush procedures to avoid the formation of precipitates, reaction by-products, and sludge (Tague, 2000a, b, c, d; Martin, 2004). However, under favorable conditions, hydraulic fracturing may be more effective than acidizing for damage removal and formation stimulation (Martin, 2004).

### 3.1.6.2 Quantifying Formation Damage

Formation damage indicators include permeability impairment, skin damage, and decrease of well performance. A commonly used measure of well productivity is the productivity index,  $J$ , in barrels per pounds per square inch, which can be written as:

$$J = \frac{q_0}{\bar{P}_R - P_{wf}} \quad (3.12)$$

The most commonly used measure of formation damage in a well is the skin factor,  $S$ . The skin factor is a dimensionless pressure drop caused by a flow restriction in the near-wellbore region. It is defined as follows (in field units):

$$S = \left( \frac{kh}{141.2q\mu B} \right) \Delta P_{skin} \quad (3.13)$$

Figure 3.16 shows how flow restrictions in the near-wellbore region can increase the pressure gradient, resulting in an additional pressure drop caused by formation damage ( $\Delta P_{skin}$ ).

In 1970, Standing introduced the important concept of well flow efficiency,  $F$ , which he defined as:

$$F = \frac{\bar{P}_R - P_{wf} - \Delta P_{skin}}{\bar{P}_R - P_{wf}} \frac{\text{ideal drawdown}}{\text{actual drawdown}} \quad (3.14)$$

Clearly, a flow efficiency of 1 indicates an undamaged well with  $\Delta P_{skin} = 0$ , a flow efficiency  $> 1$  indicates a stimulated well (perhaps because of a

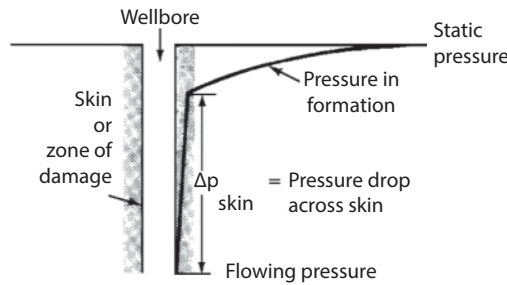

**Figure 3.16** Pressure profile in the near-wellbore region for an ideal well and a well with formation damage (Standing, 1970).

hydraulic fracture), and a flow efficiency  $< 1$  indicates a damaged well. Note that, to determine flow efficiency, we must know the average reservoir pressure,  $\bar{P}_R$ , and skin factor,  $S$ .

The impact of skin on well productivity can be estimated using inflow performance relationships (IPRs) for the well such as those proposed by Vogel, Fetkovich, and Standing. These IPRs can be summarized as follows:

$$\frac{q}{q_{max}} = FY(x + 1 - FYx) \tag{3.15}$$

where

$$Y = 1 - \frac{P_{wf}}{\bar{P}_R} \tag{3.16}$$

when  $x = 0$ , a linear IPR model is recovered; when  $x = 0.8$ , we obtain Vogel's IPR; and when  $x = 1$ , Fetkovich's IPR model is obtained. An example of a plot for the dimensionless hydrocarbon production as a function of the dimensionless bottom-hole pressure (IPR) is shown in Figure 3.17 for different flow efficiencies. It is evident that, as flow efficiency decreases, smaller and smaller hydrocarbon rates are obtained for the same draw-down  $(\bar{P}_R - P_{wf})$ .

The choice of the IPR used depends on the fluid properties and reservoir drive mechanism. Standing's IPR is most appropriate for solution-gas-drive reservoirs, whereas a linear IPR is more appropriate for water drive reservoirs producing at pressures above the bubble point and for hydrocarbons without substantial dissolved gas.

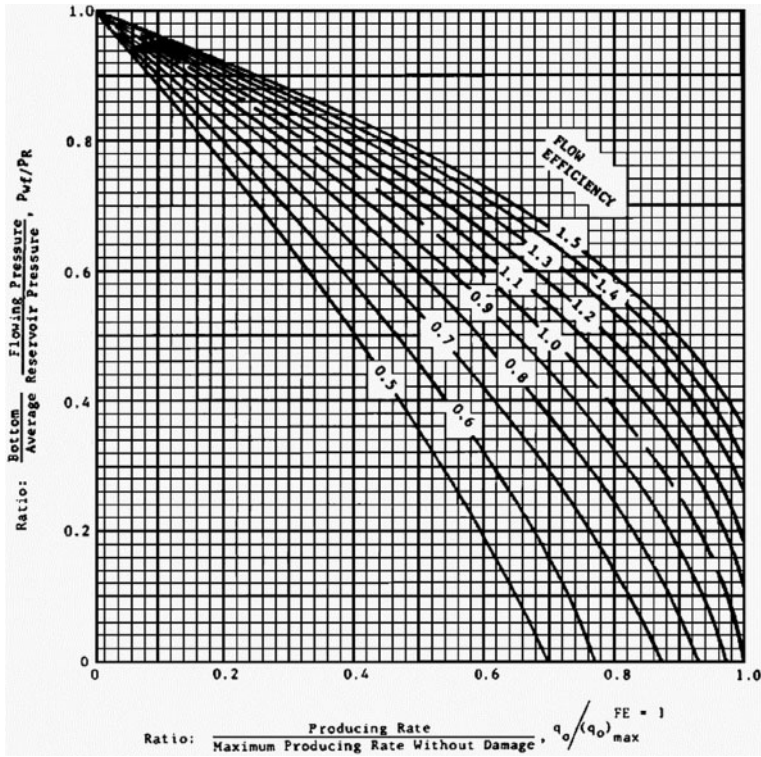

Figure 3.17 Inflow performance relations for different flow efficiencies (F) (Vogel, 1968).

### 3.1.7 Annular Hole Cleaning

Annular hole cleaning is defined as “the ability of a drilling fluid to transport and suspend drilled cuttings”. It is one of the most important mechanisms for cutting transport in rotary drilling. However, proper bottomhole cleaning is very difficult to achieve in practice. The jetting action of the mud crossing through the bit nozzles should provide sufficient velocity and cross flow across the rock face to effectively remove cuttings from around the bit as rock is newly penetrated. This would prevent cuttings from building up around the bit and teeth (i.e., bit balling), prevent excessive grinding of the cuttings and clear them on their way up the annulus, and maximize the drilling efficiency.

There are many factors that affect a part in the efficiency of bottomhole cleaning. These variables include: (i) bit weight, (ii) bit type, (iii) flow rate, (iv) jet velocity, (v) annular fluid velocity, (vi) nozzle size, (vii) location and distance from rock face, (viii) solids volume, (viii) hole inclination angle,



(ix) cutting characteristics, (x) rate of penetration (ROP), (xi) drilling fluid properties, (xii) characteristics of the cuttings, (xiii) drillstring rotational speed, (xiv) differential pressure, and (xv) annulus or pipe eccentricity, etc. Proper bottomhole cleaning will eliminate excessive regrinding of drilled solids, and will result in improved penetration rates. The efficiency of hole cleaning can be achieved through proper selection of bit nozzle sizes. The maximum hydraulic horsepower and the maximum impact force are the two requirements to get the best hydraulic cleaning at the bit. Both these items increase when the circulation rate increases. However, when the circulation rate increases, so does the frictional pressure drop.

Inadequate hole cleaning can lead to costly drilling problems, such as: (i) mechanical pipe sticking, (ii) premature bit wear, (iii) slow drilling, (iv) formation damage (e.g., fracturing), (v) excessive torque and drag on drillstring, (vi) difficulties in logging and cementing, and (vii) difficulties in casings landing. The most prevalent problem is excessive torque and drag, which often leads to the inability of reaching the target in high-angle/extended-reach drilling.

The problem of cuttings transport was studied by many investigators. An extensive literature review is given by Tomren (1979). Recently, increasing attention regarding cuttings transport has been given to directional drilling. According to gravity laws, only the axial component of the slip velocity exists in the case of a vertical annulus:

$$v_s = v_{sa} \tag{3.17}$$

Here

$v_s$  = particle slip velocity, m/s

$v_{sa}$  = axial component of the slip velocity, m/s

This situation changes while the annulus is inclined gradually. The component of the slip velocity appears as:

$$v_{sa} = v_s \cos \theta \tag{3.18}$$

and

$$v_{sr} = v_s \sin \theta \tag{3.19}$$

Here

$v_{sr}$  = radial component of the slip velocity, m/s

$\theta$  = angle of inclination, degree

Obviously, when the angle of inclination is increased, the axial component of the slip velocity decreases, reaching zero value at the horizontal position of the annulus. At the same time, the radial component reaches a maximum in the position mentioned. By taking these conditions into account, one can say that all factors that may lead to improved cuttings transport by a reduction of the particle slip velocity will have a diminishing effect while the angle of inclination is increased. Hole cleaning in directional-well drilling is extensively discussed in the SPE petrowiki website.

The annular mud velocity in vertical drilling should be sufficient to avoid cuttings settling and to transport these cuttings to the surface in reasonable time. As discussed earlier, in the case of an inclined annulus, the axial component of particle slip velocity plays a less important role. One could conclude that to have a satisfactory transport, the annular mud velocity in this case may be lower than in the vertical annulus. However, this would be a misleading conclusion. The increasing radial component of particle slip velocity pushes the particle toward the lower wall of the annulus, and thus causing cuttings (i.e., particle) bed to form. Consequently, the annular mud velocity must be sufficient to avoid (or at least to limit) the bed formation. Studies show that to limit cuttings bed formation, the annular mud velocity in directional drilling should be generally higher than in vertical drilling.

When the cuttings-transport phenomenon is considered, the regime of flowing mud, and vertical slippage should be considered simultaneously. A mud in turbulent flow always induces turbulent regime of particle slippage, independent of the cuttings shape and dimensions. Therefore, in this case, the only factor that determines the particle slip velocity is the momentum forces of the mud. There is no influence of mud viscosity. Turbulent or laminar regime of slippage may be expected if the mud flows in the laminar regime which depends on the cuttings shape, and dimensions. The laminar regime of slippage will always provide a lower value of particle slip velocity. One should conclude that laminar flow usually will provide a better transport than turbulent flow. However, in the case of an inclined annulus, the significance of the axial component of particle slip velocity decreases, and one may expect that an advantage of laminar flow will be nullified while the angle of inclination is increased.

### 3.1.7.1 *New Hole Cleaning Devices*

Hole cleaning is generally considered to be well understood when drilling deviated and horizontal holes. Less than optimal hole cleaning can lead to: (i) non-productive time, (ii) poor bore-hole quality, and (iii) loss of drillstring or even the well. Therefore, hole cleaning was given proper

attention because it affects many drilling parameter and leads at the end to high equivalent circulating density (ECD). As a result, it is very important to find a way to improve cutting removal and prevent cuttings from settling in the low side of the deviated hole sections. The right approach is to plan and address hole cleaning. One of these approaches is the use of Mechanical Hole Cleaning Devices (MHCD) which are good in drilling highly deviated sections with large hole sizes. These tools gradually reduce cutting bed height by mechanical erosion of cutting beds buildup where they cannot be avoided under normal drilling conditions. These tools use the hydrodynamic and hydro-mechanical effect.

One type of these tools is Hydroclean™ drillpipes (Figure 3.18). This tool is developed by the VAM drilling company. It consists of two sections: (i) the hydrocleaning zone which provides optimum scooping effect while the variable helix angle accelerates the cuttings and recirculates them on the high side of the hole, and (ii) the hydro-bearing zone which protects the wellbore from the blades and provides less frictional load and better sliding properties. The optimum string design is to use Hydroclean™ drillpipes in deviated hole more than 40° angles, and one Hydroclean™ drillpipe every three stands of drillpipes.

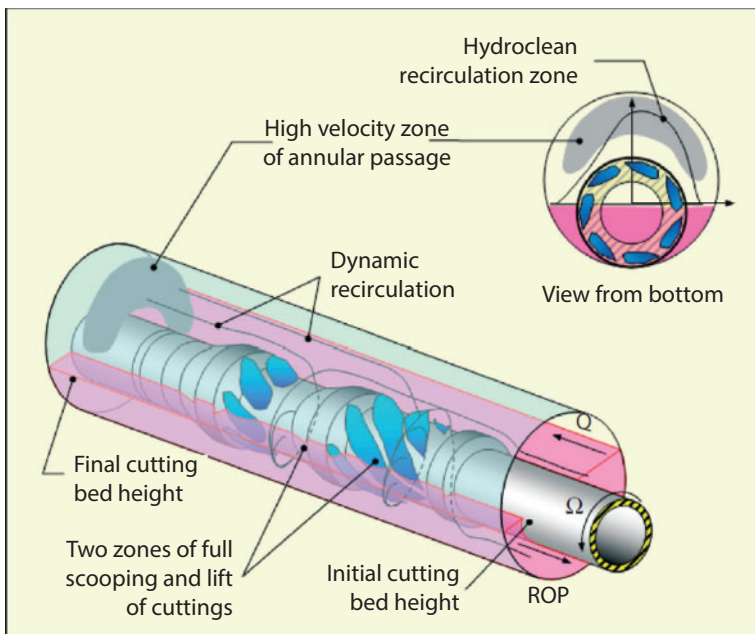
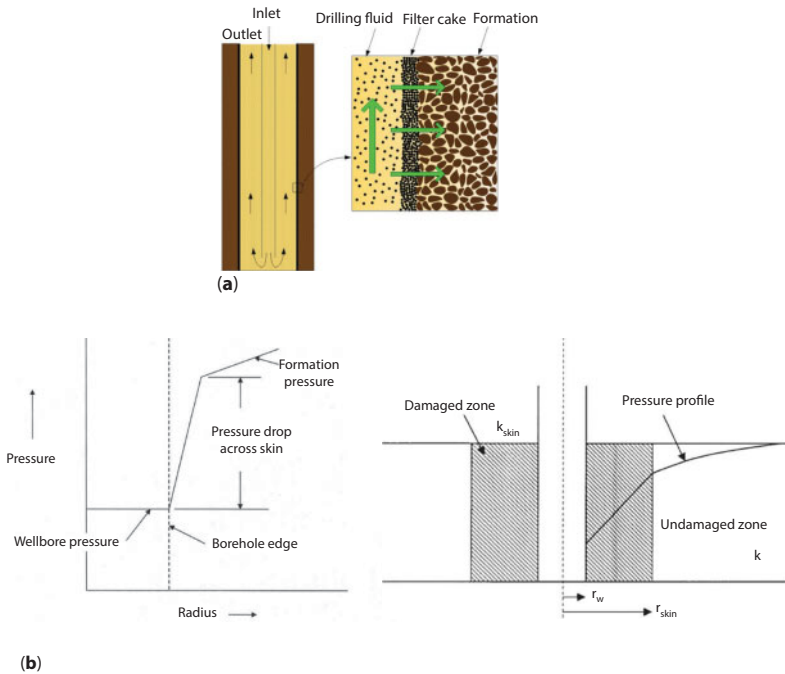

Figure 3.18 Features of Hydroclean™ drillpipe (Hossain and Al-Majed, 2015).

### 3.1.8 Mud Cake Formation

Mud Cake is a layer formed by solid particles in drilling mud against porous zones due to differential pressure between hydrostatic pressure and formation pressure and it always occurs while drilling the wells. It is defined as the solid clay deposit formed in a borehole on a permeable layer when the liquid mud filtrate (i.e., filtrate is the liquid that passes through the medium, leaving the cake on the medium) permeates into the surrounding rocks (Figure 3.19). It is also named as filter cake, mudcake, and wall cake. It is a cover of mud solids that forms on the wall of the borehole when liquid from mud filters into the formation. Mud cake provides a physical barrier to prevent further penetration and loss of drilling fluid, soon after drilling a loss of produced fluids into a permeable formation. If the mud cake thickness increases, the flow resistance of the filter cake increases. After a certain time of usage, the filter cake should be removed from the filter (e.g., by backflushing). If this is not accomplished, the filtration is disrupted because the viscosity of the filter cake gets too high. Thus, it is important to flush the filter cake for avoiding the filter plugs.



**Figure 3.19** An overview of the drilling process and formation of the filter cake (redrawn from Hashemzadeh and Hajidavalloo, 2016) (a) an overview of formation damage; (b) details showing positive and negative skin effect with pressure profil.

Mud tests are conducted to determine filtration rate, and mud cake properties. Cake properties such as cake thickness, toughness, slickness, and permeability are important. For drilling operation, the filter cake is desirable because it is impermeable and thin. In general, the filter cake should be less than or equal to 1/16 inch. Excessive filtration and thick filter cake development in the wellbore can cause serious drilling problems such as: (i) tight hole causing excessive drag, (ii) increased pressure surges due to reduced hole diameter, (iii) differential sticking due to an increased pipe contact in filter cake, and (iv) excessive formation damage and evaluation problems with wireline logs.

Reduced oil and gas production can result from reservoir damage when a poor filter cake allows deep filtrate invasion. However, mud cake formation on the wall of a wellbore is important from the point of view of fluid loss and formation damage control. A certain degree of cake buildup is desirable to isolate formations from drilling fluids. The low permeability mud cake significantly reduces the invasion of the mud solids and the mud filtrate. It has been generally accepted that if an effective mud cake is formed, the mud filtration rate is independent of the overbalance drilling pressure. This occurs because the mud cake permeability decreases with increasing overbalance pressure. However, for low permeability formations, a mud cake may not be formed at all when small overbalance drilling pressures are used. In this case, low overbalance drilling pressures may result in an increase in the fluid loss rate and more damage due to mud solids invasion.

### 3.1.8.1 *Filtration Tests*

The filtration properties of a fluid determine its ability to form a controlled filter cake in the formation. In a mud system, the filtration properties affect borehole stability, smooth movement of the drillstring, formation damage, and development time. The filter cake should not exceed a 16th of an inch in thickness and should be easily removable with the back flow. The filter cake controls the loss of liquid from a mud due to filtration. The test in the laboratory consists of measuring the volume of liquid forced through the mud cake into the formation in a 30-minute period under given pressure and temperature conditions using a standard size cell. There are two commonly filtration rates used: (i) low-pressure low-temperature, and (ii) the high-pressure high-temperature. Controlled high filtrate will minimize chip hold down and provide for faster drilling. Low filtrate may be desirable to combat a tight hole caused by thick filter cake, differential pressure sticking, and the formation of productivity damage. In terms of rheology, high viscosity and gel strength may be preferred to combat high

torque bridging, drag, and fill caused by borehole cleaning, and to provide good suspension of weight material. Low viscosity and gel strength result in faster drilling and the more efficient separation of drilled solids.

### 3.1.8.2 *Mud Cake Removal Using Ultrasonic Wave Radiation*

The drilling fluid consists of combination liquids, solids, and chemicals. The additives of the mud are used to seal the borehole by the solid and polymer bridging on the formation face for stabilizing the wellbore. Since the solids do not freely enter the formation pore spaces, a layer of high-density cake deposits on the borehole wall. The thickness of the cake increases until the cake's permeability approaches zero. This can occur under dynamic or static fluid conditions. Interactions of reservoir with drilling and completion fluids, mud cake and mud filtration lead to near wellbore damages due to plugging the pores with solid particles. This results in reduction of production rate. It is not always possible to prevent formation damage completely. To remove or mitigate the impact of formation damage, well stimulation techniques have been used in the industry for more than half a century.

Applications of ultrasonic waves have been widely developed in petroleum processes due to their significant positive effects. Beresnev and Johnson (1994) provided a comprehensive review of methods using elastic wave stimulation of oil production, including both ultrasonic and seismic methods. They mentioned that the elastic wave and seismic excitations to porous media affect permeability and production rate in most cases. Vakilinia *et al.* (2011) studied the effect of ultrasound on the cracking process of heavy crude oil. Neretin and Yudin (1981) observed an increase in rate of oil displacement by water through loose sand under ultrasound. Vibration causes fluctuations in capillary pressure and expansion of surface films and would result in peristaltic transport of fluid in porous media. This can be a possible explanation for permeability changes. Hamida and Babadagli (2005) observed that ultrasonic waves may enhance capillary imbibition oil recovery depending on the fluid and matrix fracture interaction type. They showed the effect of ultrasonic wave on permeability enhancement of a porous media damaged by mud filtration through six experiments. They concluded that (i) the study illustrates the successful application of ultrasonic waves radiation for near wellbore damage reduction resulted by mud cake removal and mud filtration treatment, and (ii) it has been found that the average optimum time of ultrasonic wave radiation for mud cake removal was 10 sec and for mud filtration treatment was 300 sec, permeability of damaged zone in all experiments tends to the maximum amount that can be reached.

3.1.8.3 Wellbore Filter Cake Formation Model

Despite many experimental studies of the invasion of mud filtrates in laboratory cores, there have been only a few reported attempts to mathematically model the problem. Clark *et al.* (1990) have developed a three-parameter empirical model for accurate correlation of dynamic fluid loss data. Jiao and Sharma (1992) proposed a simple model based on a power law relationship between the filtration rate and the shear stress at the cake surface. The mass balance equations for the filter cake can be written by Eqs. 3.20–3.22. The equations represent the flowing phase containing particles, and the fine particles in the flowing phase. It was assumed that the diffusive transport is neglected.

$$\frac{\partial}{\partial t}(\varepsilon_s \rho_s) + \nabla \cdot (\rho_s \bar{u}_s) = \varepsilon_s \dot{m}_s \equiv R_A \tag{3.20}$$

$$\frac{\partial}{\partial t}(\varepsilon_l \rho_l) + \nabla \cdot (\rho_l \bar{u}_l) = \varepsilon_l \dot{m}_l \equiv -R_A \tag{3.21}$$

$$\frac{\partial}{\partial t}(\varepsilon_l \rho_{Al}) + \nabla \cdot (\rho_{Al} \bar{u}_l) = \varepsilon_l \dot{m}_{Al} \equiv -R_A \tag{3.22}$$

Here

- $t$  = time
- $\nabla$  = divergence operator
- $\rho$  = phase density
- $\dot{m}$  = net rate of the mass
- $\varepsilon$  = fractional volume
- $R_A$  = mass rate of smaller particles

The overall mass balance of particles for the filter cake is given by the following generalized equation given as:

$$\int_0^t (\rho_{Al} q_l)_{mud} = \int_0^t (\rho_{Al} q_l)_{filtercake} + \int_{V_c} \varepsilon_l \rho_{Al} dV + \int_{V_c} \varepsilon_f \rho_f dV \tag{3.23}$$

Here  $V_c$  is the filter cake volume. The equation of motion given by Chase and Willis for deforming filter cake matrix can be written as following:

$$\varepsilon_s \nabla \rho_s - \varepsilon_l \nabla \rho_l + \nabla \cdot \tau_s + \varepsilon_s (\rho_s - \rho_l) = 0 \tag{3.24}$$

The volume flux of the flowing phase relative to the solid matrix is given by Smiles and Kirby as:

$$\vec{u}_r = \varepsilon_l(\vec{v}_l - \vec{v}_s) = \vec{u}_l - \varepsilon_l \vec{v}_s = -k(\varepsilon_l) v_l^{-1} \nabla \rho_l \quad (3.25)$$

### 3.1.9 Excessive Fluid Loss

Fluid loss can be defined as a loss of liquid phase of drilling fluid, slurry or treatment fluid containing solid particles into the formation matrix. Anytime there is a fluid loss, it has the risk of introducing imbalance in the continuous phase. For instance, whenever liquid phase of the drilling fluid seeps out of the drilling mud, the mud consistency will suffer. In addition, any buildup of solid at the surface of the matrix will create a problem due to very low permeability that ensues such filtration. If this matrix is the producing zone, then some treatment, such as Tip screen out (TSO) that creates mini fractures to restore permeability of the damaged interface may be necessary. For the fluid part, addition of more liquid in the short term and fluid-loss additives in the long run may be necessary. If such zones of high permeability that is amenable to fluid loss, mud constitution should be adjusted with fluid-loss additives. It is typically recognized that fluid loss is triggered by one or more of the following factors: (i) excessive mud pressure that creates high pressure drop at the “face” of the formation matrix; (ii) the formation particles are bigger than three times the size of the largest particle present in the mud in substantial quantities (this is due to bridging that leads to filtration); (iii) the formation has abundance of fractures or fissures; (iv) the mud is not stable under prevailing conditions of the formation.

Fluid loss at some level is inherent to any mud, both water-based and oil-based, albeit at much smaller rate for oil-based muds. A continuous liquid phase is necessary for the important functions of a drilling project. Whenever the mud encounters high permeability or more accurately high effective permeability of the continuous phase of the mud, excessive fluid loss may occur. While it is customary to introduce large amounts of water in order to compensate for fluid loss in permeable formations, sudden changes in rock permeabilities cannot always be predicted and can pose a problem during the drilling process. The immediate outcome of excessive fluid loss is the loss of circulation. With proper geological analysis, an on-site geologist can shed light on the level of fluid loss in the formation.

As soon as the excessive fluid loss is observed, as noted by the loss of return circulation, the three-way valve should be switched off in order to direct the drilling fluid back to the pit through the by-pass hose (this



minimizes the loss of valuable water). Following this operation, the drillpipe should be pulled up promptly 1–2 meters from the bottom of the borehole. This would trigger jamming of the open hole leading to possible collapse, thus sealing the permeable zone until future action.

The follow-up response to excessive depends on the type of mud. If the mud already contains bentonite clay (sodium montmorillonite) for a high viscosity mud quality, one must make sure that sufficient time has elapsed to insure complete hydration of the clay prior to it being circulated into the hole (Driscoll, 1986). This also dictates that a waiting period for allowing the mud to gel properly can be adequate at times. At lower velocities, the viscosity is higher because electric charge on the clay particles will hold in a tighter bond. After a certain period, the clay in the drilling fluid will gel. After the waiting period, once the recirculation is commenced, it may be necessary to jar the drillpipe in order to free the mud in the drillpipe.

In case excessive fluid loss has not subsided, geological data should be consulted and cuttings analyzed. It is possible that a high permeability zone within the oil/gas-bearing formation has been struck. Upon consultation with well-site geologist, well testing may be recommended. In case the depth of penetration is not sufficient and further drilling is required, thickening of the mud must be performed prior to restarting the drilling operation.

In case the fluid loss is very high, indicating fractures, vugs, or other form of a sink in the formation, additional blocking agents, such as flaky or fibrous materials, such as bran, husks, chaff, straw, bark, wood chips, cotton, feathers, or any other material that is readily available locally should be added to the mud. A plug containing these materials should be pumped through the drillpipe in order to block access to the fractures.

As an extreme measure, the so-called 'gunk squeeze' can be used. It involves squeezing a gunk plug, containing a large volume of clay or even cement, into a zone of lost circulation. During this operation, annular blowout preventers are closed and pressure is applied by further pumping to force the gunk into the loss zone. Typically, a slurry that consists of bentonite, cement or polymers mixed into an oil (bentonite in diesel oil is commonly used) is used as a gunk plug. Alternatively, the bentonite mix can be lowered into the hole inside a bag that can be ruptured after the plug reaches the desired depth in the face of the high-permeability zone. Water downhole interacts with the bentonite, cement or polymers to make a sticky gunk that can effectively seal the formation that caused excessive fluid loss.

If the gunk squeeze fails to stop the fluid loss, it is possible to carry on the drilling, even without return circulation. Naturally, the cuttings will

drop off in the formation, creating natural plugging. However, if the mud loss is tremendous, it is recommended that high-viscosity mud plugs be injected intermittently as the mud injection continues. If there is no risk of blow out, meaning the drilled formation is not a productive zone, this drilling process can be effective. If deemed necessary, a casing operation can be put in place. Often, placing a casing can remedy the situation and follow up drilling can take place shortly after placement of the casing, albeit with a smaller diameter. It is only in extreme cases that the hole should be abandoned or another drilling entry sought.

### 3.1.10 Drilling Fluid Backflow

Any back flow relates to pressure differences between the zones. Any time the pressure at a higher depth rises above the average pressure prevailing above in the drillpipe, backflow occurs. During a drilling operation, backflow is manifested through mud flow once the swivel is disconnected. It is caused by the pressurization caused by falling formation particles that end up pushing the drilling fluid up toward the Derrick. The backflow is an indication that the wellbore has not been cleaned and the cuttings not been removed adequately. During such backflow, the drillpipe should be reconnected immediately and mud should be circulated to clean up the wellbore. In case caving of the wellbore is suspected, the mud viscosity should be raised in order to restore the stability of the wellbore.

## 3.2 General Case Studies on Lost Circulation

Lost circulation has a big economic impact on the drilling industry annually, as it affects the oil companies indirectly by causing an additional cost of hundreds of millions US dollars to the planned operations (Stangeland, 2015). In the time period 1990–1993, six wells in the North Sea were evaluated for a cost analysis, in order to look for improvements during the operations (Aadnøy, 2010). The borehole stability problems encountered during the pre-drilling of the wells are shown in Table 3.3. It is seen that out of the total NPT, lost circulation is one of the greatest challenges.

Wærnes (2013) presented a case study involving a well drilled in Tanzania. This well experienced some major losses at two very different locations in the well, marked with bold circles in Figure 3.20. At around 4,000 meters the losses became such a big problem that a contingency liner had to be run to prevent further losses. To facilitate cementing of the liner, a low weight base fluid was pumped into the annulus that would sufficiently

**Table 3.3** Time lost during various operations in North Sea (from Stangland, 2015).

Event	Time used (days)
Circulation losses	15
Tight hole	2
Squeeze cementing	15
Stuck casings	20
Fishing	2
Total	52 days
Per well	8.7 days

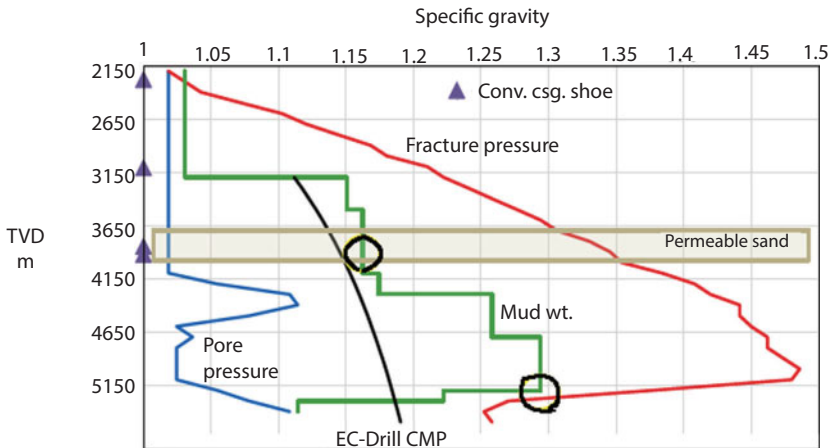

**Figure 3.20** Pore pressure/Fracture pressure curve (Case Study of Tanzania).

lower the hydrostatic pressure, enabling the correct cementing parameters to be maintained, maintaining static and dynamic losses to a minimum.

Starting at around 5000 mTVD, an unanticipated abrupt decrease in fracture pressure resulted in using a mud weight that was close to the formation fracture pressure. This resulted in excessive static and dynamic losses. As a remedy to these losses, a large number of lost circulation pills were pumped, but without success. The next decision was to reduce the mud weight. To further eliminate the losses, the mud weight had to be decreased. The partial EC-Drill line in Figure 3.20 is generated using a mud specific gravity of 1.3 and a mud level at 100 meters above seabed. Note that losses are not only experienced in parts with close proximity to

the fracture pressure gradient as one normally would expect, the uppermost circle is more or less centralized in the operational window, with sufficient margin to both the pore and fracture pressure. Upon inspection of lithological data, it was discovered that the zone was a highly permeable sand formation, which led to the losses experienced during circulating. Due to an anticipated pore pressure ramp up, the previous casing had to be set in a permeable sand formation, resulting in continued losses as the last part of the sand was drilled. On completion of that section, to further limit losses, a contingency liner had to be run.

Introducing the EC-Drill or CMP system to this well, with its quick loss detection capabilities, may have resulted in the overall losses being kept to a minimum, or subsequently removing them altogether. Additionally, there would be a high probability of saving a liner or casing string. Drilling through the permeable sand zone with the EC-Drill may have reduced the losses to a level deemed acceptable, effectively saving to run and cement the contingency liner.

### **3.2.1 Lessons Learned**

If the pore pressure ramp up and decreasing fracture pressure had been correctly anticipated, the mud program might have been slightly different than what was actually chosen. Readily, using the EC-Drill to generate similar curves described in Figure 3.20 would have reduced the overall drilling time, through increased ROP made possible by reducing the wellbore pressure compared to what was achieved by conventional means. Additionally, by reducing the wellbore pressure, and subsequently the differential pressure between the well and the formation, the risk of differentially sticking the pipe is also reduced. And perhaps more importantly the major losses experienced in the lower section may have been avoided all together.

## **3.3 Summary**

This chapter attempts to include all drilling problems and their solutions related to drilling mud and its system only. The different problems while drilling are explained in addition to their possible solutions, preventions, along with case studies. The chapter covers the industry and laboratory practices related to drilling problems and their solutions due to drilling mud system. The mud system is not covered extensively in the chapter because it is available in any drilling fluid manual and as such outside of the scope of this book. A state-of-the-art literature on the drilling fluid has

been completed to address some of the problems encountered that involve mud engineering. The chapter presents the current practices of the technology and identifies where the R&D personnel need to focus their attention in terms of problems and solutions related to drilling mud. In addition, future research guidelines are presented focusing on the development of environmentally friendly drilling fluids with zero/negligible impact on the environment. Efforts should be intensified towards developing alternatives that will transform the mud technology to a sustainable one.

## References

- Abrams, A. and Vinegar, H.J. (1985). Impairment Mechanisms in Vicksburg Tight Gas Sands. Presented at the SPE/DOE Low Permeability Gas Reservoirs Symposium, Denver, Colorado, 19–22 March. SPE-13883-MS.
- Afidick, D., Kaczorowski, N.J., and Bette, S. (1994). Production Performance of a Retrograde Gas Reservoir: A Case Study of the Arun Field. Presented at the SPE Asia Pacific Oil and Gas Conference, Melbourne, Australia, 7–10 November 1994. SPE-28749-MS.
- Alfsen, T.E. *et al.* “Pushing the Limits for Extended Reach Drilling: New World Record from Platform Statfjord C. Well C2,” SPEDC ~June 1995, 71; Trans., AIME, 299
- Alsaba, M., Al Dushaishib, M.F. *et al.*, 2017, Updated criterion to select particle size distribution of lost circulation materials for an effective fracture sealing, *J. Pet. Sci. Eng.*, 149, 641–648.
- Amaefule, J.O., Ajufo, A., Peterson, E., and Durst, K. (1987). Understanding Formation Damage Processes,” SPE 16232 paper, Proceedings of the SPE Production Operations Symposium, Oklahoma City, Oklahoma, 1987.
- Azouz, I., Shirazi, S.A., Pilehvari, A. *et al.* (1993). Numerical Simulation of Laminar Flow of Yield-Power-Law Fluids in Conduits of Arbitrary Cross-Section. *Trans. of ASME* 115(4): 710–716.
- Barnum, R.S., Brinkman, F.P., Richardson, T.W. *et al.* (1995). Gas Condensate Reservoir Behaviour: Productivity and Recovery Reduction Due to Condensation. Presented at the SPE Annual Technical Conference and Exhibition, Dallas, Texas, 22–25 October 1995. SPE-30767-MS.
- Becker, T.E. (1982). The Effect of Mud Weight and Hole Geometry Variations on Cuttings Transport in Directional Drilling. MS thesis, U. of Tulsa, Tulsa, USA.
- Becker, T.E., Azar, J.J., and Okrajni, S.S. (1991). Correlations of Mud Rheological Properties Wit Cuttings-Transport Performance in Directional Drilling. *SPE Drilling Engineering*, March 1991, 16; Trans., AIME, 291.
- Beirute, R.M., Sabins, F.L. and Ravi, K.M. (1991). Large Scale Experiments Show Proper Hole Conditioning: A Critical Requirement for Successful Cementing Operations. SPE 22774, 66th Annual Technical Conference and Exhibition of the Society of Petroleum Engineers, Dallas, 1991.

- Bennion, B. (1994). Experts Share Views on Formation Damage Solutions. *Journal of Petroleum Technology*, November 1994, 936–940.
- Borchardt John, K. 1989. Cationic Organic Polymer Formation Damage Control Chemicals. In *Oil-Field Chemistry*, 396, 396, 10, 204–221. ACS Symposium Series, American Chemical Society.
- Borchardt, J.K., Roll, D.L., and Rayne, L.M. 1984. Use of a Mineral Fines Stabilizer in Well Completions. Presented at the SPE California Regional Meeting, Long Beach, California, 11–13 April 1984. SPE-12757-MS.
- Brown, N.P. and Bern, P.A. “Cleaning Deviated Holes: New Experimental and Theoretical Studies,” paper SPE/IADC 18636 presented at the 1989 SPE/IADC Drilling Conference, New Orleans, 28 February–3 March.
- Browne, S.V., Ryan, D.F., Chambers, B.D. *et al.* 1995. Simple Approach to the Cleanup of Horizontal Wells with Prepacked Screen Completions. *J. Pet Technol.* 47 (9): 794–800. SPE-30116-PA.
- Cameron, C. 2001. Drilling Fluids Design and Management for Extended Reach Drilling. Presented at the SPE/IADC Middle East Drilling Technology Conference, Bahrain, 22–24 October. SPE-72290-MS.
- Carlson, V., Bennett, E.O., and Jr., J.A.R. 1961. Microbial Flora in a Number of Oilfield Water-Injection Systems. *SPE J.* 1 (2): 71–80. SPE-1553-G.
- Chinwuba, Igwilu Kevin. *Fundamentals of Drilling Fluids Technology*. 2000. 88p.
- Cimolai, M.P., Gies, R.M., Bennion, D.B. *et al.* 1993. Mitigating Horizontal Well Formation Damage in a Low-Permeability Conglomerate Gas Reservoir. Presented at the SPE Gas Technology Symposium, Calgary, Alberta, Canada, 28–30 June. SPE-26166-MS.
- Civan, F., “Applicability of the Vogel–Tammann–Fulcher Type Asymptotic Exponential Functions for Ice, Hydrates, and Polystyrene Latex,” *Journal of Colloid and Interface Science*, 285, 2005a, 429–432.
- Clark, Peter E., and Barkat, Omar, Analysis of Fluid-Loss Data, *SPE Production Engineering*, pp. 306–310, 1990.
- Combs, G.D and Whitemire, L.D. Capillary Viscometer Simulates Bottom-Hole Conditions, *Oil and Gas Journal* p. 108–113, 1968.
- Coppel, C.P., Jennings Jr., H.Y., and Reed, M.G. 1973. Field Results from Wells Treated with Hydroxy-Aluminum. *J Pet Technol* 25 (9): 1108–1112. SPE-3998-PA.
- De Wolf, R.C. *et al.* Effects of Temperature and Pressure on Rheology of Less Toxic Oil Muds, Paper SPE11892, 1983.
- Dingsøyr, Eldar *et al.* Oil Based Drilling Fluids with Tailor-Made Rheological Properties: Results from a Multivariate Analysis, Annual Transactions of the Nordic Rheology Society Vol 12, 2004.
- Driscoll, F. (1986) *Groundwater and Wells*, St. Paul: Johnson Division.
- Feng, Q. Chen, H., Wang, X., Wang, S., Wang, Z., Yang, Y., and Bing, S. (2016). Well control optimization considering formation damage caused by suspended particles in injected water. *Journal of Natural Gas Science and Engineering* 35 (2016), pp. 21 – 32.

- Ford, J.T. *et al.* "Experimental Investigation of Drilled Cuttings Transport in Inclined Boreholes," paper SPE 20421 presented at the 1990 SPE Annual Technical Conference and Exhibition, New Orleans, 23–26 September.
- Fordham, E. J. and Ladva, H. K. J. "Crossflow Filtration of Bentonite Suspensions," *J. of Colloid and Inter. Sci.* (Jan. 1992), Vol. 48. No.1, 29–34.
- Ghalambor, A., Salehi, S., Shahri, M.P., Karimi, M. 2014. Integrated workflow for lost circulation prediction. Presented at the SPE International Symposium and Exhibition on Formation Damage Control, Lafayette, Louisiana, 26–28 February. SPE-168123-MS. <http://dx.doi.org/10.2118/168123-MS>.
- Guild, G.J., T.H. Hill Assocs.; Wallace, I.M., Phillips Petroleum Co. U.K.; Wassenborg, M.J., Amoco U.K.: Hole Cleaning Program for Extended Reach Wells, 29381-MS.
- Hashemzadeh, S.M., and Hajidavalloo, E. (2016). Numerical investigation of filter cake formation during concentric/ eccentric drilling. *Journal of Petroleum Science and Engineering* 145 (2016) pp. 161–167.
- Hemphill, T. and Larsen, T.I. "Hole-Cleaning Capabilities of Oil Based and Water-Based Drilling Fluids: A Comparative Experimental Study," paper SPE 26328 presented at the 1993 SPE Annual Technical Conference and Exhibition, Houston, 3–6 October.
- Hirschberg, A., deJong, L.N.J., Schipper, B.A. *et al.* 1984. Influence of Temperature and Pressure on Asphaltene Flocculation. *SPEJ*. 24 (3): 283–293. SPE-11202-PA.
- Holditch, S.A. 1979. Factors Affecting Water Blocking and Gas Flow from Hydraulically Fractured Gas Wells. *J Pet Technol* 31 (12): 1515–1524. SPE-7561-PA.
- Houchin, L.R. and Hudson, L.M. 1986. The Prediction, Evaluation, and Treatment of Formation Damage Caused by Organic Deposition. Presented at the SPE Formation Damage Control Symposium, Lafayette, Louisiana, 26–27 February 1986. SPE-14818-MS.
- Hussain H. Al-Kayiem *et al.* Simulation of The Cuttings Cleaning During The Drilling Operation. *American Journal of Applied Science* 7(6), p 800–806, 2010.
- Hussaini, S.M. and Azar, J.J. "Experimental Study of Drilled Cuttings Transport Using Common Drilling Muds," *SPEJ* (Feb. 1983) 11–20.
- Israelachvili, J. 1993. *Intermolecular and Surface Forces*. New York: John Wiley and Sons.
- Iyoho, A.W. (1980), "Drilled-Cuttings Transport by Non-Newtonian Drilling Fluids Through Inclined, Eccentric Annuli," PhD dissertation, U. of Tulsa, Tulsa, OK.
- Iyoho, O.K., and Azar, J.J. (1981). An Accurate Slot Flow Model for Non-Newtonian Fluid Flow Through Eccentric Annuli. *SPEJ* (Oct. 1981) 565–72.
- Jalukar, L.S. (1993), "Study of Hole Size Effect on Critical and Subcritical Drilling Fluid Velocities in Cuttings Transport for Inclined Wellbores," MS thesis, U. of Tulsa, Tulsa, OK.
- Jiao, D. and Sharma, M.M. "Formation Damage due to Static and Dynamic Filtration of Water Based Muds" Paper SPE 23823 presented at SPE Formation Damage Control Symposium, Lafayette, LA, Feb.26–27,1992.

- Jones Jr., F.O. 1964. Influence of Chemical Composition of Water on Clay Blocking of Permeability. *J Pet Technol* 16 (4): 441–446.
- Journal of Canadian Petroleum Technology, Effect of Drilling Fluid Filter Cake Thickness and Permeability on Cement Slurry Fluid Loss, J. Griffith, Halliburton Energy Services, Inc.; S. O. Osisanya, University Of Oklahoma, Volume 38, Number 13, 1999.
- Kamath, J. and Laroche, C. 2000. Laboratory Based Evaluation of Gas Well Deliverability Loss Due to Waterblocking. Presented at the SPE Annual Technical Conference and Exhibition, Dallas, Texas, 1–4 October. SPE-63161-MS.
- Kawanaka, S., Park, S.J., and Mansoori, G.A. 1991. Organic Deposition from Reservoir Fluids: A Thermodynamic Predictive Technique. *SPE Res Eng* 6 (2): 185–192. SPE-17376-PA.
- Laboratory and Field Evaluation of a Combined Fluid-Loss-Control Additive and Gel Breaker for Fracturing Fluids, *SPE Production Engineering*, pp. 253–260, 1990.
- Larsen, T.I. (1990), “A Study of the Critical Fluid Velocity in Cuttings Transport” MS thesis, U. of Tulsa, Tulsa, OK.
- Larsen, T.I., Pilehvari, A.A., and Azar, J.J. “Development of a New Cuttings Transport Model for High-Angle Wellbores Including Horizontal Wells,” paper SPE 25872 presented at the 1993 SPE Rocky Mountain Regional/Low Permeability Reservoir Symposium, Denver, 12–14 April.
- Leontaritis, K.J. 1989. Asphaltene Deposition: A Comprehensive Description of Problem Manifestations and Modeling Approaches. Presented at the SPE Production Operations Symposium, Oklahoma City, Oklahoma, 13–14 March 1989. SPE-18892-MS.
- Li, Y., and Kuru, E. (2004). Optimization of Hole Cleaning in Vertical Wells Using Foam. SPE86927, paper presented in California, USA, March 2004.
- Lopes, R.T.; Oliveira, L.F., de Jesus, E.F.O. and Braz, D. (2001), “Analysis of Complex Structures Using a 3D X-Ray Tomography System with Microfocus Tube”, Proceedings of SPIE, Vol. 4503.
- Mahadevan, J. and Sharma, M. 2003. Clean-up of Water Blocks in Low Permeability Formations. Presented at the SPE Annual Technical Conference and Exhibition, Denver, Colorado, 5–8 October. SPE-84216-MS.
- Martin, M. *et al.* “Transport of Cuttings in Directional Wells,” paper SPE/IADC 16083 presented at the 1987 SPE/IADC Drilling Conference, New Orleans, 15–18 March.
- McClafflin, G.G. and Whitfill, D.L. 1984. Control of Paraffin Deposition in Production Operations. *J Pet Technol* 36 (11): 1965–1970. SPE-12204-PA.
- McLeod, H.O. and Coulter, A.W. 1966. The Use of Alcohol in Gas Well Stimulation. Presented at the SPE Eastern Regional Meeting, Columbus, Ohio, 10–11 November. SPE-AIME-1663-MS.
- Monger, T.G. and Fu, J.C. 1987. The Nature of CO<sub>2</sub>-Induced Organic Deposition. Presented at the SPE Annual Technical Conference and Exhibition, Dallas, Texas, 27–30 September 1987. SPE-16713-MS.



- Monger, T.G. and Trujillo, D.E. 1991. Organic Deposition During CO<sub>2</sub> and Rich-Gas Flooding. *SPE Res Eng* 6 (1): 17–24. SPE-18063-PA.
- Mungan, N. 1965. Permeability Reduction Through Changes in pH and Salinity. *J Pet Technol* 17 (12): 1449–1453. SPE-1283-PA.
- Nance, W.B. *et al.* “A Comparative Analysis of Drilling Results Obtained with Oil Mud vs. Water-Base Mud at High Island Block A-270,” paper IADC/SPE 11357 presented at the 1983 IADC/SPE Drilling Conference, New Orleans, 20–23 February.
- Narayanaswamy, G., Pope, G.A., Sharma, M.M. *et al.* 1999. Predicting Gas Condensate Well Productivity Using Capillary Number and Non-Darcy Effects. Presented at the SPE Reservoir Simulation Symposium, Houston, Texas, 14–17 February 1999. SPE-51910-MS.
- Narayanaswamy, G., Pope, G.A., Sharma, M.M. *et al.* 1999. Predicting Gas Condensate Well Productivity Using Capillary Number and Non-Darcy Effects. Presented at the SPE Reservoir Simulation Symposium, Houston, Texas, 14–17 February 1999. SPE-51910-MS.
- Nasiri, A., Ghaffarkhah, A., *et al.*, 2017, Experimental and field test analysis of different loss control materials for combating lost circulation in bentonite mud, *Journal of Natural Gas Science and Engineering*, Volume 44, August 2017, Pages 1–8.
- Neff, Jerry M. (2005): Composition, Environmental Fates and Biological Effect of Water Based Drilling Mud and Cuttings Discharged to the Marine Environment. 2005. 17p.
- Newberry, M.E. and Barker, K.M. 1985. Formation Damage Prevention Through the Control of Paraffin and Asphaltene Deposition. Presented at the SPE Production Operations Symposium, Oklahoma City, Oklahoma, 10–12 March 1985. SPE-13796-MS.
- Njaerheim, A. and Tjoetta, H. “New World Record in Extended Reach Drilling From Platform Statfjord ‘C,’” paper IADC/SPE 23849 presented at the 1992
- Nyland, T., Azar, J.J., Becker, T.E. *et al.* 1988. Additive Effectiveness and Contaminant Influence on Fluid-Loss Control in Water-Based Muds. *SPE Drill Eng* 3 (2): 195–203. SPE-14703-PA.
- Okrajni, S.S. and Azar, J.J. “The Effects of Mud Rheology on Annular Hole Cleaning in Directional Wells,” SPEDE ~Aug. 1986! 297; Trans. AIME, 285.
- Peters, F.W. and Stout, C.M. 1977. Clay Stabilization During Fracturing Treatments with Hydrolyzable Zirconium Salts. *J Pet Technol* 29 (2): 187–194. SPE-5687-PA.
- Pilehvari, A.A., Azar, J.J., and Shirazi, S.A. 1999. State-of-the-Art Cuttings Transport in Horizontal Wellbores. *SPE Drill & Compl* 14 (3): 196–200. SPE-57716-PA.
- Porter, K. E., “An Overview of Formation Damage,” *Journal of Petroleum Technology*, 41(8), 1989, 780–786.
- Raleigh, J.T. and Flock, D.L. 1965. A Study of Formation Plugging with Bacteria. *J Pet Technol* 17 (2): 201–206. SPE-1009-PA.
- Rasi, M. “Hole Cleaning in Large, High-Angle Wellbores,” paper IADC/SPE 27464 presented at the 1994 IADC/SPE Drilling Conference, Dallas, 15–18 February.

- Ravi, K.M., Beirute, R.M. and Covington, R.L. "Erodability of Partially Dehydrated Gelled Drilling Fluid and Filter Cake". SPE 24.571. 67th Annual Technical Conference and Exhibition of the Society of Petroleum Engineers, Washington, 1992.
- Rowe, M.D., Galliano, C.C., Graves, W.V.A., 2016, MEMS-lost circulation materials for evaluating fluid loss and wellbore strengthening during a drilling operation, US Patent 9488019 B1.
- Saasen, A., Løklingholm, G., and Statoil, A.S.A. (2002). The Effect of Drilling Fluid Rheological Properties on Hole Cleaning, 74558-MS
- Savari, S., Kulkarni, S.D., Whitfill, D.L., Jamison, D.E. 2015. Engineering design of lost circulation materials (LCMs) is more than adding a word. Presented at the SPE/IADC Drilling Conference and Exhibition, London.
- Schantz, S.S. and Stephenson, W.K. 1991. Asphaltene Deposition: Development and Application of Polymeric Asphaltene Dispersants. Presented at the SPE Annual Technical Conference and Exhibition, Dallas, Texas, 6–9 October 1991. SPE-22783-MS.
- Schechter, R.S. 1991. *Oil Well Stimulation*. Englewood Cliffs, New Jersey: Prentice Hall.
- Seeberger, M.H., Matlock, R.W., and Hanson, P.M.: "Oil Muds in Large-Diameter, Highly Deviated Wells: Solving the Cuttings Removal Problem," paper SPE/IADC 18635 presented at the 1989 SPE/ IADC Drilling Conference, New Orleans, 28 February–3 March.
- Sewell, M. and Billingsley, J. 2002. An Effective Approach to Keeping the Hole Clean in High-Angle Wells. *World Oil* 223 (10): 35.
- Sharma, B.G. and Sharma, M.M. 1994. Polymerizable Ultra-Thin Films: A New Technique for Fines Stabilization. Presented at the SPE Formation Damage Control Symposium, Lafayette, Louisiana, 7–10 February 1994. SPE-27345-MS.
- Sharma, M.M. and Wunderlich, R. 1987. Alteration of Rock Properties Due to Interaction with Drilling Fluid Components. *J. Petroleum Science and Engineering* 1: 127.
- Sifferman, T.R. and Becker, T.E.: "Hole Cleaning in Full-Scale Inclined Wellbores," SPEDE ~June 1992! 115; Trans., AIME, 293.
- Smith, T.R and Ravi, K.M. "Investigation of Drilling Fluid Properties to Maximize Cement Displacement Efficiency". SPE 22775, 66th Annual Technical Conference and Exhibition of the Society of Petroleum Engineers, Dallas, 1991.
- Standing, M.B. (1970). Inflow Performance Relationships for Damaged Wells Producing by Solution-Gas Drive. *J Pet Technol* 22 (11): 1399–1400. SPE-3237-PA.
- Stangeland, H., 2015, Experimental Lost Circulation and Performance Simulation Studies of 60/40, 70/30, 80/20 and 90/10 OBMs, MSc Thesis, Faculty of Science and Technology, University of Stavanger, Norway.
- Stevenic, B.C.: "Design and Construction of a Large-Scale Wellbore Simulator and Investigation of Hole Size Effects on Critical Cuttings Transport Velocity in Highly Inclined Wells," MS thesis, U. of Tulsa, Tulsa, OK, 1991.

- Tannich, J.D. 1975. Liquid Removal from Hydraulically Fractured Gas Wells. *J Pet Technol* 27 (11): 1309–1317. SPE-5113-PA.
- Thomas, D.C. 1988. Selection of Paraffin Control Products and Applications. Presented at the International Meeting on Petroleum Engineering, Tianjin, China, 1–4 November 1988. SPE-17626-MS.
- Tomren, P.H., Iyoho, A.W., and Azar, J.J.: “Experimental Study of Cuttings Transport in Directional Wells,” *SPEDE*, Feb. 1986, 43. 5.
- Tomren, P.H., Iyoho, A.W., and Azar, U.: “Experimental Study of Cuttings Transport in Directional Wells,” *SPEDE* (Feb. 1986) 43–56.
- Tomren, P.H. “The Transport of Drilled Cuttings in an Inclined Eccentric Annulus,” MS thesis, U. of Tulsa, Tulsa, OK (1979).
- Van der Bas, F., *et al.*: “Radial Near Well Bore, Stimulation by Acoustic Waves,” SPE 86492, Presented at The SPE International Symposium on Formation Damage and Control, February 18–20, 2004.
- Vanpuymbroeck, L. (2013). Increasing Drilling Performance Using Hydro-Mechanical Hole Cleaning Devices. SPE 164005 paper presented in Muscat, Oman, 28–30 January 2013.
- Vogel, J.V. (1968). Inflow Performance Relationships for Solution-Gas Drive Wells. *J Pet Technol* 20 (1): 83–92.
- Wærnes, K., 2013, Applying Dual Gradient Drilling in complex wells, challenges and benefits, MSc Thesis, Faculty of Science and Technology, University of Stavanger, Norway.
- Wong, S.W. *et al.* “High Power/High Frequency, Acoustic Stimulation- A Novel an Effective Wellbore Stimulation Technology”, Paper SPE 84118, presented at The Annual Technical Conference and Exhibition, Denver Colorado, Oct 5–8, 2003.
- Yan, J. and Sharma, M.M. 1989. Wettability Alteration and Restoration for Cores Contaminated with Oil Based Muds. *J. Petroleum Science and Engineering* 2 (2): 63.
- Yan, J.-N., Monezes, J.L., and Sharma, M.M. 1993. Wettability Alteration Caused by Oil-Based Muds and Mud Components. *SPE Drill & Compl* 8 (1): 35–44. SPE-18162-PA.
- Yen, T.F. 1974. Structure of Petroleum Asphaltene and Its Significance. *Energy Sources* 1 (4): 447.
- Zain, Z.M. and Sharma, M.M. 1999. Cleanup of Wall-Building Filter Cakes. Presented at the SPE Annual Technical Conference and Exhibition, Houston, Texas, 3–6 October 1999. SPE-56635-MS.
- Zhou, L. (2008). Hole Cleaning During Underbalanced Drilling in Horizontal and Inclined Wellbore. IADC/SPE98926, paper presented in September 2008.

# 4

## Problem Related to Drilling Hydraulics

### 4.0 Introduction

Hydraulics can be defined as a study of the physical science and technology of the static and dynamic behavior of fluids under the influence of mechanical forces and/or pressure, and uses of that knowledge in the designing and controlling of machines. In drilling engineering, drilling hydraulics is an essential part of drilling operations where computation of pressure profiles along the wellbore and particularly in the annulus contributing to well safety and well integrity are done to improve the API recommended practice for drilling fluid rheology and drilling hydraulics estimation. Drilling hydraulics play a vital role while drilling activities continue to operate which is also referred to as rig hydraulics.

In the petroleum industry, the drilling hydraulics plays the role of an engine. The hydraulic system accounts for the frictional loss in the entire system, the drill bit movement, and the overall sustenance of drilling. A well-maintained hydraulic system is essential to keeping the drilling rig running efficiently. It is far more productive to prevent breakdowns through regular maintenance than to deal with the downtime and increased cost

associated with hydraulic system failures. The emphasis should therefore be on proactive, rather than reactive, maintenance.

A proactive process involves preventative maintenance, which itself requires a clear understanding of the equipment's operating conditions. As we will see in later chapters, no hard and fast rules can be established for the hydraulic system as the variability of different locations is great and a custom-designed scheme must be implemented. After that, it is desirable to have a frequent maintenance scheme that will increase the duration of smooth drilling operations. In this process, important factors to consider are: (i) duration of the rig operating per day and per week, (ii) percentage of time that the system is operating at maximum flow and pressure, (iii) environmental and climatic conditions, including extreme heat, cold, wind, presence of debris and dust, humidity, (iv) properties of fluids that are being used (in the form of mud, spacers, cement, etc.), (v) rate of penetration (ROP), and (vi) rock properties.

These factors will help follow the guidelines of the various manufacturers and optimize operating conditions. It is also desirable to develop industry's own maintenance program that can be followed by all personnel, with a clear log of maintenance activities and note of any anomalies noticed.

Some key components of the hydraulic system are: (i) hydraulic fluid filter, (ii) hydraulic tank, (iii) air breather, and (iv) hydraulic pump. Routine maintenance on these components includes replacing the filter, cleaning the inside and outside of the hydraulic tank, checking and recording hydraulic pressures and flows, and inspecting hydraulic hoses and fittings. The drilling rig manufacturer's equipment manual should include hydraulic circuit diagrams. Being able to read and understand these diagrams is vital for performing maintenance and troubleshooting.

A proper drilling operation includes planning based on hydraulics calculations, and optimization of ROP. The ROP is considered to be one of the prime factors in drilling a petroleum well and it is therefore given prime consideration when drilling an oil well.

Proper considerations of hydraulics will help with selection of bit nozzles and drill bits, estimate frictional pressure drops through the drillpipe and various surface equipment, develop efficient cleaning ability of the drilling system, and proper utilization of mud pump horsepower. An incorrect design resulting in an inefficient hydraulics system can: i) slow down the ROP, ii) fail to properly clean the hole of drill cuttings, iii) cause lost circulation, and finally, iv) lead to blowout of the well. Inadequate hole cleaning can lead to a number of problems, including hole fill, packing off, stuck pipe, and excessive hydrostatic pressure. Drill cuttings in the hole cause wear and tear of the drillstring and also reduce the rate of penetration,

thereby increasing the cost and time for drilling. Hence, there is a need to design a system that will efficiently remove the drill cuttings, transport them to the surface in a cost-effective manner, prepare an appropriate drilling mud and maximize the hydraulic horse power at the drill bit.

As a result, proper design and maintenance of rig hydraulics is crucial. To understand and properly design the hydraulic system, it is important to discuss hydrostatic pressure, types of fluid flow, criteria for type of flow, and types of fluids commonly used in the various operations at the drilling industry. Hence, this chapter deals with the type of fluids; pressure losses in the surface connections, pipes, annulus, and the bit; jet bit nozzle size selection; surge pressures due to vertical pipe movement; optimization of bit hydraulics; and carrying capacity of drilling fluid.

This chapter will address those problems and propose the solutions. Case studies are presented in order to show relevance of the chapter to field applications.

## **4.1 Drilling Hydraulics and its Problems and Solutions**

Hydraulic oil accomplishes two essential functions: lubrication and transmission of power. It is the lifeblood of the hydraulic system and it must be kept clean if the entire system is to operate properly. Precision parts are very vulnerable to the effects of contamination and debris. Any malfunction in any of the hydraulic components can be magnified causing bigger problems for the drilling operation. Contaminated hydraulic fluid causes wear, which can create leaks and cause heat to build up in the system. In turn, heat can decrease the lubricating properties of the hydraulic fluid and cause further wear, thus snowballing the problem. Another source of difficulty is aeration or the formation of air in a hydraulic system. This can cause leaks and turbulence or vibration, which increases component wear and loss of efficiency. Contamination of the funnel or container that has previously had other types of fluids and lubricants can also become a source of problems to the hydraulic system.

If a hydraulic pump or motor does fail, the system can become contaminated by particles and debris from the damaged unit. While the component must be removed and repaired, this is often not the greatest expense. The tank must be drained, flushed and cleaned. All hoses, lines, cylinders and valves should be inspected for wear and debris. All components of the entire system should be flushed to remove any particles. Finally, filters should be replaced, the hydraulic fluid that was drained from the system

disposed of and the tank filled with clean hydraulic fluid. All of this downtime and expense can generally be avoided by following a schedule of preventative maintenance.

Understanding the drilling problems and their causes, and planning solutions are necessary to avoid very costly drilling problems and successfully achieving the target zone. Many of these problems can be traced back to hydraulics problems. Table 4.1 briefly describes most of the dominant forms of the failures that occur during the drilling process of wellbore and reasons (or working conditions) causing these failures, emerging from malfunction in the hydraulic system.

Wang *et al.* (2011) reported 130 cases of drilling failures in the northeast Sichuan region of China. The failures were characterized in various categories, namely, drillstring failure, the frequency of drillstring failure, failure position of drillstring, and drilling depth. Figure 4.1 plots the number of failures versus the forms of failure. It can be seen that 65% of the failure is fracture, 23% is washout, and only 8% is twist-off. Fracture and washout are the major failure forms encountered during the drilling operations in northeast Sichuan (China). Figure 4.2 shows the number of failures dependent on drillstring position. In Figure 4.2, DPB refers to drillpipe body, DCB drill collar body, TC threaded connections, SA shock absorber, and DB drill bit (From Wang *et al.*, 2011). As shown in Figure 4.2, 39% of the failures occur on drillpipe body, 24% of the failures on drill collar body, 14% on threaded connection, and 23% of the failures on other positions of drillstring such as shock absorber and drill bit. Figure 4.3 depicts the variation of number of failures with drilling depth. It can be observed that the drillstring failure has higher frequencies of occurrence at depth range of 1250–2750 m and 4750–5750 m. Fracture is the major failure form at depth of 0–3000 m and mainly caused by fatigue. In comparison, washout is found to be the major failure form at depth range of 4500–5500 m and corrosion is considered as the chief contributing factor that causes failure. Picture 4.1 shows the observed forms of drillstring failure in northeast Sichuan (China). As can be seen from Picture 4.1, the three major forms of fracture failure of drillstring are (i) fatigue failure, (ii) washout due to corrosion, and (iii) fracture due to hydrogen embrittlement.

The following causes of the failure were identified:

1. The drillstring continuously undergoes various stresses including tension, compression, bending, and twisting in the wellbore due to complex geological conditions of the drilled formations.

**Table 4.1** Types of problems that can be related to the hydraulics (Albdiry and Almensory, 2016).

Failure modes	Reasons causing these failures	Remarks
Fatigue failure	<ul style="list-style-type: none"> <li>• Fluctuated weight</li> <li>• Repeated rotational speeds (loads or torque)</li> <li>• High penetration rate of the drillstring</li> </ul>	Fatigue failure occurs due to a high stress concentration in the thread roots connections and a high stress concentration at the upset transition area of the drillpipe.
Axial vibrations	The drillstring moves along its axis of rotation	It is essentially operating the drillstring above or below the critical speed and performing pre-drilling analysis and real time analysis of the drillstring dynamics to reduce the vibrations and the probability of a premature failure of the downhole
Torsional vibrations	An irregular rotation of the drillstring rotated from the surface at a constant speed	
Lateral vibrations	The drillstring moves laterally to its axis of rotation	
Buckling in the drillpipe	Bending stress	Over time the bending stress causing the buckling loads to the occurrence of fatigue failure of the drill pipe
Wash out and Twist-off failure in the drillpipe	<ul style="list-style-type: none"> <li>• Mechanical fatigue damage or corrosion</li> <li>• A large pressure of the drilling mud</li> </ul>	The washout is a leak, crack or a small opening in the drillpipe Twist-off is a post-separation catastrophic failure to the fracture surface of the drill pipe
Pipe sticking Pipe-parting	<ul style="list-style-type: none"> <li>• The induced tensile stress exceeds the pipe-material ultimate tensile stress</li> </ul>	The stabilizers are normally used to reduce the drillstring vibration and improve the wellbore stability and optimize the well placement for faster production in the borehole enlargement operations.
Collapse and Burst failure	<ul style="list-style-type: none"> <li>• Poor pipe handling practices</li> </ul>	-
Tooth loss	Severe repeated impact and rotation	

(Continued)



Table 4.1 Cont.

Failure modes	Reasons causing these failures	Remarks
Tooth fracture	<ul style="list-style-type: none"> <li>• The impact spalling where the failed teeth contain many different sizes of spalling pits, and grooves linked together by spalling bits</li> <li>• The crack extensions around the spalling pits formed due to growing of the grooves deeper and wider can also result in tooth fracture and local spalling</li> </ul>	The tooth generates fatigue cracks and this would tend to a tooth fracture
Tooth wear	<ul style="list-style-type: none"> <li>• When a compressive stress on the joint surfaces between the tooth and the abrasive particle exceeds the breaking strength of the abrasive particles</li> <li>• When a tooth surface encounters sharp edges or protrusions, the tooth scrapes happen easily</li> </ul>	A stress concentration will be generated on these joints surfaces which tend to continually crush the abrasive particles. The stress concentration will work to increase the fatigue damage on the tooth surfaces. The scouring effect, or the compressed air mixed with large amount of the hard cuttings flows over the tooth surfaces increases the abrasive wear on the tooth surfaces.
Bit balling	<ul style="list-style-type: none"> <li>• Sticking of drill cuttings on the bit surface in water-reactive clay/shale formations</li> <li>• Inappropriate bit choice or bit wear</li> <li>• Poor bit hydraulics or low flow rate</li> </ul>	Factors affecting the bit balling sticking are: <ul style="list-style-type: none"> <li>• Clay calcite content</li> <li>• High weight on bit, and</li> <li>• Poor projection of bit cutting structure</li> </ul>
Wellbore instability	<ul style="list-style-type: none"> <li>• Properties of the drilling mud and its interaction with the formation</li> <li>• Mechanical properties of the formation</li> <li>• Magnitude and distribution of the forces around the wellbore</li> </ul>	Sloughing or swelling shales and abnormal pressured shale formations are also affected the wellbore instabilities
Wellbore sliding/shear failure	Mud weight along borehole trajectories, and drilling orientations.	-

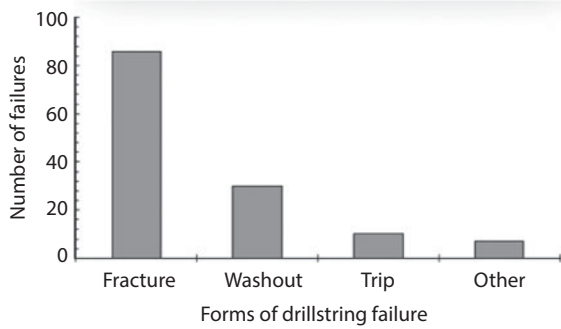

Figure 4.1 Number of failures versus forms of failure (From Wang *et al.*, 2011).

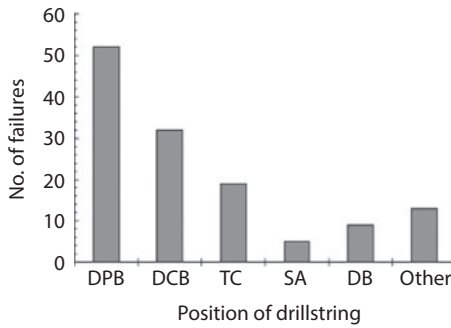

Figure 4.2 Number of failures versus the position of drillstring.

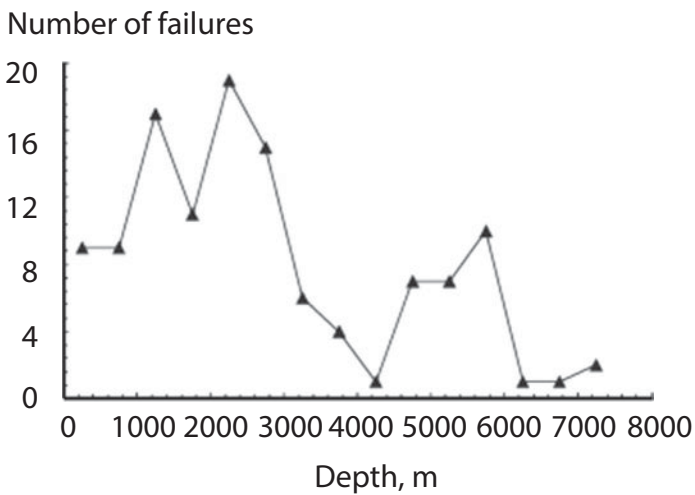

Figure 4.3 Number of failures versus drilling depth (From Wang *et al.*, 2011).



**Picture 4.1** Photos of typical drillstring failure: (a) fatigue fracture of drillstring caused by gas drilling; (b) fracture surface of drillstring; (c) the washout of drillstring due to corrosion; (d) fracture of drillstring due to hydrogen embrittlement. (From Wang *et al.*, 2011).

2. The application of air drilling technology exacerbates the vibration of the drillstring since the damping effect of drilling fluid on the drillstring is removed in the air drilling process.
3. Poor quality of drillstring results in premature failure of the drillstring. For example, the manufacturing defects on the drillstring may lead to uneven propagation and distribution of stresses, which is detrimental to maintaining of drillstring strength.
4. Drillstring strength deteriorates due to the electrochemical reaction with the high concentration of hydrogen sulfide, carbon dioxide and other corrosive fluids that escape from the drilled formations.
5. When drillstring sticking is encountered, improper anti-sticking measures, such as overpulling and overpushing of

drillstring, may result in fatigue or rupture of drillstring due to the extra-large tensile or compressive stress acting on drillstring.

6. The anti-failure performance of drillstring can be compromised as a result of unscientific design or design faults.

Note most of these causes originally trace back to a hydraulics problem. As can be seen from later chapters, each cause calls for an entire chapter on individual malfunctions.

#### 4.1.1 Borehole Instability

As stated in the previous section, the hydraulic system is akin to the engine of a vehicle. Even though the borehole instability appears to be a rock mechanics problem, the instability of the system emerges from the hydraulic system. As such, the mechanism of wellbore instability is discussed here, whereas actual problems and solutions are discussed in Chapter 9 of this book.

Wellbore stability is defined as “the prevention of brittle failure or plastic deformation of the rock surrounding of the wellbore due to mechanical stress or chemical imbalance”. It is also called borehole stability, wellbore stability, and hole stability. So, borehole instability is the undesirable condition of an open hole interval that does not maintain its gauge size and shape and/or its structural integrity. Wellbore instability occurs because: (i) the creation of a circular hole into an otherwise stable formation, (ii) the hole tends to collapse or fracture unless supported, (iii) some rocks are very strong and will support themselves better than weaker rocks. Borehole instability appears as (i) hole pack off, (ii) excessive reaming, (iii) overpull, and (iv) torque and drag. This type of problems lead to the need for extra time to continue to drill, and development cost increases significantly.

Wellbore stability is affected by properties of the drilling mud and its interaction with the formation, by the mechanical properties of the formation and by the magnitude and distribution of the forces around the wellbore (Zeynali, 2012; Cheng *et al.*, 2011). Any change in the mud system as well as the formation will affect the wellbore stability. This is unavoidable because the system is highly transient. In the presence of shales, sloughing or swelling shales can occur. Also, shales under abnormal pressures are also vulnerable to wellbore instabilities (Akhtarmanesh *et al.*, 2013).

The main mechanisms of the shale instabilities i.e., the pore pressure transmission and chemical osmosis, were investigated by Akhtarmanesh *et al.* (2013) in order to evaluate their significance in the wellbore stability with respect to the physical and chemical properties of the shale and

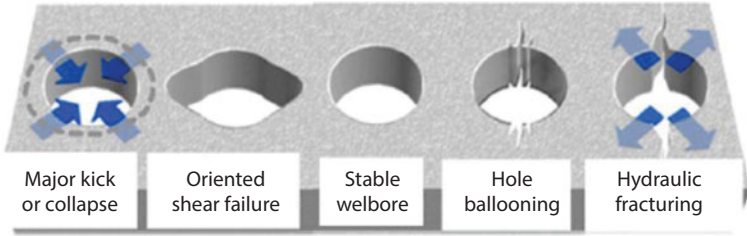

**Figure 4.4** Schematic showing borehole failures in relation to the mud pressure (Zhang, 2013).

thermodynamics condition. It was revealed that the shale formations can cause many problems such as partial or huge slump, which in turn results in pipe sticking or poor hole conditioning, bit balling and bit floundering as well as low quality logging and drilling fluid contamination due to its mixing with dispersed active clay particles. Zhang (2013) calculated the borehole failures, wellbore sliding/shear failures in relation to the mud weight along borehole trajectories with various drilling orientations versus bedding planes (Figure 4.4). As can be seen from Figure 4.4, rock anisotropy will affect horizontal stresses. This fact was considered by Zhang (2013).

Borehole instabilities lead to two types of problems, namely, tight hole and stuck pipe incidents, which are potentially dangerous and caused by the hole collapse (rock mechanical failure), inappropriate hole cleaning, differential sticking, and deviation from ideal trajectory.

Figure 4.5 shows the types of borehole instability which introduces some other drilling problems such as sand production, lost circulation, stuck pipe, breakthrough, hole collapse, uncontrolled fracturing, and casing failure. The reasons of borehole instability can be categorized as: (i) mechanical failure by in-situ stresses, (ii) erosion due to drilling fluids, and (iii) chemical due to the interaction of fluids and formations. In general, there are four types of borehole instabilities. These are recognized as: (i) hole enlargement, (ii) hole closure, (iii) fracturing, and (iv) collapse.

#### 4.1.1.1 Hole Enlargement

In certain cases of wellbore instability, hole enlargement can occur. Chapter 9 presents the whole range of problems related to hole enlargement, whereas this section discusses the relevance of the problem to drilling hydraulics.

It is also recognized as washout because the hole becomes undesirably larger than expected. In general, most boreholes enlarge over time. Therefore,

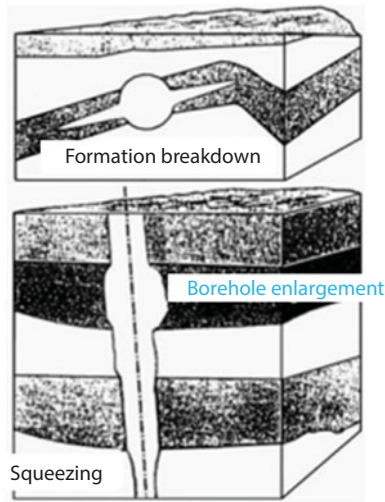

Figure 4.5 Types of borehole instabilities.

it is called a time-dependent collapse phenomenon. Hole enlargement is indirectly connected to lateral vibrations. It should be known that drillstring vibrations could lead to irreparable damage to the borehole, when having sufficient lateral amplitude to hit the wall. Vibrations can lead to large fractured areas, resulting in rock blocks falling into the well. In severe cases vibrations can lead to instability problems. When drilling through hard formations, the chemical interaction between the drilling fluid and the rock should be excluded as a cause of wellbore instability. When the drillstring hits the wellbore wall, enlargements will be created and the measurement while drilling (MWD) equipment may be destroyed. Vibrations are measured as accelerations, with sensors placed in a sub near the bit. Accelerations are measured in g's, where 1g is the earth's gravitational acceleration. The lateral accelerations can reach 80g's in harsh environments and in severe cases 200 g's has been recorded. In an operation experiencing 80g's, using a drill collar with 223 kg/m (150 lb/ft) of mass, the lateral force exerted by 0.3048 m (1ft) of drill collar will be 5.41 tons (11927lb). Five tons acting on the formation will naturally cause significant damage to the wellbore wall. When lateral vibrations are present, the drillstring will hit the wellbore wall repeatedly, impacting the wall multiple times. The number of times the drillstring hits the borehole, as well as the magnitude of the impact force will affect the wellbore stability and downhole conditions.

Hole enlargement introduces problems such as: (i) difficulties in removing rock fragments and drilled cuttings from the borehole, (ii) an increase

in possible hole deviation, (iii) an increase in potential problems during logging operation, and (iv) reduced quality of the cement placement behind casing string. It is caused by hydraulic erosion, mechanical abrasion due to drillstring, and inherently sloughing shale.

#### 4.1.1.2 Hole Closure

It is also recognized as narrowing because the hole becomes undesirably narrower than expected. Occasionally it is referred to as a creep under the overburden pressure. Hole closure is a time-dependent phenomenon of borehole instability. At large, it appears in plastic-flowing shale, and salt sections. Hole closure introduces the problems such as: (i) an increase in torque and drag, (ii) an increase in potential pipe sticking, (iii) an increase in the difficulty of casing landing.

#### 4.1.1.3 Fracturing

While drilling, fracturing can take place if the wellbore mud pressure exceeds the formation-fracture pressure (Figure 4.6). Figure 4.6 (a) shows the general configuration of the fracture profile, whereas Figure 4.6(b) shows the casing settings within the general configuration. If the mud window is not properly maintained, the associated problems due to fracturing are possibility of kick occurrence, and loss circulation.

#### 4.1.1.4 Collapse

Borehole collapse occurs when the drilling-fluid pressure is too low to maintain the structural integrity of the drilled hole. The associated problems are the pipe sticking, and possible loss of well. As such the actual discussion of the problems and their solutions are presented in a different chapter (Chapter 6).

It is a shear type wellbore failure. This failure happens when the wellbore pressure is low. If the borehole pressure is low, the tangential stress becomes large enough for failure to occur. As a result, rock fragments fall off into the wellbore and thus form an elliptic borehole shape. Aadnoy and Kaarstad (2010) developed models to predict the elliptic shape of the borehole when equilibrium is obtained. Applying the Mohr-Coulomb failure model, the critical collapse pressure is given by these equations:

$$\sigma_A = (1 + 2c)\sigma_H - \sigma_h - \left(\frac{2}{c} - 1\right)P_w \quad (4.1)$$

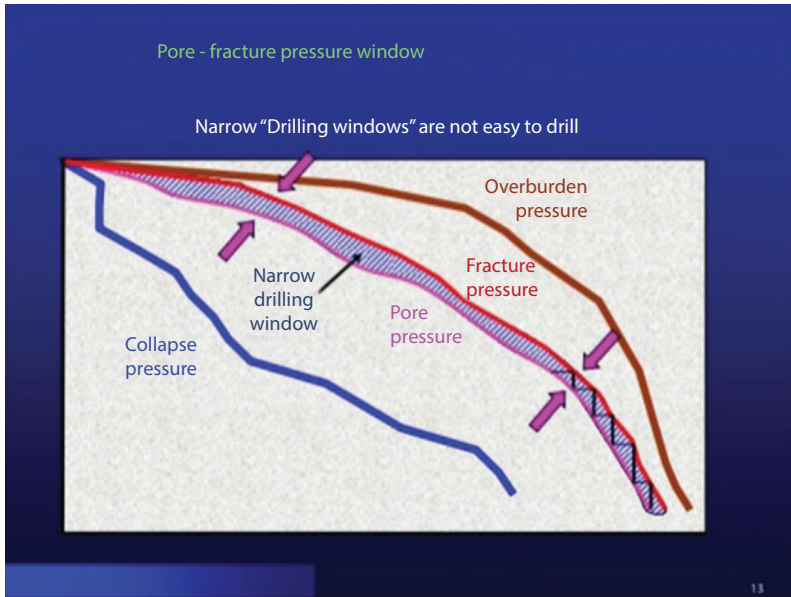

(a)

### Plot Pressure Window

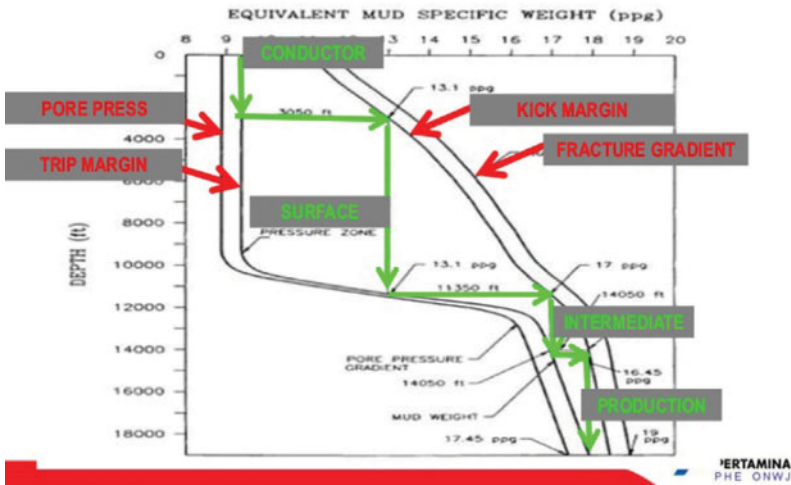

(b)

Figure 4.6 Drilling windows showing pore and fracture gradients.

$$\sigma_B = \left(1 + \frac{2}{c}\right) \sigma_H - \sigma_h - (2c - 1)P_w \tag{4.2}$$



The borehole is considered stable when the tangential stress is uniform around the ellipse. Thus, the tangential stresses in points A and B are equal. Setting Eq. 4.1 equal to Eq. 4.2 gives:

$$C = \frac{b}{a} = \frac{\sigma_h + P_w}{\sigma_H + \sigma_w} \quad (4.3)$$

$$\frac{1}{2}(\sigma'_1 - \sigma'_3) \cos \theta = \tau_0 + \left\{ \frac{1}{2}(\sigma'_1 + \sigma'_3) - \frac{1}{2}(\sigma'_1 - \sigma'_3) \sin \theta \right\} \tan \theta \quad (4.4)$$

where  $\sigma'$  is the effective stress defined by  $\sigma' = \sigma - P_0$ . During inflow to the wellbore, the pore pressure at the borehole wall is equal to the wellbore pressure.

$$\sigma'_3 = P_w - P_0 = 0 \quad (4.5)$$

Equation 4.4 can be written by applying the Eq. 4.5 as:

$$\sigma'_1 = 2\tau_0 \frac{\cos \theta}{1 - \sin \theta} \quad (4.6)$$

If conditions exist such that shear stresses diminish so that  $\sigma_H = \sigma_h$ ,  $\theta = 0^\circ$ , or  $\gamma = 0^\circ$ , the maximum principal stress becomes:

$$\sigma_1 = \sigma_\theta = \sigma_A \quad (4.7)$$

Because collapse will take place at point A when the initial condition is a circular hole. Inserting equations (4.1) and (4.6) into equation (4.7) and solving for  $c$  yields:

$$c^* = \frac{-Y + \sqrt{Y^2 - 4XZ}}{2X} \quad (4.8)$$

where

$$X = \sigma_H$$

$$Y = \sigma_H - \sigma_h + P_w - P_0 - 2\tau_0 \frac{\cos \theta}{1 - \sin \theta}$$

$$Z = -2P_w$$

Equation (4.8) defines the ellipse obtained when both the cohesion strength ( $\tau_0$ ) and friction angle ( $\theta$ ) are different from zero. Thus, the ellipse defined by Equation (4.8) is less oval than the ellipse defined by Equation (4.3). This solution is valid only when the wellbore pressure matches the pore pressure at the wellbore wall, e.g., when drilling underbalanced in a permeable formation.

In the general case where  $P_w \neq P_0$  Equation (4.4) may be solved for the major effective horizontal stress,  $\sigma'_1$

$$\sigma'_1 = 2\tau_0 \frac{\cos \varphi}{1 - \sin \varphi} + (P_w - P_0) \frac{1 + \sin \varphi}{1 - \sin \varphi} \quad (4.9)$$

Now, combining equations (4.1) and (4.9) into equation (4.7) and solving for  $\sigma_H$  yields:

$$\sigma_H = \frac{1}{(1 + 2c)} \left\{ \sigma_h + 2\tau_0 \frac{\cos \theta}{1 - \sin \theta} + (P_w - P_0) \frac{2 \sin \varphi}{1 - \sin \varphi} + \frac{2}{c} P_w \right\} \quad (4.10)$$

Solving eq. (4.10) for the wellbore collapse pressure yields:

$$P_{wc} = \frac{c}{1 - (1 - c) \sin \varphi} \left\{ \frac{1}{2} [(1 + 2c) \sigma_H - \sigma_h] (1 - \sin \varphi) - \tau_0 \cos \varphi + P_0 \sin \varphi \right\} \quad (4.11)$$

Equation (4.11) is valid for a vertical well subjected to the two normal horizontal stresses with an elliptical hole geometry. Furthermore, the solution is valid for all cases where the pore pressure in the wellbore wall differs from the wellbore pressure. Specifically (i) in all situations where the rock is impermeable such as in shales. Both overbalance, balanced and underbalance situations should use this solutions. It could also be used in other tight rocks such as unfractured chalks or carbonates, and (ii) in permeable rocks, the solution is valid for overbalanced drilling. When the wellbore pressure equals the pore pressure a simplification applies as discussed below. For underbalanced drilling a flow from the formation to the wellbore will arise.

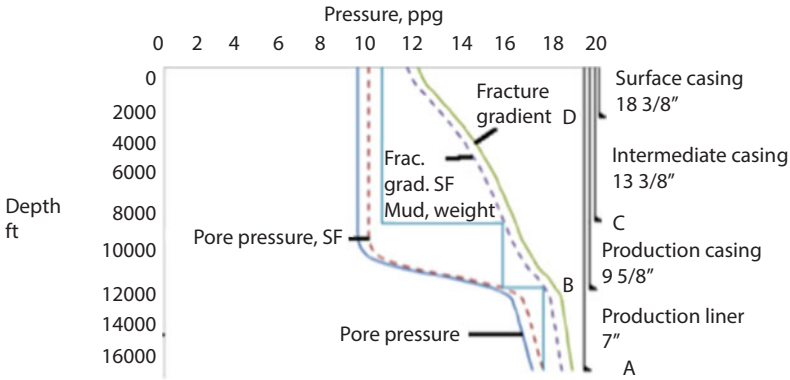

Figure 4.7 Mud Window with trip margin and correlating Well Design.

4.1.1.5 Prevention and Remediation

It is often considered that the prevention of borehole instability is unrealistic because restoring the physical and chemical in situ conditions of the rock are impossible. The process of drilling is a source of great instability and it suffices to minimize instability, so that the problem doesn't snowball into a tangible drilling problem.

Borehole stability technology includes chemical as well as mechanical methods to maintain a stable borehole, both during and after drilling. The following measures can be taken in order to minimize the impact of borehole instability.

1. Proper selection and maintenance of mud weight. When designing a well, it is common to start with the supposedly last section to be drilled. Mud weight equivalent to the pore pressure gradient at a point A on Figure 4.7 is chosen to prevent inflow from the formation, i.e., a kick. This mud density cannot be used to drill the whole well. At point B on Figure 4.7, the formation will have a fracture gradient equivalent to this weight. The intermediate casing will protect the formation at this point and to the surface from the pressure exerted on it from the mud. The intermediate casing therefore has to extend at least to point B. Then the mud density needed to drill to point B and set the intermediate casing is chosen equivalent to the fluid density shown in point C. Choosing mud density at point C implies that the surface casing has to be set at point D to avoid fracturing the formation. All points

**Table 4.2** Data for casing and corresponding depth.

Casing size (in.)	Depth, ft
7	16,500
9 5/8	12,000
13 3/8	8500
18 5/8	350

are if possible chosen on the safety margin line. Protection of fresh water aquifers, lost circulation zones, salt beds and low pressure zones which may cause stuck pipe are factors that need to be taken into consideration and influence the setting depth. Setting depths obtained by using the method described above are shown in Table 4.2.

#### 4.1.2 Proper Hole Trajectory Selection

Chapter 10 presents the entire range of problems related to hole trajectory. However, in this section, we focus on relevant aspects for this chapter. Hole trajectory is intricately linked to subsurface lithology. Petroleum exploration and production are inherently risky activities, the most important one being determination of hole trajectory. Uncertainties in determining target depth and lateral position are combined with an inability to predict small-scale features, such as minor and subseismic faults. Even though tremendous progress has been made in visualizing the subsurface, proper characterization continues to elude us. Typically, various geological and structural scenarios are run to visualize the uncertainties associated with input data, such as differing formation dips and introduction of potential faults. The trajectory being a function of mud weight as well as rock properties, only real-time monitoring and adaptation can ensure implementation of proper hole trajectory. The geological uncertainty related to the reservoir geometry and the distribution of petrochemical properties has the most direct effect on the different forecasts of the hole trajectory. Following are some of the sources of uncertainty regarding hole trajectory:

1. Uncertainty about the pore and fracture pressure, which may lead to kicks, circulation losses and stuck pipe;
2. Measurement errors, which might to lead to a chain of malfunctions of the hydraulic system;

3. Uncertainty about the actual behavior of the rock and fluid when subjected to external stimuli.

The following factors play a role:

1. Compatible borehole fluid with the formation being drilling;
2. Time spent in open hole;
3. Availability of offset well data (utilization of the learning curve);
4. Changes in torque, circulating pressure, drag, fill in during tripping, etc.

### 4.1.3 Drill Bit Concerns

Drill bits are the most important component of a drilling process. There are three types of drill bits: drag bits, roller cone bits, and diamond bits. Each type of drill bit will have a different set of fluid profile to be considered by the hydraulic system. Although drilling fluid is more often used to remove the hard drilled cuttings and circulate through passageways in the bit and consequently lengthening the bit's life, there are many parameters that could determine the function of the drilling bits and their life. Each of these functions is connected to the hydraulic system. These functions are: (i) drillstring rotations per minute (RPM), (ii) weight on bit (WOB), (iii) properties of the mud, (iv) hydraulic efficiency, and (v) severity of the dogleg.

The hydraulic power across the drill bit needs to be maximized at the point of contact between the drill bit and the formation so as to provide enough jet impact force to transport the cuttings during the drilling operation. It involves efficient removal of cuttings and transporting them through the annulus by minimizing power loss in the mud circulatory system so as to have adequate hydraulic horsepower across the drill bit.

#### 4.1.3.1 Bit Balling

Chapter 2 presented the entire set of problems and solutions of bit balling. In this section, we present aspects relevant to this chapter. Bit balling is a failure that occurs due to sticking of drill cuttings on the bit surface in water-reactive clay/shale formations. There are two mechanisms of bit balling sticking: (i) mechanical, and (ii) electrochemical. There are numerous factors affecting the bit balling sticking, such as (i) clay calcite content, and (ii) highly reactive clays with large cation exchange capacities promoted by a high hydrostatic pressure of borehole ranging from 5000 to 7000 psi.

Bit balling is also affected by (i) high weight on bit, (ii) poor projection of bit cutting structure due to inappropriate bit choice or bit wear, and (iii) poor bit hydraulics or low flow rate. Hence, anti-balling coating is the best solution to combat the bit balling. A metallic layer with highly specialized properties covers the bit surface and leads to a smoothening of the surface and elimination of the bit balling since the rough surface of the bit will increase the surface area and increase the adhesive forces.

Luo *et al.* (2016) designed a newly structured drill bit for a reverse circulation downhole air hammer in an attempt to reduce the bit balling. For this purpose, three optimized drill bits having two mid-pressure restoring grooves with a diameter of 8 mm; two symmetrically placed flushing nozzles with a diameter of 3 mm and six uniformly distributed suction nozzles with a diameter of 6 mm for each layer were built. Failure analysis of chrome coated drilling bit under a variety of drilling fluid characteristics upon circulation and influxes was studied by Ranjbar and Sababi (2012). They also studied the effects of working parameters i.e., bottom hole temperature and solid content on the bits' lifetime. It was observed that various types of damages such as scratches, coated layer detachment, deep and shallow cuttings as well as spalling pits, micro and macro-cracks occurred on the chrome coated surface.

#### 4.1.4 Hydraulic Power Requirement

The power involved in the mud circulating system includes the power needed to drive the mud pump that in turn imparts fluid power necessary to create a jet impact force through the nozzles of the drill bit. The fluid hydraulic horsepower and the bit hydraulic horsepower are the main design parameters for an effective hydraulic program, which is responsible for effective bottom hole cleaning and rate of penetration. The main component of a hydraulic system is the mud pump at the surface, the surface connection, the drillpipe, the drill collars, the drill bit, and mud tank at the surface.

Hydraulic power is defined as the product of pressure and the corresponding flow rate (Azar and Samuel, 2007):

$$H_h = P \cdot Q \quad (4.1)$$

where,

- $H_h$  = hydraulic horsepower (hp)
- $P$  = pressure
- $Q$  = flow rate

This power needs to be spent for the following activities:

1. **Surface Connection Pressure Drop:** In the mud circulation system, the first pressure drop is experienced in the surface equipment. The surface equipment of a drilling rig includes the standpipe, rotary hose, swivel wash pipe, along with the gooseneck and Kelly bushing. The pressure drop in the surface connection is substantial during drilling fluid circulation and this loss depends on the type of surface connection. Currently available calculations techniques do not allow for fluid viscosity to be counted in determining pressure loss in surface connections. Various components are classified in four different classes and are assigned specific coefficient values that are independent of fluid viscosity.
2. **Drillstring Pressure Drop:** After the drilling fluid passes through the surface connection it flows through the drillstring. As the drilling fluids flow through the drillpipe, the drill collar, and joints, pressure loss occurs. The flow is made deliberately turbulent in order to make the cement-mud and cement-spacer interface appear piston-like. This also means a high-pressure loss is allowed. The pressure drop in the drillpipe and the drill collar can be calculated for laminar and turbulent flow criteria depending on the drilling fluid type used. The types of fluids considered are:
  - a. *Newtonian fluid:* although this one is popular, it's not useful other than for water or chaser displacement. Even then, most of the time, part of the drillstring would be filled with non-Newtonian fluid.
  - b. *Power law fluid:* In rare occasions, power law equations are used to estimate the pressure drop in the drillstring. Some examples are cleaning agents, emulsions, etc.
  - c. *Bingham Plastic fluid:* this is the most commonly used equation in drilling applications as most of the muds and cement systems are indeed Bingham Plastic in nature.
3. **Annulus Pressure Drop:** The pressure drop in the annulus of the drillpipe and the drill collar mainly depend on the external diameters of the drill collar and the drillpipe, the bore hole size, the internal diameter of the casing and the drilling fluid flow rate. The cross-sectional fluid flow area in the annulus is larger than that of inside the drillstring. The flow in the annulus is usually assumed to be laminar due to

low fluid pressure and velocity. The frictional pressure loss in the annulus of the drillpipe and the drill collar can be calculated for both laminar and turbulent flow criteria depending on the type of drilling fluid used.

4. **Drill Bit Pressure Drop:** The pressure drop across the drill bit is the most important element in a hydraulics equation and is mainly due to the change of fluid velocities in the nozzles and the flow rate of the drilling fluid. The amount of hydraulic horsepower available at the drill bit is influenced by the size of nozzles used, the mud density and the flow rate. Typically no provision is made to include the influence of viscosity of the fluid used.
5. **Flow Exponent and Optimum Flow Rate:** The flow exponent ( $m$ ) between two points is deduced from the relationship between frictional pressure loss and flow rate. The flow exponent has a theoretical value of 1.75 (Bourgoyne, 1991). There are two basic criteria that are used in analyzing bit hydraulics for hole cleaning; either the drill bit hydraulics horsepower or the hydraulic jet impact force. They are:
  - a. *Drill Bit Hydraulic Horsepower Criterion:* Drill bit hydraulic horsepower criterion is based on the fact that cuttings are best removed from beneath the bit by delivering the most power to the bottom of the hole. The amount of pressure lost at the bit, or bit pressure drop, is essential in determining the hydraulic horsepower. This criterion states that the optimum hole cleaning is achieved if the hydraulic horsepower across the bit is maximized with respect to the flow rate (Azar and Samuel, 2007).
  - b. *Hydraulic (Jet) Impact Force Criterion:* Hydraulic (jet) impact force criterion is based on the fact that drill cuttings are best removed from beneath the bit when the force of the fluid leaving the jet nozzles and striking the bottom of the hole is very high. The maximum jet impact force criterion states that the bottom-hole cleaning is achieved by maximizing the jet impact force with respect to the flow rate. The jet impact force at the bottom of a wellbore can be derived from Newton's second law of motion (Azar and Samuel, 2007).
6. **Shallow Wellbore Formation:** When drilling a shallower portion of a wellbore formation, the frictional pressure loss is usually low and the flow rate requirement is large. Therefore,



the hydraulic jet impact force is limited only by the limited pump hydraulic horsepower (Azar and Samuel, 2007).

7. **Deep Wellbore Formation:** When drilling a deeper portion of the wellbore, the frictional pressure loss increases while the flow rate requirement decreases. Therefore, the hydraulic jet impact force will be limited by the limited maximum allowed pump pressure  $P_{max}$ .
8. **Drill Cutting Transport:** Drill cuttings in the annular space are subjected to numerous forces such as gravitational forces, buoyancy, drag inertia, friction and interparticle contact. The flow of cuttings in the annulus is dictated by these forces. Some of the factors that affect the capacity of drilling fluids to transport drilled cuttings through the annular space are cutting slip velocity, annular fluid velocity, and flow regime.
9. **Cutting Slip Velocity:** The cutting slip velocity is the rate at which drill cuttings fall. For the fluid to lift the drill cuttings to the surface, the fluid annular average velocity must be in excess of the cuttings average slip velocity. To maintain good hole cleaning, the velocity of the drilling fluid has to be greater than the slip velocity of the cuttings. The slip velocity depends on the difference in densities, viscosity of the fluid and the size of the cuttings.
10. **Annular Fluid Velocity:** The annular fluid velocity when drilling a vertical well has to be sufficiently high to avoid cuttings from settling and to transport these cuttings to the surface. The increasing radial component of a particle slip velocity pushes the particles towards the lower wall of the annulus, causing cuttings bed to form. Therefore, the annular velocity has to be sufficiently high to avoid bed formation.
11. **Flow Regime:** Flow regime describes the manner in which a drilling fluid behaves when flowing. The flow regime could be laminar or turbulent. Fluid flow may also be predominantly laminar at very low pump rates, but can become turbulent either at high pump rate or during pipe rotation. The characteristics of laminar flow that are useful to the drilling engineer are the low frictional pressures and minimum hole erosion. A high yield point for the mud tends to make the layers move at more uniform rates. Cuttings removal is often discussed as being more difficult with laminar flow. Turbulence occurs when increased velocities between the

layers create shear stresses exceeding the capacity of the mud to remain in laminar flow. Turbulence occurs commonly in the drillstring and occasionally around the drill collars. Reynolds number can be used to determine flow regime.

#### 4.1.5 Vibration

The problem of vibration leads to an array of drilling difficulties, which are discussed in detail in Chapters 2 and 6. In this section, we present the relevant aspect of vibration. The vibration is an unavoidable factor affecting the performance of the bits due to the drilling process of cutting rock either by (i) chipping (using drag bits), or (ii) crushing (using roller cone bits) action. Thus, many experimental and numerical studies were done on various drill bits materials in order to conduct the appropriate design of the drilling bits; these can be successfully used to drill very soft or ultra-hard formations and withstanding high temperatures and extended run time. It was found that the PDC bits can only cut relatively soft rock formations such as shales, soft, and unconsolidated sand stones, and carbonates. They cannot effectively drill hard formations such as granite, chert, pyrite, quartzite, and conglomerate. It was also found that the force response can be classified into four categories: (i) frictional effect, (ii) plowing effect, (iii) lateral interaction effect, and (iv) shearing effect. In addition, numerous research topics were achieved to improve the performance of the hammer drilling bits. Some of these studies involved strengthening of a bit material and profile optimization. Others involved wear prevention, force response predictions, and in-field process monitoring and dynamic process control.

## 4.2 Overall Recommendations

This section is designed to provide readers with an overall guidance for preventing and/or remedying hydraulics-related problems. As stated in previous sections, the hydraulics system is akin to the engine of a vehicle and keeping it in properly maintained status will ensure long-lasting smooth operations of the drilling system.

### 4.2.1 The Rig Infrastructure

The integrity of drilling equipment and its maintenance are major factors in minimizing drilling problems. Proper rig hydraulics (pump power) for

efficient bottom and annular hole cleaning, proper hoisting power for efficient tripping out, proper derrick design loads and drilling line tension load to allow safe overpull in case of a sticking problem, and well-control systems (ram preventers, annular preventers, internal preventers) that allow kick control under any kick situation are all necessary for reducing drilling problems. Proper monitoring and recording systems that monitor trend changes in all drilling parameters and can retrieve drilling data at a later date, proper tubular hardware specifically suited to accommodate all anticipated drilling conditions, and effective mud-handling and maintenance equipment that will ensure that the mud properties are designed for their intended functions are also necessary.

Rig manufacturers recommend periodically draining the hydraulic system and refilling with new fluid. Best practice is to remove all fluid from the system. Starting the system and heating the fluid first will decrease the time it takes to drain the system and allow impurities suspended in the fluid to be removed. If possible, bleeding the fluid at the lowest point in the system will also help. If deposits have accumulated and will not drain, one should flush the system with a light viscosity fluid that also contains a rust inhibitor to protect metal surfaces against rust formation after draining.

Leaks in the system can and should be corrected. Leakage can create fire and health hazards (clean up spills and leaks immediately), waste oil, increase machine downtime and decrease production rates. The minor cost of controlling leaks is negligible when compared to the long-term costs of leakage. Leaks are most likely to occur where a hose has been kinked or bent sharply. Severe bends can often occur at the end of the hose next to the fitting. Hydraulic components and fluids can become very hot and caution must be exercised. It is imperative not to attempt to detect leaks with bare hands. It is advisable that one avoids reaching the most trivial conclusion. For instance, when the start of a leak is noticed, it is tempting to look for tightening a connection or joint. However, the problem often has a deeper root. Notice that at the start of a leak, your first thought may be to tighten the connection. However, it's quite possible that another problem in the system needs to be addressed.

When valves require replacement, one must confirm that they are the correct type. Many types of valves may appear to be the same. However, they may operate in completely different ways due to different inner components. Fitting an incorrect valve can have serious consequences, including damaging the pump and other components.

No attempt to adjust any component should be made without first stopping the engine and placing all hydraulic moving parts in a locked position at rest. Hydraulic parts can be locked in position by oil pressure even when

the engine is not running and the removal of hydraulic hoses could cause parts to move due to gravitational down force. Therefore, all hydraulic pressure should be released before the commencement of any work on the rig. If a component requires repairment or replacement, one should confirm that the hydraulic hoses are suitable for the working pressure and that the hose fittings and connections are the correct type. A hydraulic hose failure can cause serious injury, so the use of damaged, frayed or deteriorated hoses must be avoided, and hoses should be replaced at the first signs of damage. High-pressure fittings should only be replaced in the workshop where appropriate tools are available.

#### 4.2.2 Problems Related to Stuckpipe

A complete discussion of this problem is presented in Chapter 6. In this section, we look into hydraulic system that affects the problem of stuckpipe. Often stuckpipe problems arise from non-optimal operation of the hydraulic system. Some of the indicators of differential-pressure-stuck pipe while drilling permeable zones or known depleted-pressure zones are an increase in torque and drag; an inability to reciprocate the drillstring and, in some cases, to rotate it; and uninterrupted drilling-fluid circulation. The occurrence of this problem can be prevented by the following precautions:

1. Maintain the lowest continuous fluid loss adhering to the project economic objectives.
2. Maintain the lowest level of drilled solids in the mud system, or, if economical, remove all drilled solids.
3. Use the lowest differential pressure with allowance for swab and surge pressures during tripping operations.
4. Select a mud system that will yield smooth mudcake (low coefficient of friction).
5. Maintain drillstring rotation at all times, if possible.

Note that the above guideline is applicable from the hydraulic considerations alone. Other factors might play a role, thus altering the optimal operating conditions described above. However, a global optimum must be sought that includes hydraulic components as a priority.

If sticking does occur, following measures should be attempted:

1. Mud-hydrostatic-pressure reduction in the annulus: Some of the methods used to reduce the hydrostatic pressure in the annulus include reducing mud weight by dilution, reducing

- mud weight by gasifying with nitrogen, and placing a packer in the hole above the stuck point.
2. Oil spotting around the stuck portion of the drillstring, and washing over the stuck pipe.

### 4.2.3 Mechanical Pipe Sticking

The causes of mechanical pipe sticking are inadequate removal of drilled cuttings from the annulus; borehole instabilities, such as hole caving, sloughing, or collapse; plastic shale or salt sections squeezing (creeping); and key seating. Excessive drilled-cuttings accumulation in the annular space caused by improper cleaning of the hole can cause mechanical pipe sticking, particularly in directional-well drilling.

The settling of a large amount of suspended cuttings to the bottom when the pump is shut down or the downward sliding of a stationary-formed cuttings bed on the low side of a directional well can pack a bottomhole assembly (BHA), causing pipe sticking. In directional-well drilling, a stationary cuttings bed may form on the low side of the borehole. If this condition exists while tripping out, it is very likely that pipe sticking will occur. This is why it is a common field practice to circulate bottom up several times with the drill bit off bottom to flush out any cuttings bed that may be present before making a trip. Increases in torque/drag and sometimes in circulating drillpipe pressure are indications of large accumulations of cuttings in the annulus and of potential pipe-sticking problems.

### 4.2.4 Borehole Instability

Chapter 9 addresses the borehole instability issues. It suffices to state here that special caution should be taken while drilling shale, salt, or similarly complex formations that exhibit either chemical or mechanical instability. Depending on mud composition and mud weight, shale can slough in or plastically flow inward, which causes mechanical pipe sticking. In all formation types, the use of a mud that is too low in weight can lead to the collapse of the hole, which can cause mechanical pipe sticking. Also, when drilling through salt that exhibits plastic behavior under overburden pressure, if mud weight is not high enough, the salt has the tendency of flowing inward, which causes mechanical pipe sticking. Indications of a potential pipe-sticking problem caused by borehole instability are a rise in circulating drillpipe pressure, an increase in torque, and, in some cases, no fluid return to surface.

There are clearly controllable factors that affect borehole stability. There are the ones that relate to the hydraulic system. These factors are discussed below.

#### 4.2.4.1 *Bottom Hole Pressure (mud density)*

In the absence of an efficient filter cake, such as in fractured formations, a rise in a bottom hole pressure may be detrimental to stability and can compromise other criteria, e.g., formation damage, differential sticking risk, mud properties, or hydraulics. Freeing mechanically stuck pipe can be undertaken in a number of ways, depending on what caused the sticking. For example, if cuttings accumulation or hole sloughing is the suspected cause, then rotating and reciprocating the drillstring and increasing flow rate without exceeding the maximum allowed equivalent circulating density (ECD) is a possible remedy for freeing the pipe. If hole narrowing as a result of plastic shale is the cause, then an increase in mud weight may free the pipe. If hole narrowing as a result of salt is the cause, then circulating fresh water can free the pipe. If the pipe is stuck in a key-seat area, the most likely successful solution is backing off below the key seat and going back into the hole with an opener to drill out the key section. This will lead to a fishing operation to retrieve the fish.

#### 4.2.4.2 *Well Inclination and Azimuth*

Inclination and azimuthal orientation of a well with respect to the principal in situ stresses can be an important factor affecting the risk of collapse and/or fracture breakdown occurring. This is particularly true for estimating the fracture breakdown pressure in tectonically stressed regions where there is strong stress anisotropy.

If the formation has a sufficiently low tensile strength or is pre-fractured, the imbalance between the pore pressures in the rock and the wellbore can literally pull loose rock off the wall. Surge pressures can also cause rapid pore pressure increases in the near-wellbore area sometimes causing an immediate loss in rock strength which may ultimately lead to collapse. Other pore pressure penetration-related phenomena may help to stabilize wellbores, e.g., filter cake efficiency in permeable formations, capillary threshold pressures for oil-based muds and transient pore pressure penetration effects (McLellan, 1994a).

#### 4.2.4.3 *Physical/chemical Fluid-rock Interaction:*

There are many physical/chemical fluid-rock interaction phenomena which modify the near-wellbore rock strength or stress. These include hydration, osmotic pressures, swelling, rock softening and strength changes, and dispersion. The significance of these effects depends on a complex interaction of many factors including the nature of the formation (mineralogy,

stiffness, strength, pore water composition, stress history, temperature), the presence of a filter cake or permeability barrier, the properties and chemical composition of the wellbore fluid, and the extent of any damage near the wellbore. Careful planning and compatibility tests under realistic conditions can help avert the problems of this nature.

#### 4.2.4.4 *Drillstring Vibrations*

Drillstring vibrations contribute to enlarging holes in some circumstances. Optimal bottomhole assembly (BHA) design with respect to the hole geometry, inclination, and formations to be drilled can sometimes eliminate this potential contribution to wellbore collapse. It is also likely that hole erosion may be caused due to a too high annular circulating velocity. This may be most significant in a yielded formation, a naturally fractured formation, or an unconsolidated or soft, dispersive sediment. The problem may be difficult to diagnose and fix in an inclined or horizontal well where high circulating rates are often desirable to ensure adequate hole cleaning.

#### 4.2.4.5 *Drilling Fluid Temperature*

Drilling fluid temperatures, and to some extent, bottomhole producing temperatures, can give rise to thermal contraction or expansion stresses which may be detrimental to wellbore stability. The reduced mud temperature causes a reduction in the near-wellbore stress concentration, thus preventing the stresses in the rock from reaching their limiting strength (McLellan, 1994a). By manipulating the flow rate, this problem can be alleviated.

### 4.2.5 **Lost Circulation**

Chapter 3 addresses the lost circulation issues. The complete prevention of lost circulation is impossible because some formations, such as inherently fractured, cavernous, or high-permeability zones, are not avoidable if the target zone is to be reached. However, limiting circulation loss is possible if certain precautions are taken, especially those related to induced fractures. These precautions include maintaining proper mud weight, minimizing annular-friction pressure losses during drilling and tripping in, adequate hole cleaning, avoiding restrictions in the annular space, setting casing to protect upper weaker formations within a transition zone, and updating formation pore pressure and fracture gradients for better accuracy with log and drilling data. If lost-circulation zones are anticipated, preventive measures should be taken by treating the mud with lost-circulation materials (LCMs).

When lost circulation occurs, sealing the zone is necessary unless the geological conditions allow blind drilling, which is unlikely in most cases. The common LCMs that generally are mixed with the mud to seal loss zones may be grouped as fibrous, flaked, granular, and a combination of fibrous, flaked, and granular materials. These materials are available in coarse, medium, and fine grades for an attempt to seal low-to-moderate lost-circulation zones. In the case of severe lost circulations, the use of various plugs to seal the zone becomes mandatory. It is important, however, to know the location of the lost-circulation zone before setting a plug. Various types of plugs used throughout the industry include bentonite/diesel-oil squeeze, cement/bentonite/diesel-oil squeeze, cement, and barite.

#### 4.2.6 Hole Deviation

Chapter 10 addresses the hole deviation issues. Hole deviation is the unintentional departure of the drill bit from a preselected borehole trajectory. Whether drilling a straight or curved-hole section, the tendency of the bit to walk away from the desired path can lead to higher drilling costs and lease-boundary legal problems. It is not exactly known what causes a drill bit to deviate from its intended path. It is, however, generally agreed that one or a combination of several of the following factors may be responsible for the deviation:

1. Heterogeneous nature of formation and dip angle.
2. Drillstring characteristics, specifically the BHA makeup.
3. Stabilizers (location, number, and clearances).
4. Applied weight on bit (WOB).
5. Hole-inclination angle from vertical.
6. Drill-bit type and its basic mechanical design.
7. Hydraulics at the bit.
8. Improper hole cleaning.

It is known that some resultant force acting on a drill bit causes hole deviation to occur. The mechanics of this resultant force is complex and is governed mainly by the mechanics of the BHA, rock/bit interaction, bit operating conditions, and, to some lesser extent, by the drilling-fluid hydraulics. The forces imparted to the drill bit because of the BHA are directly related to the makeup of the BHA (i.e., stiffness, stabilizers, and reamers). The BHA is a flexible, elastic structural member that can buckle under compressive loads. The buckled shape of a given designed BHA depends on the amount of applied WOB. The significance of the BHA



buckling is that it causes the axis of the drill bit to misalign with the axis of the intended hole path, thus causing the deviation. Pipe stiffness and length and the number of stabilizers (their location and clearances from the wall of the wellbore) are two major parameters that govern BHA buckling behavior. Actions that can minimize the buckling tendency of the BHA include reducing WOB and using stabilizers with outside diameters that are almost in gauge with the wall of the borehole.

The contribution of the rock/bit interaction to bit deviating forces is governed by rock properties (cohesive strength, bedding or dip angle, internal friction angle); drill-bit design features (tooth angle, bit size, bit type, bit offset in case of roller-cone bits, teeth location and number, bit profile, bit hydraulic features); and drilling parameters (tooth penetration into the rock and its cutting mechanism). The mechanics of rock/bit interaction is a very complex subject and is the least understood in regard to hole-deviation problems. Fortunately, the advent of downhole measurement-while-drilling tools that allow monitoring the advance of the drill bit along the desired path makes our lack of understanding of the mechanics of hole deviation more acceptable.

### 4.3 Summary

Drilling hydraulics is one of the most important issues in drilling engineering. This chapter covers almost all aspects of hydraulics. The different types of fluids, models, and flow regimes are discussed elaborately. The pressure loss calculation shows the losses at different parts of the circulating system. The current and future trends of the hydraulic system are also discussed in the last sections of the chapter.

### References

- Aadnoy, B.S. and Kaarstad, E. (2010). Elliptical Geometry Model for Sand Production during Depletion. SPE132689-MS, Presented at IADC/SPE Asia Pacific Drilling Technology Conference and Exhibition, 1-3 November, Ho Chi Minh City, Vietnam
- Akhtarmanesh, S., M.J.A. Shahrabi, M.J.A. A. Atashnezhad, A., 2013, Improvement of wellbore stability in shale using nanoparticles, *J. Pet. Sci. Eng.* 112: 290–295.
- Albdiry, M.T., Almensory, M.F., 2016, Failure analysis of drillstring in petroleum industry: A review, *Engineering Failure Analysis* 65 (2016) 74–85.
- Awal, M.R., Khan, M.S., Mohiuddin, M.A., Abdurraheem, A. and Azeemuddin, M. (2001). A New Approach to Borehole Trajectory Optimization for Increased

- Hole Stability, paper SPE 68092 presented at the 2001 SPE Middle East Oil Show, Bahrain, 17-20 March 2001.
- Azar, J. J., & Samuel, R. (2007). *Drilling Engineering*. Texas: Pennwell Corporation.
- Bourgoynne, A. T. and Chenevert, M. E., 1991, *Applied Drilling Engineering*. Texas: SPE.
- Bradley, W. (1978). Bore Hole Failure Near Salt Domes, paper SPE 7503 presented at the 53th Annual Technical conference and Exhibition of the SPE of AIME, Houston, Texas, 1-3 October 1978.
- Cheng, L., Tianhuai, D., W. Peng, W., 2011, An experimental rig for near-bit force measurement and drillstring acoustic transmission of BHA, *Measurement*, 44: 642–652.
- Kristiansen, T.G. (2004). Drilling Wellbore Stability in the Compacting and Subsiding Valhall Field, paper IADC/SPE 87221 presented at the IADC/SPE Drilling Conference, Dallas, Texas, 2-4 March 2004.
- Martins, A.L., Santana, M.L., Goncalves, C.J.C., Gaspari, E., Campos, W., and Perez, J.C.L.V. (1999). Evaluating the Transport of Solids Generated by Shale Instabilities in ERW Drilling Part II: Case Studies, paper SPE 56560 presented at the 1999 SPE annual Technical Conference and Exhibition, Houston, Texas, 3-6 October 1999.
- Ogolo, N.A., Onyekanwu, M.A., and Ajienska, J.A. (2011). Application of Nanotechnology in the oil and gas industry (Port Harcourt: Institute of Petroleum Studies, 2011, pp.15 – 16.
- Osisanya, O. (2012). Practical Approach to Solving wellbore instability problems, SPE Distinguished Lecture series, Port Harcourt, 2012.
- Pasic, B., Gaurina, N. and Mantanovic, D. (2007). Wellbore instability: Causes and Consequences, *Rud-geol, Zb*, vol. 19, 2007, pp. 87 – 98.
- Rabia, H. *Well Engineering and Construction*, pp. 457 – 458.
- Ranjbar, K. and Sababi, M., 2012, Failure assessment of the hard chrome coated rotors in the downhole drilling motors, *Eng. Fail. Anal.* 20:147–155.
- Tan, C.P., Yaakub, M.A., Chen, X., Willoughby, D.R., Choi, S.K. and Wu, B. (2004). Wellbore Stability of Extended Reach Wells in an Oil Field in Sarawak Basin. SPE 88609, presented at SPE Asia Pacific Oil and Gas Conference and Exhibition, 18-20 October, Perth, Australia.
- Wami, E.N. (2012). Drilling Fluid Technology. Lecture notes, Port Harcourt, Rivers State University of Science and Technology.
- Wang, R.H., *et al.*, 2011, Over 130 drillstring failure cases have been recorded among 37 wells drilled in northeast Sichuan (China), *Engineering Failure Analysis* 18: 1233–1241.
- Yongjiang Luo, J.P.Y. et al, 2016, Development of a specially designed drill bit for down-the-hole air hammer to reduce dust production in the drilling process, *J. Clean. Prod.* 112 (2016) 1040–1048.
- Zeynali, M.E., 2012, Mechanical and physico-chemical aspects of wellbore stability during drilling operations, *J. Pet. Sci. Eng.*, 82-83: 120–124.
- Zhang, J., 2013, Borehole stability analysis accounting for anisotropies in drilling to weak bedding planes, *Int. J. Rock Mech. Min. Sci.* 60: 160–170.

# 5

## Well Control and BOP Problems

### 5.0 Introduction

A well control and monitoring system is an integral part of the drilling operations. Well control means an assurance of formation fluid (oil, gas or water) that does not flow in an uncontrolled way from the formations being drilled, into the borehole and eventually to the surface. It prevents the uncontrolled flow of formation fluids ('kick') from the wellbore. Hence, a kick can be defined as an unexpected entry of formation fluid(s) into the wellbore, causing a rise of mud-level in the mud pit. The onset of this process can lead to blowout – the ultimate failure of a drilling operation in terms of safety and environmental impact. Therefore, controlling of the well is an important issue in any drilling activity.

The well control system can be defined as the technology usages to control the fluid invasion and to maintain a balance between borehole pressure (i.e., pressure exerted by the mud column in the wellbore) and formation pressure (i.e., pressure in the pore space of the formation) for preventing or directing the flow of formation fluids into the wellbore. The control system must have the options: (i) to detect a kick, (ii) to close the well at surface,

(iii) to remove formation fluid, and iv) to make the well safe. This technology includes the approximation of formation fluid pressures, the strength of the subsurface formations and the use of casing and mud density to offset those pressures in an expected fashion. It also includes the operational procedures to safely stop a well from flowing fluid as an influx of formation fluid. The well-control procedure starts with installing large valves at the top of the well to enable well-site personnel to close the well if necessary.

Properly trained personnel are essential for well control activities. Well control consists of two basic components: (i) an active component consisting of drilling fluid pressure monitoring activities, and (ii) a passive component consisting of the Blowout Preventers (BOPs). The first line of defense in well control is to have sufficient drilling fluid pressure in the well hole. During drilling, underground fluids such as gas, water, or oil under pressure (i.e., the formation pressure) opposes the drilling fluid pressure (i.e., mud pressure). If the formation pressure is greater than the mud pressure, there is the possibility to have a kick and ultimately a blowout. This chapter covers the well control system, and problems related to drilling.

## 5.1 Well Control System

The control of the formation pressure is normally referred to as keeping the pressures in the well under control or simply well control. When pressure control over the well is lost, immediate action must be taken to avoid severe consequences of the blowout. The consequences may include: (i) loss of human life, (ii) loss of rig and equipment, (iii) loss of reservoir fluids, (iv) damage to the environment, (v) loss of capital investment, and (vi) huge cost involvement to bring the well back under control. Therefore, it is important to understand the principles of well control, procedures and equipment used to prevent blowouts. The details can be found in Hossain and Al-Majed (2015).

An optimum drilling operation requires close control over several parameters. A modern rig should have devices which will show and at the same time record the important parameters related to the drilling operation. Some of the most important parameters that are related to drilling operations, and well control and monitoring system are: (i) well depth, (ii) weight on bit (WOB), (iii) hook load, (iv) rotary speed, (v) rotary torque, (vi) mud flow rate, (vii) pump rate, (viii) flow return, (ix) pump pressure, (x) pit level, (xi) rate of penetration (ROP), (xii) fluid properties (e.g., density, temperature, viscosity, salinity, gas content, solids content etc.), (xiii) hazardous gas content of air. In addition, some parameters such

as mud properties cannot be determined automatically. These parameters are measured, recorded, and controlled constantly as well through physical experiments. Therefore, it is mandatory that rig personnel (i.e., rig supervisor, driller, crews, drilling and mud engineer) keep track of the operation development always to make necessary adjustments and to quickly detect and correct drilling problems. The rig crews must be alert at all the times to recognize the signs of a kick and take immediate action to bring the well back under control. The kick occurs due to the pressure imbalance (i.e., the pressure inside the wellbore ( $P_w$ ) is lower than the formation pore pressure ( $P_f$ ) in a permeable formation). The imbalance might happen if the mud density is too low, or fluid level is too low due to the mud-loss, and lost circulation (e.g., swabbing i.e., cleaning on trips; and circulation stopped i.e., ECD is too low). As a result, severity of kick depends on several factors: (i) type of formation, (ii) formation pressure, and (iii) the nature of influx. The higher the permeability and porosity of the formation, the greater the potential for a severe kick. The greater the negative pressure differential (i.e., formation pressure to wellbore pressure), the easier it is for the formation fluids to enter the wellbore, exclusively if this is coupled with high permeability and porosity. Finally, gas will flow into the wellbore much faster than oil or water and therefore, the obvious result is blowout if a kick is not controlled.

Well control operations are urgently needed when formation fluids start to flow into the well and displace the mud. Figure 5.1 shows the hydraulic flow paths during well-control operations. Formation fluids that have

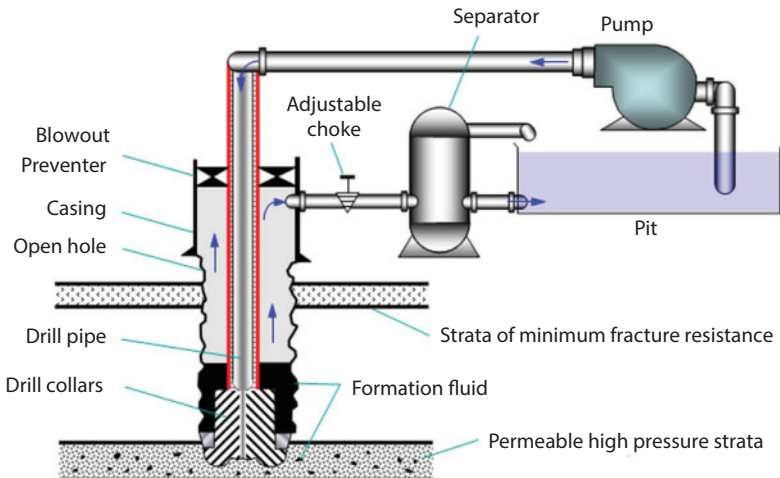

**Figure 5.1** Schematic of well control operations (Hossain and Al-Majed, 2015).

entered into the wellbore generally must be removed by circulating the well through an adjustable chock at the surface (Figure 5.1). The bottomhole pressure of the well always must remain above the pore pressure of the formation to prevent additional influx of the formation fluid. A detailed study on well control and monitoring program is presented by Hossain and Al-Majed (2015).

## **5.2 Problems with Well Control and BOP and their Solutions**

If the well is not controlled properly during drilling operations, there is always a potential of encountering well control problems. Research shows that the majority of these well control problems stem from some human errors. Most of these errors can be avoided easily while others are inevitable. As we stated earlier, the consequences of loss of well control are severe. Therefore, efforts should be made to stop errors which are the main causes of these incidents. These human errors are listed as: (i) lack of knowledge and skills of rig personnel, (ii) improper work practices, (iii) lack of understanding of oil well control training, (iv) lack of application of policies, procedures, and standards, and (v) inadequate risk engineering and management. The most common well control problems while drilling are listed as: (i) kicks, (ii) blowout, (iii) oil well fire, and (iv) formation fluid. In this, oil fire of concern is the outcome of an uncontrolled well, whereas formation fluid is often the source of the problem. As such, we will confine our discussion to the topics of kicks and blowout.

### **5.2.1 Kicks**

A kick is defined as an uncontrolled influx of formation fluid into the wellbore (Figure 5.2). If the formation pressure is higher than the mud hydrostatic pressure acting on the borehole or rock face, a kick may occur (Figure 5.3). When this type of situation arises, there is a great chance of formation fluids being forced into the wellbore. This unexpected formation fluid flow is called a kick. Kicks occur as a result of formation pressure being greater than mud hydrostatic pressure, which causes fluids to flow from the formation into the wellbore (Figure 5.2). In almost all drilling operations, the operator attempts to maintain a hydrostatic pressure greater than formation pressure and, thus, prevent kicks; however, on occasion the formation will exceed the mud pressure and a kick will occur. If this unwanted flow is effectively controlled, there would not be any kick

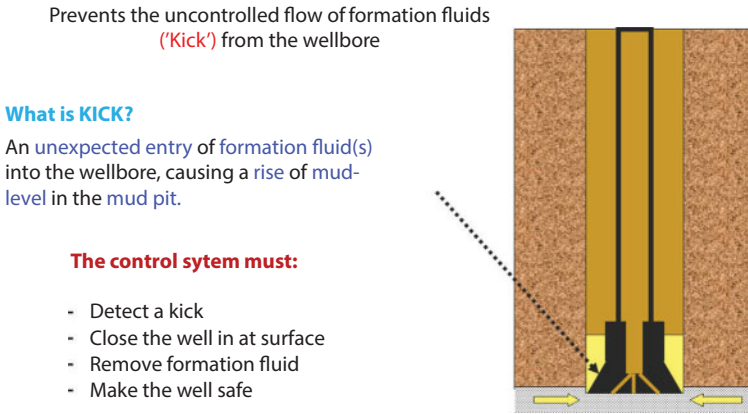

Figure 5.2 Schematic of formation fluid influx.

**Why does a kick occur?**

**Pressure imbalance:**

The pressure inside the wellbore ( $P_w$ ) is lower than the formation pore pressure ( $P_f$  in a permeable formation).

*Why pressure imbalance*

*Reasons:*

- Mud density is too low
- Fluid level is too low due to Mud-loss during trips

or

*Lost circulation.*

- swabbing (i.e. cleaning) on trips
- Circulation stopped - ECD too low

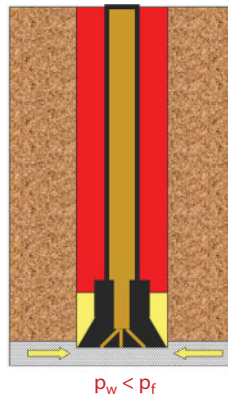

Figure 5.3 Mechanism and reasons of kick.

(i.e., kick has been killed). In contrast, if the flow is not controlled properly on time, the severity may result in “blowout.” Kicks may happen because of the following reasons: (i) insufficient mud weight, (ii) improper hole fill-up during trips, (iii) swabbing, (iv) cut mud, (v) lost circulation, (vi) drilling into abnormal pressure, (vii) annular flow after cement job, (viii) loss of control during drill stem test (DST), (ix) drilling into adjacent wells, and (x) drilling through (i.e., shallow) gas zones at excessive rates.

Kick detection is mostly achieved by means of measurement and observation at the surface of the drilling fluid and drilling equipment. If a kick

is not controlled, it will continue to grow in the wellbore until there is a blowout. Kick control is dependent upon time-to-detection. Kick detection in a subsea well is more problematic because the subsea well contains a large volume of drilling fluid between the wellbore and the surface kick detection – the volume of mud in the riser – which can mask a kick or delay detection. This additional volume in the riser may be up to twice as much as the volume in the wellbore. In any case, control of a kick in a subsea well can be improved if detection of the kick can be made sooner.

Early kick detection (EKD) is one of the most important focus areas for preventing loss of well control (LWC) events in the drilling operations. Bureau of safety and environmental enforcement (BSEE) defines the LWC as: (i) uncontrolled flow of formation or other fluids. The flow may be to an exposed formation (an underground blowout) or at the surface (a surface blowout, (ii) flow through a diverter, and (iii) uncontrolled flow resulting from a failure of surface equipment or procedures. If kicks are accurately detected and recognized earlier, they can easily be managed and thus stress levels on equipment and personnel can be reduced. This approach can lower down the risk of adverse consequences which ultimately helps in resuming safe and quick drilling operations. Two recent observations related to the importance of EKD are: (i) a study of the BSEE's incident database shows that approximately 50% of drilling related LWC events could have been prevented or improved with early kick detection, and (ii) not properly reading or interpreting kick indicators is a key factor. These results imply that an EKD system providing direct and unambiguous indications of a kick can alert the crew significantly earlier.

The severity factors of kicks are indicated by the Shut-in drillpipe pressure (SIDP) and the gain in pit volume. These factors are: (i) permeability (i.e., permeability of rock is the ability of the rock to allow fluid to move through it, (ii) porosity (i.e., porosity measures the amount of space in the rock containing fluids. So, for the above factor sandstone can be considered to have more of a kick than shale because sandstone has greater permeability and greater porosity), (iii) pressure differential (i.e., pressure differential is the difference between the formation fluid pressure and the mud hydrostatic pressure, (iv) amount of formation exposed to the wellbore, and (v) rate and the type of fluid flow into the wellbore before the well is shut-in (i.e., oil, gas, or water).

Controlling kick is the most important issue to safeguard the well and resume the drilling operations. The first step in controlling a kick is to detect it either: (i) very shortly after it occurs, or (ii) before a large volume of formation fluid has flowed into the wellbore. If the hole being drilled through formations has an increasing pressure gradient and in this case,



the operator/driller should be alert for a pending kick. Schubert *et al.* (1998) demonstrated the operational procedures to close in the well. The kick control action items need to start as soon as the monitors/sensors indicate a kick. The kick is controlled by: (i) closing in the well, (ii) lighter kick fluids must be circulated out of the hole and replaced the heavier mud, and (iii) the driller immediately shuts off the rotary and starts to pick up the pipe, in case of drilling break.

### 5.2.1.1 *Warning Signals of Kicks*

A blowout does not usually occur suddenly. While drilling, the crew must be watchful and wary of the signs that may lead to blowout. They should know the warning signs at the surface and be able to understand the influx at the bottom of the bore hole. An alert crew can see the warning signs and if they are interpreted correctly, the well can be saved by immediate corrective actions. Even though these signs may not be necessarily always positively identified as a kick, they provide a warning and should be monitored carefully. Sometimes the driller observes several indicators at the surface which might be due to events other than an influx. As a result, the signs are not always the final ones. For example, if the drill bit enters in an overpressured zone of a formation, the rate of penetration will increase. It might have happened due to the new formation encountered by the bit. On the other hand, some indicators need to be monitored continuously to restrict having kick. Normally there are two types of indicators: (i) primary indicators, and (ii) secondary indicators.

#### **Primary Indicators**

While drilling, there are some indicators that are more obvious than others and are therefore called primary indicators. The following are the primary indicators: (i) flow rate increase, (ii) pit volume increase, (iii) flowing well with pump shut off, and (iv) improper hole fill-up during trips.

- i. **Flow rate increase:** while the mud pumps are circulating at a constant rate there should be a steady flow rate of mud returns to the mud tank or pit. If this flow rate increases without changing the pump speed, this is a sign that formation fluids are entering the wellbore and helping to move the contents of the annulus to the surface. Therefore, it very important to monitor flow rate into and out of the well continuously using a differential flow meter. The meter measures the differential rate at which fluid is being pumped into the well and the rate at which it returns from the annulus along

the flow line. The practice gives the indication of flow rate increase to the drilling crew.

- ii. **Pit volume increase:** if the mud flow rate into and out of the well is constant, the volume of fluid in the mud pit should remain constant. A rise in the level of mud in the active pits is a sign that some mud has been displaced from the annulus by an influx of formation fluids. The level of the mud in the mud pits is therefore monitored continuously. The volume of this influx is equal to the pit gain and should be noted for use in later calculations.
- iii. **Flowing well with pump shut off:** when the rig pumps are not in an operating condition, there should be no fluid returns from the well. If the pumps are in shut down condition and the well continues to flow, then the fluid is being pushed out of the annulus by some other forces. In such case, it is assumed that the formation pressure is higher than the hydrostatic pressure due to the column of mud. This higher pressure results in an influx to the wellbore which ultimately fallouts to have a kick. There are two exceptions to this explanation: i) the thermal expansion of mud in the borehole and annulus which results in a small amount of flow when the pumps are shut off, ii) U-tubing effect when mud in drillstring is heavier than mud in annulus. A flow check is often carried out to confirm whether the well is kicking or not. The procedure is as follows: i) pick up kelly until tool joint clears rotary table, ii) shut down pumps, iii) sets slips, iv) observe flow line, check for flow from annulus, v) if well is flowing, close BOP. If not flowing, resume drilling.
- iv. **Improper hole fill-up during trips:** the hole should be required to be filled up with mud when pipe is tripped out. If the hole is not being filled and does not take the calculated drillpipe volume, the empty space will be replaced by formation fluids.

### Secondary Indicators

While drilling, there are some indicators that are not conclusive and may be due to some other reasons. The followings are the secondary indicators: (i) changes in pump pressure, (ii) drilling break, (iii) gas, oil, or water-cut mud, and (iv) reduction in drillpipe weight.

- i. **Changes in pump pressure:** an entry of formation fluids may cause the mud to flocculate and result in a slight increase in pump pressure. As flow continues the lower

density of the influx will cause a gradual drop in pump pressure. As the fluid in the annulus becomes lighter the mud in the drillpipe will tend to fall and the pump speed (stokes/min) will increase. Notice, however, that these effects can be caused by other drilling problems (i.e., washout in drillstring, or twist-off).

- ii. **Drilling break:** a drilling break is an abrupt increase in the rate of penetration. It should be treated with caution. If drilling parameters have not been changed, the increased penetration rate may be attributed to: a) change from shale to sand (i.e., more porous and permeable and so having a greater kick potential), or b) reduced overbalance (i.e., increase in pore pressure). The drilling break may indicate that a higher-pressure formation has been entered and therefore the chip hold down effect has been reduced and/or that a higher porosity formation (i.e., due to under-compaction and therefore indicative of high pressure) has been entered. However, an increase in drilling rate may also be simply due to a change from one formation type to another. Experience has shown that drilling breaks are often associated with overpressured zones. It is recommended that a flow check is carried out after a drilling break.
- iii. **Gas, oil, or water cut mud:** gas cut mud can be defined as the mud where an entrance of gas happens from formations while drilled. It is not possible to prevent any gas entrance to the mud column. Gas cut mud may be considered as an early warning sign. The mud should be continuously monitored. Any significant rise above background level should be reported. Gas cutting may occur due to: a) drilling in a gas bearing formation with the correct mud weight, b) swabbing when making a connection or during trips, and c) influx due to negative pressure differential. The detection of gas in the mud does not necessarily mean the weight should be increased. The cause of the gas cutting should be investigated before action is taken.
- iv. **Reduction in drillpipe weight:** the reduction in drillstring weight happens when a substantial influx occurs from a zone of high productivity. However, the other indicators may be displayed prior to or along with a reduction in drillpipe weight.

The operational procedure to deal with a kick while drilling is depicted in Figure 5.4. During the operation, it is not essential to close valves inside

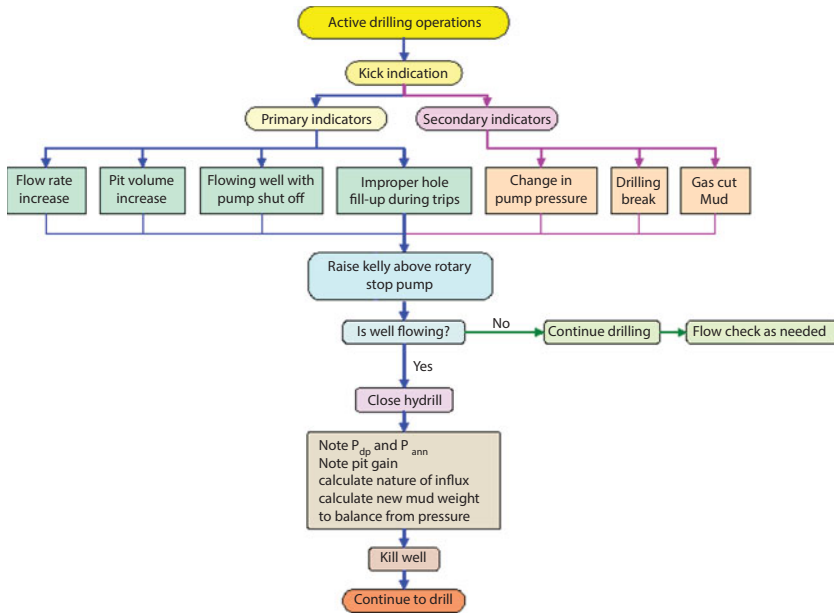

**Figure 5.4** Operational procedure flowing detection of a kick (Hossain and Al-Majed, 2015).

the drillpipe since the drillpipe is connected to the mud pumps. This allows controlling the pressure to the drillpipe. Generally, it is required to close the uppermost annular preventer (i.e., hydrill). However, the lower pipe rams can also be used as a backup if required. The surface and annulus pressure should be monitored carefully. The pressures can also be used to identify the nature of the influx and calculate the mud weight required to kill the well (Figure 5.4).

### 5.2.1.2 Control of Influx and Kill Mud

Once there is an influx of the formation fluid (i.e., kick) at the borehole, it is necessary to control the well effectively. Otherwise, the well would be beyond control. Therefore, kill mud calculations are needed to bring back the well under primary control. The following subsections describe how a well can be controlled by the kill mud.

#### Analysis of Shut-in-Pressure

When the formation fluid is already in wellbore and as a result, the well is in shut-in condition, the pressures at the drillpipe and the annulus can be used to determine i) the formation pore pressure, ii) the mud weight

required to kill the well, and iii) the type of influx. Due to the shut-in condition, the pressure at the top of the drillstring will increase until the sum of drillpipe pressure and the hydrostatic pressure due to the fluids in the drillpipe are equal to the pressure in the formation. For the same reason, the pressure in the annulus would continue to increase until the sum of annulus pressure and the hydrostatic pressure due to the fluids in the annulus are equal to the pressure in the formation. It is noted that the drillpipe and annulus pressure will be different because of the different fluids content while shut-in. When the influx happens and the well is shut-in, the drillpipe will contain mud. However, the annulus will now contain both mud and the invaded fluid (i.e., oil, gas, or water). Hence the hydrostatic pressure of the muds in the drillstring and the annulus will be different. It is assumed that no influx will flow through drillstring. If the system is in equilibrium, the drillpipe shut-in pressure can be interpreted as the amount by which bottom hole pressure exceeds the hydrostatic mud pressure. Mathematically the expression can be written as:

$$P_{sidp} + G_m H_{vc} = P_{bh} \quad (5.1)$$

where,

- $P_{sidp}$  = shut-in drillpipe pressure, psi
- $G_m$  = mud pressure gradient, psi/ft
- $H_{vc}$  = total vertical height of the mud column, ft
- $P_{bh}$  = bottom hole (i.e., formation) pressure, psi

In terms of mud weight, formation pressure can be calculated as:

$$P_{bh} = P_{sidp} + 0.052 \rho_{om} H_{vc} \quad (5.2)$$

where,

- $\rho_{om}$  = original mud weight, ppg

Since the mud weight in the drillpipe will be known throughout the well control procedure,  $P_{sidp}$  gives an indication of bottom hole pressure (i.e., the drillpipe pressure gauge acts as a bottom hole pressure gauge). Throughout the well control procedure, the further influx of formation fluids must be prevented. In order to do this,  $(P_{sidp} + G_m H_{vc})$  must be kept equal or slightly above  $P_{bh}$ . This is an important concept of well control on which everything else is based. Sometime this technique is referred to as the constant bottom hole pressure killing methods due to this reason.

Now, if we consider the annulus side, the bottom hole pressure can be calculated as equal to the surface annulus pressure plus the combined hydrostatic pressure of the mud and influx. Mathematically the expression can be written as:

$$P_{siann} + G_i H_i + G_m H_m = P_{bh} \quad (5.3)$$

where,

- $P_{siann}$  = shut-in annulus pressure, psi
- $G_i$  = influx pressure gradient, psi/ft
- $H_i$  = vertical height of the influx or kick, ft
- $H_m$  = vertical height of mud in the annulus after influx, ft =  $H_{vc} - H_i$

$H_i$  can be calculated from the displaced volume of mud measured at surface (i.e. the pit gain) and the cross-sectional area of the annulus, i.e.:

$$H_i = \frac{V_{pit}}{A_{ann}} \quad (5.4)$$

where,

- $V_{pit}$  = pit gain volume, bbls
- $A_{ann}$  = cross-sectional area of the annulus, bbls/ft

Initial circulating pressure is calculated as:

$$P_{ic} = P_{sidp} + P_p + P_{ok} \quad (5.5)$$

where,

- $P_{ic}$  = initial circulating pressure, psi
- $P_p$  = slow circulating pump pressure, psi
- $P_{ok}$  = overkill pressure, psi

Final circulating pressure is calculated as:

$$P_{fc} = P_p \left( \frac{\rho_{km}}{\rho_{om}} \right) \quad (5.6)$$

where,

- $P_{fc}$  = final circulating pressure, psi
- $\rho_{km}$  = kill mud weight, ppg

**Example 5.1:** A 8½" diameter hole is drilled up to 7500 ft with a density of 12.5 ppg. If the formation pore pressure at this point is 4500 psi. Calculate i) mud pressure overbalance above the pore pressure, ii) if the mud density is 10.5 ppg, what would be the overbalance, and iii) if the fluid level in the annulus is dropped to 250 ft due to inadequate hole fill up during tripping, what would be the effect on bottom hole pressure?

**Solution:**

**Given data:**

- $H_{vc}$  = total vertical height of the mud column = 7500 ft
- $d_h$  = hole diameter = 8½"
- $r_{om1}$  = original mud weight 1 = 12.5 ppg
- $P_f$  = formation pore pressure = 4500 psi
- $r_{om2}$  = original mud weight 2 = 10.5 ppg
- $H_{ann}$  = vertical height of the mud column in the annulus = 250 ft

**Required data:**

- i.  $P_{ob1}$  = mud pressure overbalance at 7500 ft
- ii.  $P_{ob2}$  = mud pressure overbalance at 7500 ft if mud density is 10.5 ppg
- iii. Effect on bottom hole pressure?

The overbalance at a depth of 7,500 ft can be calculated by Eq. (5.34a) which can be modified for overbalance as (Hossain and Al-Majed, 2015):

$$\begin{aligned} P_{ob1} &= 0.052 \rho_{om1} H_{vc} - P_f \\ &= 0.052 \times (12.5 \text{ ppg}) \times (7500 \text{ ft}) - 4500 \text{ psi} = 375 \text{ psi} \end{aligned}$$

The overbalance at a depth of 7500 ft if mud density is 10.5 ppg as:

$$\begin{aligned} P_{ob2} &= 0.052 \rho_{om2} H_{vc} - P_f \\ &= 0.052 \times (10.5 \text{ ppg}) \times (7500 \text{ ft}) - 4500 \text{ psi} = -405 \text{ psi} \end{aligned}$$

If the mud density is decreased, the negative sign implies that the well would be underbalanced by 405 psi with the consequent risk of an influx.

If the fluid level in the annulus is dropped by 250 ft, the effect would be to reduce the bottom hole pressure by:

$$P_{bhp} = 0.052 \times (12.5 \text{ ppg}) \times (250 \text{ ft}) = 162.5 \text{ psi}$$

This result indicates that there would still be a net overbalance of **212.5** (i.e. 375–162.5) **psi**.

### Type of Influx and Gradient Calculation

If we combine Eqs. (5.1) and (5.3), the influx gradient can be calculated as:

$$G_i = G_m - \frac{P_{siann} - P_{sidp}}{H_i} \quad (5.7)$$

It is noted that the above expression is given in this form because  $P_{ann} > P_{dp}$ , due to the lighter fluid being in the annulus. The type of fluid can be identified from the gradient calculated utilizing Eq. (5.7). Different references report different ranges of data for identifying the fluid types. However, the following are as a guide.

A gas kick is recognized:  $0.075 < G_i < 0.25$  psi/ft

An oil and gas mixture kick:  $0.25 < G_i < 0.3$  psi/ft

An oil and condensate mixture kick:  $0.3 < G_i < 0.4$  psi/ft

A water kick:  $0.4 < G_i$  psi/ft

For example, if  $G_i$  is found to be above 0.25, this may indicate a mixture of gas and oil. If the nature of the influx is not known, it is usually assumed to be gas, since this is the most severe type of kick.

### Kill Mud Weight Calculation

The mud weight required to kill the influx and would provide the overbalance while drilling ahead can be calculated from Eq. (5.1) as:

$$P_{bh} = P_{sidp} + G_m H_{vc} \quad (5.8)$$

To bring back the well under primary control, the new mud weight must be adequate to balance or be slightly greater than the bottom hole pressure. One more thing should be taken care during the design of mud weight. We should keep in mind that the kill mud weight would not be exceeding the formation fracture gradient. Otherwise, there would be mud loss in the fracture. If an overbalance is used the equation becomes:

$$G_k H_{vc} = P_{bh} + P_{ob} \quad (5.9)$$

where,

$G_k$  = kill mud pressure gradient, psi/ft

$P_{ob}$  = overbalance pressure, psi



Substituting Eq. (5.8) into Eq. (5.9), the final form of the above equation can be written as:

$$G_k = G_m + \frac{P_{sidp} + P_{ob}}{H_{vc}} \quad (5.10)$$

It is noted that the pit gain volume ( $V$ ) and the casing pressure (i.e.  $P_{siann}$ ) do not appear in Eq. (5.10) which indicate that both parameters do not have any role over kill mud design and calculations.

Formation pressure can be calculated in terms of mud weight as

$$P_{bh} = P_{sidp} + 0.052\rho_{om}H_{vc} \quad (5.11)$$

The kill mud weight can be calculated in terms of mud weight as

$$\rho_{km} = \frac{P_{sidp}}{0.052H_{vc}} + \rho_{om} \quad (5.12)$$

If we consider overkill mud as a safety margin, Eq. (5.12) can be written as:

$$\rho_{km} = \rho_{om} + \frac{P_{sidp}}{0.052H_{vc}} + \rho_{ok} \quad (5.13)$$

where,

$\rho_{ok}$  = overkill mud weight for safety margin, ppg

The kill mud gradient can be calculated in terms of mud weight as

$$G_k = 0.052\rho_{om} + \frac{P_{sidp}}{H_{vc}} \quad (5.14)$$

**Example 5.2:** while drilling ahead at a target of 8,500 ft, the hole size was 7 in. The drilling crew noticed that there was a pit gain of 10 bbls. The well is shut-in and the drillpipe and annulus pressures were recorded as 650 psi, and 800 psi respectively. The bottomhole assembly consists of 650 ft of 4¾" OD collars and 3½" drillpipe. The mud weight is 10.2 ppg. Assume a mud

pressure gradient. Identify the influx and calculate the new mud weight, including an overbalance of 250 psi.

**Solution:**

**Given data:**

- $H_{vc}$  = total vertical height of the mud column = 8500 ft  
 $d_h$  = hole diameter = 7 in  
 $V_{pit}$  = pit gain volume = 10 bbls  
 $P_{dp}$  = shut-in drillpipe pressure = 650 psi  
 $P_{ann}$  = shut-in annulus pressure = 800 psi  
 $H_{BHA}$  = bottomhole assembly length = 650 ft  
 $d_c$  = collar outer diameter =  $4\frac{3}{4}'' = 4.75^2$   
 $d_{dp}$  = drillpipe diameter =  $3\frac{1}{2}'' = 3.5^2$   
 $r_m$  = mud weight = 10.2 ppg  
 $P_{ob}$  = overbalance pressure = 250 psi

**Required data:**

- Type of influx
- $\rho_m$  = new mud weight in ppg

**Nature of influx:**

The vertical height of the influx can be calculated using Eq. (5.4) as

$$\begin{aligned}
 H_i &= \frac{V_{pit}}{A_{ann}} = \frac{10 \text{ bbls}}{\pi(d_h^2 - d_c^2)/4} = \frac{(10 \text{ bbls}) \times \left( \frac{\text{ft}^3}{0.178 \text{ bbls}} \right)}{\left\{ \frac{\pi(7^2 - 4.75^2)}{4} \text{ in}^2 \right\} \times \frac{\text{ft}^2}{144 \text{ in}^2}} \\
 &= 389.6 \text{ ft}
 \end{aligned}$$

(Here,  $H_i$  is less than bottomhole assembly length, 650 ft)

Assuming a mud pressure gradient of 0.53 psi/ft, the type of influx can be calculated using Eq. (5.7) as:

$$G_i = G_m - \frac{P_{siann} - P_{sidp}}{H_i} = 0.53 - \frac{800 - 650}{389.6} = 0.145 \text{ psi/ft}$$

If the influx pressure gradient is within the range 0.075–0.25 psi/ft, the type of influx is probably **gas**.

**New mud weight:**

The new mud weight or kill mud weight can be calculated using Eq. (5.10) as:

$$\begin{aligned} G_k &= G_m + \frac{P_{dp} + P_{ob}}{H_{vc}} = (0.53 \text{ psi/ft}) + \frac{(650 \text{ psi}) + (250 \text{ psi})}{(8500 \text{ ft})} \\ &= 0.636 \text{ psi/ft} \end{aligned}$$

Hence the new mud weight would be as:

$$\rho_m = \frac{0.636 \text{ psi/ft}}{0.052 \times 1 \text{ ft}} = 12.23 \text{ ppg}$$

**Example 5.3:** Determine the kill mud density and kill mud gradient for a shut-in-drillpipe pressure of 600 psi at a depth of 12,000 ft. If the original mud weight is 14.5 ppg and the slow circulating pump pressure is 850 psi, find out also the initial and final circulating pressure of the system.

**Solution:****Given data:**

- $P_{sidp}$  = shut-in drillpipe pressure = 600 psi
- $H_{vc}$  = total vertical height of the mud column 12,000 ft
- $r_{om}$  = original mud weight = 14.5 ppg
- $P_p$  = slow circulating pump pressure = 850 psi

**Required data:**

- $r_{km}$  = kill mud weight, ppg
- $G_k$  = kill mud gradient, psi/ft
- $P_{ic}$  = initial circulating pressure, psi
- $P_{fc}$  = final circulating pressure, psi

The kill mud weight can be calculated using Eq. (5.12) as

$$\rho_{km} = \frac{P_{sidp}}{0.052 H_{vc}} + \rho_{om} = \frac{(600 \text{ psi})}{0.052 \times (12,000 \text{ ft})} + (14.5 \text{ ppg}) = 15.5 \text{ ppg}$$

If we consider an overkill mud weight of 0.5 ppg as a safety margin, kill mud weight can be calculated using Eq. (5.13) as:

$$\rho_{km} = \rho_{om} + \frac{P_{sidp}}{0.052 H_{vc}} + \rho_{ok} = 15.5 + 0.5 = 16.0 \text{ ppg}$$

The kill mud gradient can be calculated using Eq. (5.14) as

$$\begin{aligned} G_k &= 0.052\rho_{om} + \frac{P_{sidp}}{H_{vc}} = 0.052 \times (14.5 \text{ ppg}) + \frac{(600 \text{ psi})}{(12,000 \text{ ft})} \\ &= 0.804 \text{ psi/ft} \end{aligned}$$

If we consider there is no overkill pressure, the initial circulating pressure is calculated using Eq. (5.5) as:

$$P_{ic} = P_{sidp} + P_p + P_{ok} = (600 \text{ psi}) + (850 \text{ psi}) + 0 = 1450 \text{ psi}$$

Final circulating pressure is calculated is calculated using Eq. (5.6) as:

$$P_{fc} = P_p \left( \frac{\rho_{km}}{\rho_{om}} \right) = (850 \text{ psi}) \times \left( \frac{15.5}{14.5} \right) = 908 \text{ psi}$$

### Kick Analysis

The composition of the kick fluids controls the annular pressure profile. This pressure profile is normally observed during well control operations. In general, a liquid kick has lower annular pressures than a gas kick. This is true because of the two factors: i) a gas kick has a lower density than a liquid kick, and ii) a gas kick must be allowed to expand as it is pumped to the surface. Both factors result in a lower hydrostatic pressure in the annulus. Thus, it maintains a constant formation pressure. In such cases, a higher surface annular pressure must be maintained using the adjustable choke.

The kick composition must be identified for annular pressure calculations which are needed for well planning. Generally, it is not known during actual well control operations. However, density of the kick fluid can be estimated from the observed drillpipe pressure, annular casing pressure, and pit gain. The density calculation often determines whether the kick is mainly gas/liquid or not. The density of the kick fluid that enters the annulus is estimated simply assuming as a slug. Figure 5.5 shows the initial well conditions after closing the BOP on a kick. The pit gain is usually recorded by pit volume monitoring equipment.

The length and density of the kick can be calculated based on annulus capacity behind the drill collar. If the pit gain volume is smaller than the annulus volume against the drill collar, the length of the kick zone (i.e., influx height) can be expressed in terms of the pit gain volume, and annulus capacity. Mathematically,

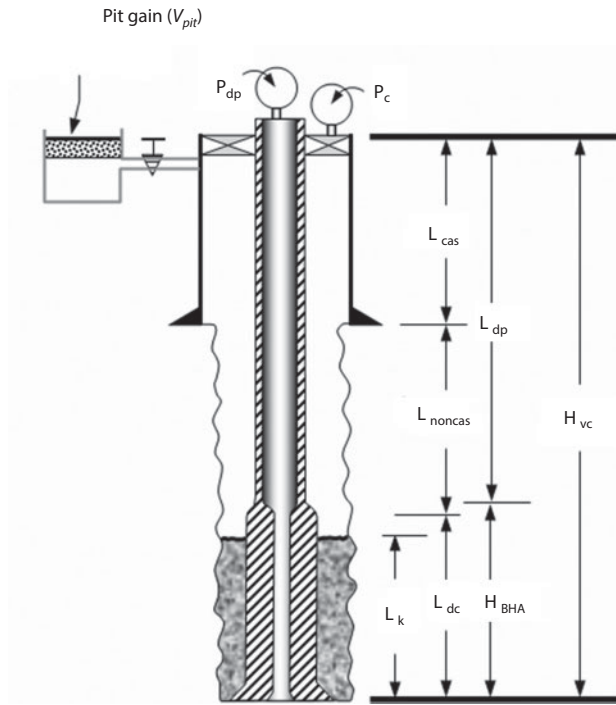

**Figure 5.5** Schematic of initial well conditions during well control operations (Hossain and Al-Majed, 2015).

If  $V_{pit} < V_{ann\_dc}$ , the length of the kick can be calculated as:

$$L_k = \frac{V_{pit}}{C_{ann\_dc}} \tag{5.15}$$

where,

- $L_k$  = kick length (i.e., vertical height of influx,  $H_i$ ), ft
- $C_{ann\_dc}$  = the annulus capacity behind the drill collar, bbl/ft
- $V_{pit}$  = the pit gain volume, bbl
- $V_{ann\_dc}$  = the annulus volume against drill collar, bbl

If  $V_{pit} > V_{ann\_dc}$ , the length of the kick is given by

$$L_k = L_{dc} + \frac{V_{pit} - V_{ann\_dc}}{C_{ann\_dp}} \tag{5.16}$$

where,

$$\begin{aligned} L_{dc} &= \text{length of the drill collar, ft} \\ C_{ann\_dp} &= \text{the annulus capacity behind the drillpipe, bbl/ft} \end{aligned}$$

A pressure balance on the initial well system for a uniform mud density,  $\rho_m$ , is given by

$$P_{icp} + 0.052[\rho_{om}(H_{vc} - L_k) + \rho_k L_k - \rho_m H_{vc}] = P_{idp} \quad (5.17)$$

where,

$$\begin{aligned} P_{icp} &= \text{initial stabilized drill collar pressure, psi} \\ P_{idp} &= \text{initial stabilized drillpipe pressure, psi} \\ \rho_k &= \text{kick fluid (i.e. influx) density, ppg} \end{aligned}$$

Solving Eq. (5.17) for kick fluid density gives

$$\rho_k = \rho_{om} + \frac{P_{idp} - P_{icp}}{0.052 L_k} \quad (5.18)$$

A kick density less than about 4 ppg should indicate that the kick fluid is predominantly gas, and a kick density greater than about 8 ppg should indicate that the kick fluid is predominantly liquid.

**Example 5.4:** A kick was detected while drilling a high-pressure zone. The depth of the formation was recorded 10,000 ft with a mud density of 9.0 ppg. The crew shut-in the well and recorded the pressure for drillpipe and drill collar as 350 psi and 430 psi respectively. The observed total pit gain was 6.0 bbl. The annular capacity against 950 ft of drill collar is 0.028 bbl/ft and the overkill safety margin is 0.50 ppg. Compute the formation pressure, influx density, the type of fluid, required kill mud weight, and kill mud gradient.

**Solution:**

**Given data:**

$$\begin{aligned} H_{vc} &= \text{total vertical height of the mud column} = 10,000 \text{ ft} \\ \rho_{om} &= \text{original mud weight} = 9.0 \text{ ppg} \\ P_{sidp} &= \text{shut-in drillpipe pressure} = 350 \text{ psi} \\ P_{sidc} &= \text{shut-in drill collar pressure} = 430 \text{ psi} \\ V_{pit} &= \text{pit gain volume} = 6 \text{ bbls} \\ L_{dc} &= \text{length of drill collar} = 950 \text{ ft} \end{aligned}$$

$$C_{ann\_dc} = \text{the annulus capacity behind the drill collar} = 0.028 \text{ bbl/ft}$$

$$r_{ok} = \text{overkill mud as a safety margin} = 0.5 \text{ ppg}$$

**Required data:**

$$P_{bh} = \text{formation pressure, psi}$$

$$r_k = \text{kick fluid or influx density, ppg}$$

Type of fluid

$$r_{km} = \text{kill mud weight, ppg}$$

$$G_k = \text{kill mud gradient, psi/ft}$$

Formation pressure can be calculated using Eq. (5.11) as

$$P_{bh} = P_{sidp} + 0.052 \rho_{om} H_{vc} = (350 \text{ psi}) + 0.052 \times (9.0 \text{ ppg}) \times (10000 \text{ ft})$$

$$P_{bh} = 5030 \text{ psi}$$

To calculate the kick density, we first need to calculate the length of the kick and therefore, the annular volume.

The annular volume against the drill collar,

$$V_{ann\_dc} = L_{dc} \times C_{ann\_dc} = 950 \text{ ft} \times 0.028 \frac{\text{bbl}}{\text{ft}} = 26.6 \text{ bbl}$$

If  $V_{pit} < V_{ann\_dc}$ , the length of the kick can be calculated using Eq. (5.15) as:

$$L_k = \frac{V_{pit}}{C_{ann\_dc}} = \frac{(6.0 \text{ bbl})}{(0.028 \text{ bbl/ft})} = 214.29 \text{ ft}$$

The density of the kick fluid is calculated using Eq. (5.18) as:

$$\rho_k = \rho_{om} + \frac{P_{idp} - P_{icp}}{0.052 L_k} = (9.0 \text{ ppg}) + \frac{(350 \text{ psi} - 430 \text{ psi})}{0.052 \times (214.29 \text{ ft})}$$

$$= 1.82 \text{ ppg}$$

Therefore, the kick fluid is **gas**.

Consider overkill mud as a safety margin, the kill mud weight can be calculated using Eq. (5.13) as:

$$\begin{aligned}\rho_{km} &= \rho_{om} + \frac{P_{sidp}}{0.052 H_{vc}} + \rho_{ok} \\ &= (9.0 \text{ ppg}) + \frac{(350 \text{ psi})}{0.052 \times (10,000 \text{ ft})} + (0.5 \text{ ppg}) \\ &= 10.17 \text{ ppg}\end{aligned}$$

The kill mud gradient can be calculated using Eq. (5.14) as:

$$\begin{aligned}G_k &= 0.052 \rho_{om} + \frac{P_{sidp}}{H_{vc}} = 0.052 \times (9.0 \text{ ppg}) + \frac{(350 \text{ psi})}{(10,000 \text{ ft})} \\ &= 0.503 \text{ psi/ft}\end{aligned}$$

**Example 5.5:** A well was being drilled at a high-pressure zone of 12,000 ft vertical depth where 9.5 ppg mud was being circulated at a rate of 8.0 bbl/min. A pit gain of 95 bbl was noticed over a 3-minute period before the pump was stopped and the BOPs were closed. After the pressures stabilized, an initial drillpipe pressure of 500 psi and an initial casing pressure of 700 psi were recorded by the attendees at the rig side. The annular capacity against 950 ft of drill collar was 0.03 bbl/ft and the annular capacity against 850 ft of drillpipe was 0.0775 bbl/ft. Compute the formation pressure, influx density.

**Solution:**

**Given data:**

- $H_{vc}$  = total vertical height of the mud column = 12,000 ft
- $r_{om}$  = original mud weight = 9.5 ppg
- $q_t$  = original mud circulation rate = 8.0 bbl/min
- $V_{pit}$  = pit gain volume = 95 bbls
- $t$  = time to stop the pump = 3 min
- $P_{sidp}$  = shut-in drillpipe pressure = 500 psi
- $P_{sidc}$  = shut-in drill collar pressure = 700 psi
- $L_{dc}$  = length of drill collar = 950 ft
- $C_{ann\_dc}$  = the annulus capacity behind the drill collar = 0.03 bbl/ft
- $L_{dp}$  = length of drillpipe = 850 ft
- $C_{ann\_dp}$  = the annulus capacity behind the drillpipe = 0.0775 bbl/ft



**Required data:**

- $P_{bh}$  = formation pressure, psi
- $r_k$  = kick fluid or influx density, ppg

A schematic view of the example is shown in Figure 5.6. Formation pressure can be calculated using Eq. (5.11) as

$$P_{bh} = P_{sidp} + 0.052 \rho_{om} H_{vc} = (500 \text{ psi}) + 0.052 \times (9.5 \text{ ppg}) \times (12000 \text{ ft})$$

$$P_{bh} = 6428 \text{ psi}$$

To calculate the kick density, we first need to calculate the length of the kick and therefore, the annular volume.

The total annular volume against the drillpipe and drill collar,

$$V_{ann} = V_{ann\_dp} + V_{ann\_dc} = L_{dp} \times C_{ann\_dp} + L_{dc} \times C_{ann\_dc}$$

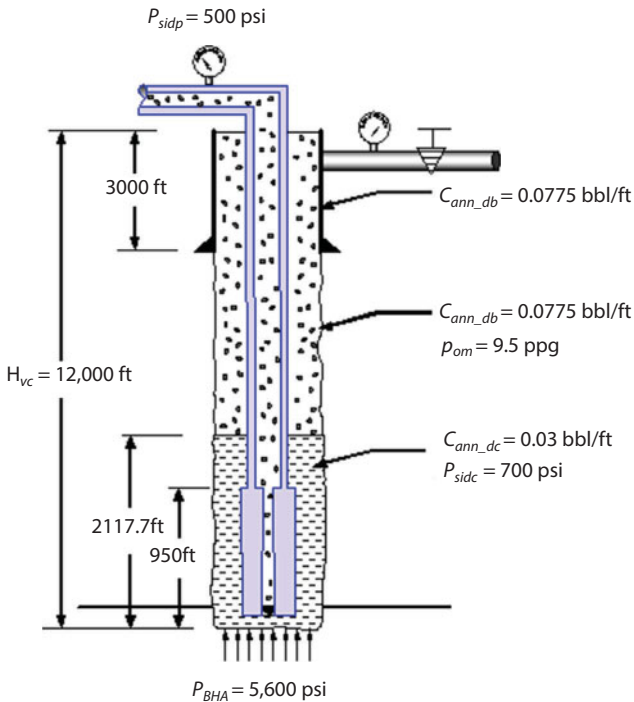

Figure 5.6 Illustration for Example 5.5.

$$V_{ann} = \left( 850 \text{ ft} \times 0.0775 \frac{\text{bbl}}{\text{ft}} \right) + \left( 950 \text{ ft} \times 0.03 \frac{\text{bbl}}{\text{ft}} \right) = 94.37 \text{ bbl}$$

However, kick length is determined based on the total annular volume against the drill collar only. So,

$$V_{ann\_dc} = L_{dc} \times C_{ann\_dc} = \left( 950 \text{ ft} \times 0.03 \frac{\text{bbl}}{\text{ft}} \right) = 28.5 \text{ bbl}$$

If we assume that the kick fluids are mixed with the mud pumped while the well was flowing, so the total pit gain is

$$\begin{aligned} (V_{pit})_{total} &= V_{pit} + q_t t = (95.0 \text{ bbl}) + (8.0 \text{ bbl/min} \times 3 \text{ min}) \\ &= 119.0 \text{ bbl} \end{aligned}$$

If  $(V_{pit})_{total} > V_{ann\_dc}$ , the length of the kick can be calculated using Eq. (5.16) as

$$\begin{aligned} L_k &= L_{dc} + \frac{V_{pit} - V_{ann\_dc}}{C_{ann\_dp}} = (950 \text{ ft}) + \frac{119 \text{ bbl} - 28.5 \text{ bbl}}{0.0775 \text{ bbl/ft}} \\ &= 2,117.74 \text{ ft} \end{aligned}$$

The density of the kick fluid is calculated using Eq. (5.18) as

$$\begin{aligned} \rho_k &= \rho_{om} + \frac{P_{idp} - P_{icp}}{0.052 L_k} = (9.5 \text{ ppg}) + \frac{(500 \text{ psi} - 700 \text{ psi})}{0.052 \times (2,117.74 \text{ ft})} \\ &= 7.68 \text{ ppg} \end{aligned}$$

### Shut-in Surface Pressure

Normally the maximum permissible shut-in-pressure is the lesser of 80–90% of the casing burst pressure and the surface pressure required to produce fracturing at the casing shoe. The maximum permissible shut-in surface pressure is given by the following equation:

$$P_{sifp} = P_{ann\_m} + G_m H_{cs} \quad (5.19)$$

where,

$$\begin{aligned}
 P_{sifp} &= G_f H_{cs} = \text{shut-in fracture pressure, psi} \\
 H_{cs} &= \text{vertical height of the casing shoe or depth to the casing shoe, ft} \\
 P_{ann\_m} &= \text{maximum shut-in annulus pressure, psi} \\
 G_f &= \text{fracture pressure gradient, psi/ft}
 \end{aligned}$$

**Example 5.6:** The surface casing with an OD of 13 $\frac{3}{8}$ " set at a depth of 2,100 ft. The fracture gradient was found 0.68 psi/ft. The mud density was 10.6 ppg with a mud gradient of 0.6 psi/ft. Total depth of the well was 12,000 ft and the internal yield was 2,500 psi. Determine the maximum permissible surface pressure on the annulus. Assume that the casing burst is limited to 85% of design specification.

**Solution:**

**Given data:**

$$\begin{aligned}
 H_{cs} &= \text{depth to the casing shoe} = 2,100 \text{ ft @ } 13\frac{3}{8}" \\
 G_f &= \text{fracture pressure gradient} = 0.68 \text{ psi/ft} \\
 r_m &= \text{mud weight} = 10.6 \text{ ppg} \\
 G_m &= \text{mud pressure gradient} = 0.6 \text{ psi/ft} \\
 H_{vc} &= \text{vertical height of the mud column } 12,000 \text{ ft} \\
 Y_d &= \text{Internal yield} = 2,500 \text{ psi} \\
 &85\% \text{ burst pressure}
 \end{aligned}$$

**Required data:**

$$P_{ann\_m} = \text{maximum shut-in annulus pressure, psi}$$

Figure 5.7 illustrates the wellbore and casing set for the Example 5.6. If the casing burst is limited to 85% of the yield pressure, permissible pressure is then:

$$85\% \text{ burst} = 0.85 \times Y_d = 0.85 \times (2500 \text{ psi}) = 2,125 \text{ psi}$$

The maximum permissible annulus pressure can be determined using Eq. (5.19) as

$$\begin{aligned}
 P_{ann\_m} &= G_f H_{cs} - G_m H_{cs} \\
 &= (0.68 \text{ psi/ft}) \times (2100 \text{ ft}) - (0.6 \text{ psi/ft}) \times (2100 \text{ ft}) = 168.0 \text{ psi}
 \end{aligned}$$

Therefore, the maximum permissible annular pressure at the surface is 168.0 psi, which is that pressure which would produce formation fracturing at the casing seat.

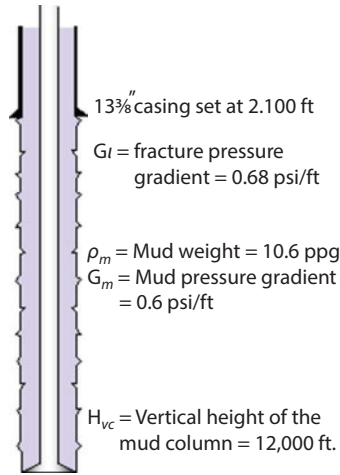

Figure 5.7 Schematic view of the Example 5.6.

**Example 5.7:** What will the kill-weight mud density be for the kick data given below?

- $D_{tv}$  (true vertical depth, bit depth, ft) = 11,550 ft
- $\rho_o$  (original mud weight, lb<sub>m</sub>/gal) = 12.1 lb<sub>m</sub>/gal
- $\rho_{sidp}$  (shut-in drillpipe pressure, psi) = 240 psi
- $\rho_{sic}$  (shut-in casing pressure, psi) = 1,790 psi
- Pit gain = 85 bbl

**Solution:**

$$\begin{aligned} \rho_{kw} \text{ (kill mud weight, lbm/gal)} &= \rho_{sidp} \times 19.23/D_{tv} + \rho_o \\ &= 240 \text{ psi} \times 19.23/11,550 \text{ ft} + 12.1 \text{ lbm/gal} \\ &= 0.4 \text{ lbm/gal} + 12.1 \text{ lbm/gal} \\ &= 12.5 \text{ lbm/gal} \end{aligned}$$

**Steps to Kill Kicks**

- ❑ Initial steps are to mobilize on location cementing pump(s), additional mud storage, and cement batch mixer(s) if available.
- ❑ Mix and store at least one additional hole volume of mud on location.
- ❑ While mixing mud, bullhead water down the annulus to the loss zone to minimize annulus surface pressure and prevent subjecting casing, wellhead and BOPs to gas. This will assist

temperature log interpretation by defining a temperature gradient at the loss zone.

- ❑ Consider running a calibrated rate gyro to provide better relief well targeting. Fracture extension pressure can be estimated by adding surface pumping pressure to water hydrostatic to the loss zone.

The top kill attempt consists of the following steps:

- ❑ Slow annulus pumping rate, continue annular water injection with cementing pump.
- ❑ Pump water or mud down drillstring at 90% of maximum possible rate using rig pumps until pressure stabilizes.
- ❑ Record stabilized pressure and rate. Increase pump rate to maximum and record stabilized pressure and rate.
- ❑ Lost circulation materials can be added to the mud to obtain a static kill after pumps are shut down.
- ❑ If a dynamic kill with water or mud is not achieved, the recorded stabilized two-phase flow pressures developed during the attempted kill, in combination with results of the pressure/temperature log, can be accurately analyzed to determine what will be required.

### 5.2.2 Blowout

Blowout is defined as an uncontrolled release of flowing fluids (e.g., gas, oil, water, and mud) from a well once pressure control systems are completely lost. This uncontrolled flow will be ending up with kick that increases in severity and may result in a “blowout” (Figure 5.8). The well control can only be recovered by: (i) installing or replacing equipment to permit shut-in, or (ii) killing the well or, (iii) drilling a relief well. Blowout can happen during any of the operational phases: (i) drilling phase, (ii) well testing, (iii) well completion, (iv) production, and (v) workover.

There are many factors that cause blowouts. Among those factors, the enormous pressure of the rock formations around an oil reservoir is the most important over all other factors. In general, oil transpires naturally over millions of years where water is compressed and pressurized during this process. The process happens with the carbon-based substance (e.g., life-forms of one type or another) by the layers of sediment that form a composite hydrocarbon bearing zone. Therefore, drillers must take special care during drilling into the rock formation. While drilling, this pressure



Figure 5.8 Schematic view of blowout.

is offset by the utilization of proper mud in the drillstring to balance the hydrostatic pressure. If the pressure maintenance is not properly kept, the formation fluid (e.g., water, gas or oil) can infiltrate the wellbore which can quickly escalate into a blowout if not promptly identified and addressed. If a kick is detected, the first thing that must be done is to isolate the formation fluid entry point by closing in the well, thus reducing the chances of a blowout. A heavier fluid will then be introduced to try and raise the hydrostatic pressure and achieve a balance. Meanwhile, the fluid or gas that infiltrated the wellbore will slowly be evacuated in a controlled and safe manner.

There are three main types of blowouts. They can happen at any time during the drilling process and can have devastating consequences. The blowout can be classified as (i) surface blowout, (ii) subsea blowout, and (iii) underground blowout.

1. **Surface Blowout:** surface blowout is the most common type of blowout and can expel the drillstring out of the well. Sometimes, the force of the formation fluid can be strong enough to damage the rig and surrounding territory. It can also seriously damage the whole area through ignition and

explosion. In addition to oil, the output of a well blowout might include natural gas, water, mud, sand, rocks, and other substances. A blowout can simply happen from sparks of rocks being ejected, or simply from heat generated by friction. Sometimes blowout can be very severe and thus becomes impossible to control directly from the surface specially if there is huge energy in the formation zones which do not deplete considerably over time. In such cases, other nearby wells (i.e., relief wells) are drilled to allow kill mud at a desired depth. If a surface blowout is particularly powerful, it cannot be controlled alone, other nearby wells (known as “relief wells”) are drilled to introduce heavier balancing fluid at depth.

- ii. **Underground Blowout:** an underground blowout is not a common blowout where fluids from high-pressurized formations flow uncontrolled to lower pressure zones within the wellbore. Underground blowout may not necessarily result in the release of oil above ground. However, the formation fluid influx at the wellbore can become overpressured which should be considered during the future drilling plans at the same formation.
- iii. **Underwater Blowout.** Underwater blowout is the most difficult blowout to deal with because of their location. The biggest and deepest underwater blowout in history occurred in 2010 at the *Deepwater Horizon* well in the Gulf of Mexico. The accident was so serious that it forced the industry to anticipate reevaluating its safety procedures.

## 5.3 Case Studies

The following case studies show the severity of the blowout and its consequences on life, assets, and the environment. For each case study presented, we'll discuss the event, how the crisis was solved, the root cause, challenges, and lessons learned.

### 5.3.1 Blowout in East Coast of India

Jain *et al.* (2012) presented a case study on an incident of blowout in India. Even though their focus was safety and environmental impact, this study provided one with some useful tips on drilling operations. The KG Basin is a peculiar petroliferous basin with thick formations under unusually high

formation pressure. The basin was formed following the rifting along eastern continental margin in early Mesozoic. Formation of the series of horst and grabens cascading down towards the ocean led to different reservoir compartments separated by steeply dipping faults. Because most of these faults are sealed or the separation of compartments complete, unusual pressure regimes develop in each of the compartments. In addition, during the Tertiary era, the area became structurally deformed by numerous sets of growth faults and related features. Slope stability was largely impacted due to high sedimentation rates that led to trapping of water in high-pressure pockets. In some areas, the formation pressures have been found to be two times higher than the normal hydrostatic pressure. As the KG basin contains huge gas resources, drilling through these gas reservoirs is of high risk.

An extraordinary blowout took place in an exploratory well in the East Godavari District of Andhra Pradesh in Jan '95. The drilling was initiated in September 1994. The bit sizes and the casing details as well as the well configuration are shown in Figure 5.9.

At the final phase of drilling, the drill bit size was 8 1/2" with a drilling mud specific gravity of 1.3. It was reported that the drill bit was stuck at the depth of  $\approx 2727$  m. After several failed attempts, the drill collar along with drill bit were left behind in order to bypass the tool to continue drilling. It was reported that no kickoff pressure was recorded until this stage. Even though no kickoff pressure was evident, in the evening, uncontrolled flow of gas to the surface at high pressures led to a blowout. The spewing gas caught fire immediately. The remaining pipes inside the bore were thrown out by the enormous pressure of the gas. The gas pressure was estimated to

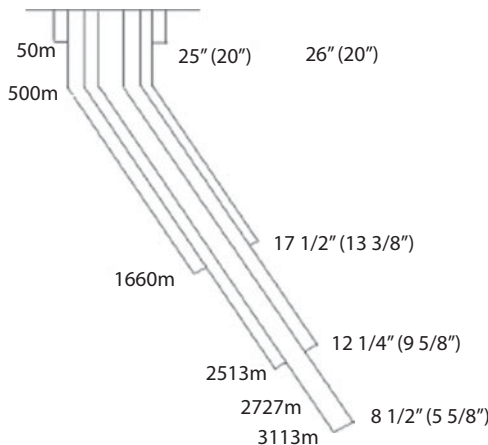

Figure 5.9 Configuration of the well, where the blowout occurred (From Jain *et al.*, 2012).



be 281 kg/cm<sup>2</sup>. The intensity of the fire was high and the noise so piercing that within a radius of 700 m people needed to use ear plugs to prevent immediate physical harm. During the night, the flame of the burning fuel could be visible from more than 2 km from the well site.

### 5.3.1.1 Solutions

As usual, safety measures were taken as the first step of solving the crisis. The following safety measures were immediately put in place.

1. Over 6,000 families evacuated their houses.
2. Decision to combat the flame.
3. Rehabilitate the villagers (evacuation of villagers) and setting up relief camps.
4. Discussion with local administration, government and the public for their coordination and help with the safety rescue personnel.
5. Digging of water storage pits for creating a water umbrella over the flame and cleaning the debris and retrieving the casings, etc., from the well and well site.
6. Mobilize the firefighting equipment from the well site.

The next step involved the gathering of major pieces of equipment and infrastructure in order to remove immediate safety hazards. The following steps were executed based on the mechanical equipment for firefighting and restoration of the well:

1. Six pumps of 20,000 gal/min total capacity were used for spraying of water and to create a water umbrella over the flame to reduce the temperature of the flame and surroundings for approach of the safety rescue personnel and for clearing the debris at the site.
2. To prevent the damage of the pumps, they were placed in the well site.
3. Water monitors were bought for monitoring the level of water in the storage pits. Initially four monitors of 0.1016 ± 0.01 m sizes were used and later on more monitors of 0.023 ± 0.01 m size were received from the United States in the first week of February, 1995.
4. Athey wagon was employed to clear the debris at the well site so that it was easier for the safety rescue personnel to

reach within 20 m radius of the blowout area. This equipment belongs to Halliburton and is used in conjunction with a D-8 or D-9 bulldozer equipped with a hydraulic winch. The winch helps to position the 60-ft. (18.3-m) boom assembly, which is used to remove debris from the vicinity of the well location. It can also be used to kill blowout wells by stinging into tubing or drillpipe. It is also used to mount the abrasive jet cutter on wellhead. Picture 5.1 shows a typical Athey wagon.

5. Two huge water storage pits of 20,000 m<sup>3</sup> total capacity were created. An irrigation canal was present at about 500 m from the site. Water was pumped from irrigation canal to the storage pits.

After gathering necessary pieces of equipment and supplies, an actual solution can be approached. Note that in such an eventuality, one has no time to determine the cause of the blowout with high confidence. It means, procedure should be commenced and a trial and error must be in operation in order to optimize the time required to reach success. History tells us, each operation is unique and there is no way to find the exact reason within a short time frame. So, what appears to be a long-drawn trial and error operation is actually the best option available to engineers.



**Picture 5.1** Athey Wagon.

**Procedures (Success/Failures):** The following procedure was put in place during the course of the well control scheme.

1. Water was sprayed from the storage containers onto the flame to reduce the intensity of the flame for further operations.
2. Drums of plastic explosives of each approximately 200 kg were dispersed over the flame, to deprive the zone of all the oxygen and to extinguish the fire. But many attempts failed.
3. In another attempt, approximately 400 kg of plastic explosive was dispersed onto the flame with the help of Athey wagon and the finally the fire was extinguished.
4. The extinction of fire allowed much-needed relief to the crew and experts at the well site and a capping plan could be executed.
5. In the same month, the final capping operation such as installation of new wellhead and blowout preventers was successful with the help of water umbrella of 98.4 m<sup>3</sup>/min water spray.
6. The surroundings were cleaned with the use of Athey wagon, bulldozer and a crane with hook.
7. A relief well from a distance of 1.5 km from the site of blow-out was drilled to connect to the bottom of the blowout well. High density drilling mud was pumped to control the flow of gas from the reservoir into the well bore.
8. The option of spraying foamy fire retardant chemicals was executed.

#### 5.3.1.2 *Causes of the Blowout*

The causes of blowouts were divided into two categories. Those in the first category (Works, 1944) are few in number and their probability of occurrence is slight. On the other hand, blowouts can also occur unpredictably that place stress upon the control equipment in excess of even the most conservative allowance for factors of safety. In this section, importance has been given to the second type of causes rather than to the first type. In the second type, emphasis is given to the causes relevant to the stuck up of drillstring which lead to the blowout in the KG basin. Stuck up of drillpipe may be due to various reasons (Blok, 2010) as the subsurface rock layers are much diversified in their nature and composition. In plastic formations, such as salt dome, if the pressure caused by the drilling mud is lower than the formation pressure, the formation deforms causing the hole to

collapse as salt is visco-elastic in nature. Reaction of clay minerals with the drilling mud causes swelling and sloughing that cause well bore problems and result is pipe stuck up.

The other type of stuck up which causes blowouts is due to differential pressure. This occurs in open hole when the pipe encounters a permeable formation having a pore pressure much less than the pressure caused by the drilling fluid. In this case, the string is held in place due to the differential pressure. This situation can be recognized by increased over pull on connections due to increase in frictional forces in the well bore. The above situation was encountered in KG basin and was confirmed by stretch test as described in the event summary.

### 5.3.1.3 *Lessons Learned and Recommendations*

The following lessons can be cited:

1. Compartmentalization was known in that area, along with the high-pressure nature of the formation. The drilling mud design should have been based on worst-case scenario.
2. Data were available on ROP, mud pressure, reduced pressure between mud pressure and pore pressure, and mud pit volume. They should have been monitored continuously before jumping to the conclusion that led to the decision of shearing the drill bit and drill collar unit.
3. The rough depth estimate of high pressure zones should have been known from exploration geologists before drilling a well. As the drilling was being carried out, data should have been used to fine tune estimates in real time.
4. Drilling through shallow gas sands require real-time monitoring and the presence of a specialty team available on a 24-hour a day basis. Because of the nature of the formation, such eventualities should have been expected.

The following recommendations for future operations are made:

1. For a formation with abnormal pressure occurrence as well as an exploratory well, 3D data should be acquired in as much detail as possible, including 3D seismic. In addition, a crude form of reservoir characterization should be performed and the drilling operation designed based on the worst-case scenario.

2. Operational data, involving pipe pressure, annulus pressure, mud volume, drilling cuttings, and others should be shared in real time with the geologist and driller. For an exploratory well, a 24-hour readiness should be in place well before the formation is struck.
3. There are various reservoir and well parameters such as pore pressure, bottom-hole pressure to be maintained and initial pumping pressure and mud density should be calculated while killing the well.
4. The prevention of blowout lies in the hands of the operators and their personnel. There is no alternative to have a team with extensive training in blowout prevention and post-blowout management.
5. An inventory of local resources should be ready before the drilling operation is commenced in case of eventualities.

### 5.3.2 *Deepwater Horizon Blowout*

The Gulf of Mexico oil blowout was the most spectacular catastrophe in recent history and captured the attention of the entire world, the effect of which continued to be felt for years after the tragedy. This event has brought to the forefront the adequacy (or inadequacy) of modern drilling technologies (Smith, 2010). Despite numerous publications on the topic, the complete picture of the catastrophe remains a mystery (Biello, 2015). Biello (2015) reported that the U.S. federal government's initial estimate concluded that 4.9 million barrels of oil spilled from the Macondo well over 87 days, of which 17% was captured at the wellhead, 25% evaporated or dissolved and 32% was burned, skimmed or dispersed chemically or naturally. That left more than one million barrels out there as tar mats, tar balls, plumes or buried in sand and sediments. The failure of engineering turned out to be a legal nightmare. Although a federal judge ruled in 2015 that the well spewed just four million barrels in total, he also concluded that more than three million barrels entered Gulf waters, much of which remains out there.

**The Blowout:** In 2008, the multinational energy company BP leased a piece of seafloor in the Gulf of Mexico about 80 km (50 miles) from Louisiana's southern shore. The plot was named Macondo after a fictional town hewn from a "paradise of dampness and silence" in Gabriel García Márquez's novel *One Hundred Years of Solitude*. To do the drilling, BP hired the global drilling company Transocean and its drilling rig *Deepwater Horizon*. The

rig itself was nearly 122 m (400 ft) tall, its drilling platform bigger than a football field (Safina, 2011).

At the time that the infamous blowout happened, oil companies had been drilling in ocean depths of approximately 1,500 meters for more than a decade, but not once had a similar problem occurred. In just the last decade, the number of wells in water deeper than a mile has gone from only two dozen to nearly 300. Increasing complexity increases risks; minimizing challenges in order to successfully overcome them creates a tendency to downplay risks. Unfortunately, such rapid advancement also creates false confidence, hindering preparedness in an unlikely case of a disaster.

On April 20, 2010, BP-operated Mocondo prospect encountered an insurmountable crisis. The disaster was triggered by a “blowout”, causing fire, which was extinguished but crude oil and gas continued to gush out and quickly spread over the surface of the ocean toward the Louisiana coast. What followed is considered to be the largest marine oil spill in the history of the petroleum industry and estimated to be 8% to 31% larger in volume than the previous largest, the Ixtoc I oil spill, dating back to 1979.

At approximately 9:45 p.m. CDT, on 20 April 2010, high-pressure methane gas from the well entered the drilling riser and suddenly got decompressed into the drilling rig, where it quickly ignited and exploded, engulfing the platform. At the time, 126 crew members were on board, only seven being BP employees, 79 of Transocean, and employees of various other companies. Eleven missing workers were never found despite a three-day U.S. Coast Guard (USCG) search operation and are believed to have died in the explosion. The *Deepwater Horizon* sank on the morning of 22 April 2010. This blowout caused the largest oil spill in U.S. history and accounted for the biggest litigation in the history of the petroleum industry. Soon after the blowout, before the well was contained, BP sued and was counter-sued by Transocean, which owned and operated the *Deepwater Horizon* rig, and Halliburton, which supplied the cement intended to plug the well.

A criminal investigation by the Deepwater Horizon Task Force into matters related to the April 2010 Gulf oil spill was launched. This task force, based in New Orleans, was supervised by Acting Assistant Attorney General Mythili Raman and led by John D. Buretta, who served as the director of the task force. The task force included prosecutors from the Criminal Division and the Environment and Natural Resources Division of the Department of Justice; the U.S. Attorney’s Office for the Eastern District of Louisiana and other U.S. Attorneys’ Offices; and investigating agents from the FBI; Department of the Interior, Office of Inspector General; Environmental Protection Agency, Criminal Investigation Division; Office of Inspector

General; National Oceanic and Atmospheric Administration, Office of Law Enforcement; U.S. Coast Guard; U.S. Fish and Wildlife Service; and the Louisiana Department of Environmental Quality.

### 5.3.2.1 Solutions

The immediate reaction to this massive failure was disbelief and a blame game. Soon, BP took a series of short-term measures, none of which was successful. They are listed below.

1. BP attempted to close the blowout preventer valves on the wellhead with remotely operated underwater vehicles. Note that, such an operation would be the first line of action in case of a blowout.
2. A 125-tonne (280,000 lb) containment dome was placed over the largest leak in order to collect the effluent inside a storage vessel with a flow line. This technique had been successful on previous occasions, albeit in shallower waters. In this current situation, the same technique did not work because cooler temperature (due to water Joule-Thomson effect of depressurized gas as well as colder ambient temperature) led to the formation of methane gas hydrates that plugged the opening at the top of the dome.
3. It was then decided to pump ultra dense drilling fluids into the blowout preventer to restrict the flow of oil before sealing it permanently with cement (“top kill”). Three separate pumping efforts and 30,000 barrels of mud along with 16 different bridging material shots also failed. The “top kill” attempt to stop the flow did stop the effluent but only as long as the pumping was being carried out. As soon as the pumping was stopped, the leak continued. Figure 5.10 shows the perceived configuration of the wellbore and how crude was leaking.
4. BP then inserted a riser insertion tube into the pipe and a stopper-like washer around the tube plugged at the end of the riser and diverted the flow into the insertion tube. The collected gas was flared and oil stored on board the drillship *Discoverer Enterprise*. Work went on to optimize the oil and gas collected from the damaged riser through the riser insertion tube tool (RITT). The RITT was a new technology and both its continued operation and its effectiveness

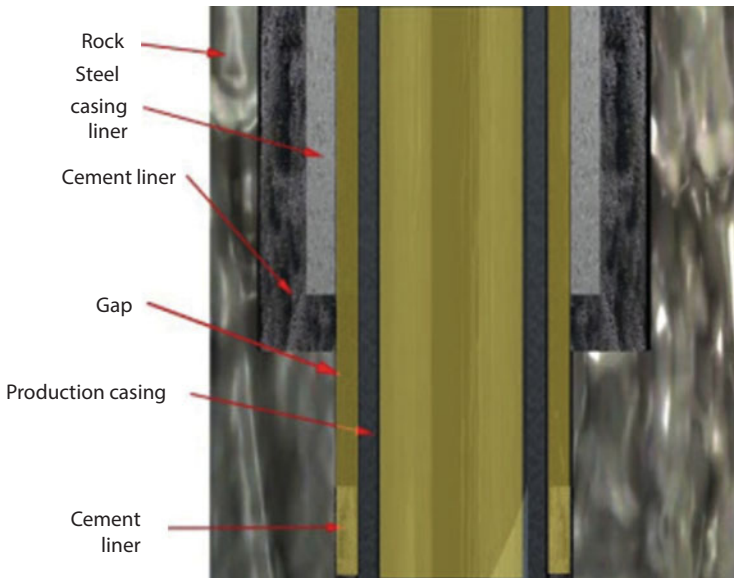

**Figure 5.10** Section through the well shows the path of oil channels that had to be plugged with mud, and then cement.

in capturing the oil and gas remained questionable, despite showing some positive results in the beginning. In the period from May 17<sup>th</sup> to May 23<sup>rd</sup>, the daily oil rate collected by the RITT had ranged from 1,360 barrels of oil per day (b/d) to 3,000 b/d, and the daily gas rate had ranged from 4 million cubic feet per day (MMCFD) to 17 MMCFD. In the same period, the average daily rate of oil and gas collected by the RITT containment system at the end of the leaking riser had been 2,010 barrels of oil per day (BOPD) and 10 MMCFD of gas. While the oil was being stored, the gas being and flared on the drillship *Discoverer Enterprise*, on the surface 5,000 feet above. Before the tube was removed, it collected 924,000 US gallons (22,000 bbl; 3,500 m<sup>3</sup>) of oil. On 3 June 2010, BP removed the damaged drilling riser from the top of the blowout preventer and covered the pipe by the cap which connected it to another riser. On 16 June a second containment system connected directly to the blowout preventer began carrying oil and gas to service vessels, where it was consumed in a clean-burning system. The U.S. government's estimates suggested the cap and other equipment were capturing less than half of the leaking oil.





**Figure 5.11** Arm of a remotely operated vehicle works at the *Deepwater Horizon* oil spill site in the Gulf of Mexico (Source: BP PLC).

5. On July 10, the containment cap was removed to replace it with a better-fitting cap (“Top Hat Number 10”). Mud and cement were later pumped in through the top of the well to reduce the pressure inside. This attempt also failed.
6. A final device was created to attach a chamber of larger diameter than the flowing pipe with a flange that bolted to the top of the blowout preventer and a manual valve set to close off the flow once attached. On July 15, the device was secured with robotic arms (Figure 5.11) by removing the cap from the gushing well. As the final measure of the temporary operation, the cap was replaced.

As a desperate measure to contain the well, an option of using explosives, including a hydrogen bomb was contemplated. Several experts argued that the Soviet Union, in the past, had contained gas well blowouts with nuclear explosions. However, despite recurring rumors to the contrary, BP declared on May 24, that such options could not be considered because if it failed, “we would have denied ourselves all other options.”

In the meantime, two relief wells were being drilled soon after the disaster took place. The first relief well started on May 2, 2010, and on May 16, 2010, a second well drilling was commenced. Modeling studies were sanctioned in order to assess the dangers involved in shutting down the

well that might then leak from underground through downhole valves that were perceived to be damaged and beyond repair. In addition, the possibility of an underground blowout was also considered. At this stage, the following operations took place (Hickman *et al.*, 2012).

1. Mid-June, a well integrity team (WIT) was formed that recommended that BP be allowed to shut the Macondo Well in for a limited-duration well integrity test. After considering a variety of reservoir, wellbore flow/leakage, and hydraulic fracture propagation models, government and BP scientists agreed on a protocol for the test that would use wellhead pressure after shut in (as measured by accurate pressure gauges installed within the capping stack) as a proxy for the integrity of the well. It was determined that, if the pressure after shut in leveled off at less than 6,000 psi (41 MPa), the well needed to be reopened within 6 h. The well in that case would be considered to be losing pressure somewhere below the seafloor, probably through burst and highly eroded rupture disks, and hydrocarbons were likely leaking into surrounding formations. However, if the well shut-in pressure exceeded 7,500 psi (52 MPa), then the test could continue for at least 48 h. In this case, the well would be confirmed to show integrity, leading to the belief that a shut in would be safe. On the other hand, if the pressure were to be in between these two values, the scientists and engineers would face a dilemma, with at least two possible explanations for the results. One explanation was that some of the rupture disks failed and that the well was slowly leaking into surrounding formations. Another explanation was that the reservoir was more depleted than originally anticipated, thus causing the shut-in pressure to be lower than expected. It was agreed that the shut-in pressure leveled off between 6,000 and 7,500 psi. The well integrity test could safely last for 24 h, even with a slowly leaking well, to try to determine which of the above explanations was the correct one.
2. July 15, 2010, the government and BP took advantage of a long window of stable weather to install the capping stack, and the well integrity test began on the afternoon of July 15, 2010. The shut-in procedure consisted of a series of valve turns separated by 10-min rest periods to reduce the oil discharge rate to zero in a stepwise fashion. Several hours after the final turn

- of the valve was completed and the well was fully shut in, the pressure in the capping stack rose to about 6,600 psi (46 MPa).
3. Although the pressure continued to rise slowly, it became evident that 7,500 psi (52 MPa) would not be reached, and the well integrity test result fell squarely in the uncertain middle range. As discussed earlier, this scenario was the one that would become ambiguous, leading to uncertain decision making. BP interpreted the shut-in pressure to indicate a well with integrity that was tapping a reservoir that had been depleted more than originally anticipated and argued that the well should remain shut in after the initial 24-h test period. However, the government took an abundance-of-caution approach and reasoned that, because a leak was possible, the well should be reopened to the Gulf of Mexico after 24 h to avoid the risk of an underground blowout. The government decided that keeping the well closed beyond 24 h would require additional analysis to support the subsurface integrity of the well. This additional analysis was carried out between July 15 and July 16 with a reservoir simulator, albeit a single-phase groundwater model, MODFLOW.
  4. The U.S. Geological Survey model MODFLOW was used to simulate pressure buildup during the first 6 h of shut in. Because limited information was available about the lateral extent of the reservoir, it was assumed to occupy a square area centered on the Macondo Well and bounded by impermeable sides. This simplified representation was considered adequate, because the model would initially be used to simulate only the first 6 h after shut in. During this period, pressure recovery occurred in the close vicinity of the well, and the shut-in pressure was insensitive to the location of the reservoir boundaries. This can be seen in Figure 5.12. This figure shows that the wellhead pressure measured during and immediately after closure of the capping stack on the Macondo Well on July 15, 2010, as measured by pressure gauges installed on the capping stack (PT\_3K\_1 and PT\_3K\_2) compared favourably. Modeling results were obtained by assuming a well with no leaks. The close match between observed and simulated pressures indicated that there was a reasonable scenario in which the Macondo Well had full integrity (i.e., no leakage after shut in), but the oil reservoir had been significantly depleted during the blowout,

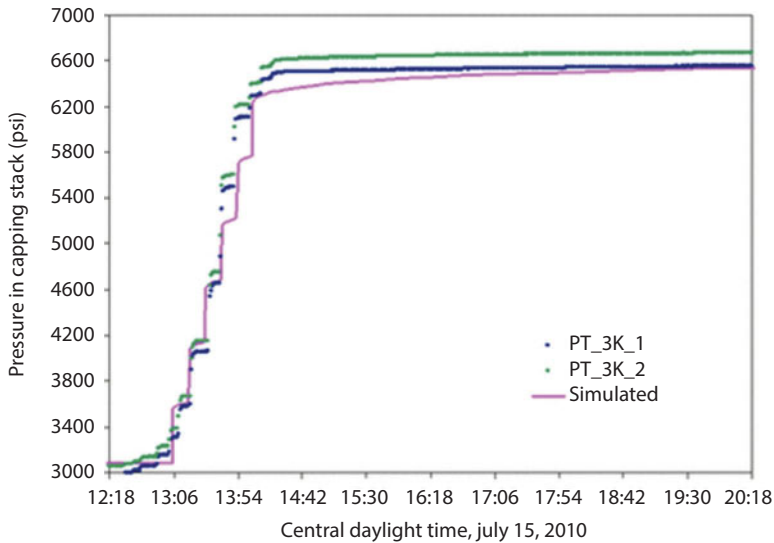

**Figure 5.12** Comparison between observed and simulated pressure build-up.

as claimed by BP. Although the possibility of a leak could not be ruled out, the decision was made by the government to extend the shut in beyond 24 h. As shut in continued beyond 24 h, additional shut-in pressure data were used to update the reservoir model. After about 2 d of shut in, it became apparent that the initial model needed to be revised.

5. A Horner plot analysis of the pressure data (Figure 5.13) indicated that the oil reservoir could be more appropriately modeled as a long, narrow channel (linear) instead of a square. This revised reservoir geometry was more consistent with the known geology of the Gulf of Mexico and the depositional setting of the Macondo Reservoir.
6. Figure 5.13 is equivalent to history matching, with line represented simulation results. This match was obtained only after some adjustment of the reservoir permeability and formation compressibility values. Also, the oil discharge rate used in the model was revised from 55,000 to 50,000 bbl/d (from 8,700 to 7,900 m<sup>3</sup>/d), the most up-to-date estimate by scientists from the Department of Energy National Laboratories during late July of 2010. With increasing availability of pressure data as shut in continued, the model was able to fit the shut-in pressures, and the uncertainty in

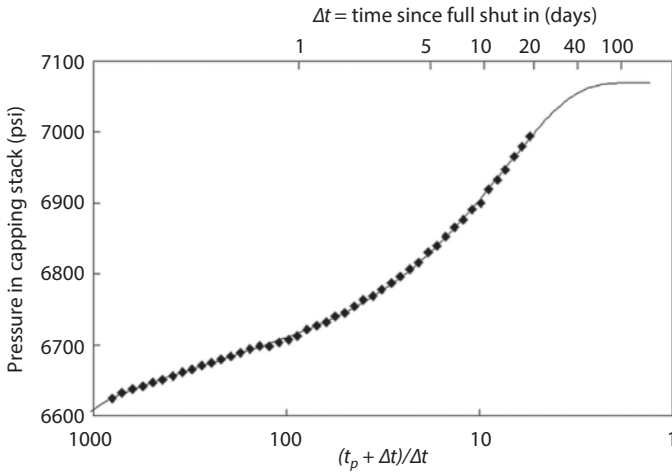

**Figure 5.13** Horner plot of wellhead pressure after closure of the capping stack on the Macondo Well.

projected pressure narrowed. The pressures simulated by the revised model closely match the observed pressures through August 3, 2010, when final well kill and cementing operations began. The good fit between observed and simulated pressures throughout this shut-in period provided continued support for the idea that the Macondo Well had maintained its integrity.

7. Wellhead pressure and geophysical monitoring data were independently reviewed and discussed by BP and the government oversight team, initially at 6-h intervals and then at 12- and 24-h intervals, to determine if the well should remain shut in. If signs of leakage were detected, then the Macondo Well would be immediately reopened.
8. On August 4, 2010, BP began pumping cement from the top, sealing that part of the flow channel permanently.
9. On September 3, 2010, the 300-ton failed blowout preventer was removed from the well and a replacement blowout preventer was installed.
10. On September 16, 2010, the relief well reached its destination and pumping of cement to seal the well began.
11. On September 19, 2010, National Incident Commander Thad Allen declared the well “effectively dead” and said that it posed no further threat to the Gulf.

12. Oil slicks were reported in March and August 2011, as well as in March and October 2012, and in January 2013.
13. In October 2012, BP reported that they had found and plugged leaking oil from the failed containment dome, now abandoned about 1,500 feet (460 m) from the main well.
14. In January 2013, BP said that they were continuing to investigate possible sources of the oil sheen. Chemical data implied that the substance might be residual oil leaking from the wreckage.

A number of initial attempts failed in containing the gusher. Even though the well was declared completely sealed on September 19, 2010, later reports suggested that it was still leaking years after. (After several failed efforts to contain the flow, the well was declared sealed on September 19, 2010.) Reports in early 2012 indicated that the well site was still leaking (Kistner, 2011).

### 5.3.2.2 *Reasons Behind the Blowout*

Soon after the blowout, a number of theories were advanced as to why the blowout had occurred. It would be revealed later that a number of factors, including ‘novel’ mud additives that were not vetted out properly before application, However, the most important question, that is why a series of valves in the 450-ton “blowout preventer” (BOP) failed to close off the gusher after it began remains unanswered until today. The BOP, which was placed on the sea floor, could have closed off any gushing well in several ways—such as by plugging a pipe or even by crushing it horizontally until it is cut off. In addition, there was a backup, in which most BOPs have automatic shutoff valves known as “Dead Man” switches that cause the BOPs to close automatically if there is loss of communication from the oil rig. As another backup measure, many BOPs have radio-controlled switches to allow crews to close the valve remotely. However, the *Deepwater Horizon* lacked that device.

Although BP owned the lease, contractors such as Halliburton, which did the cementing jobs that held the well’s liners in place, and M-I SWACO, which dealt with the continually circulated drilling fluids, did almost all of the work. The distance from the rig to the sea floor was just under 1.6 km (1 mi). Sea floor to the bottom of the well: just over 4 km (about 13,368 ft, or 2.5 mi). A total of 5.6 km (18,360 ft) from sea surface to well bottom (>3.5 mi). Humans cannot dive to such depths, so all the work is done remotely. This poses an additional constraint over onshore drilling operations.

Though two-and-a-half miles long, the well's top was just 1 meter wide, while its lower end was 172 mm (7 in). Several cased sections were completed, with some sections reaching 2000 ft in length. Various problems had put the job behind schedule and over budget. In late April 2010, having discovered a commercially valuable reservoir, drillers proceeded to sealing off the well that would be completed at a later date.

During the drilling process, several zones of mudloss were encountered. Viscosifiers were used to prevent mudloss. It turned out, excessive amount of viscosifiers led to the generation of extra amount that needed to be disposed of prior to continuing the drilling. Bringing the material back to land for disposal would have required the expense of transporting it and handling it as hazardous waste. Because regulations allow the mixing of two different types of mud, rig workers sometimes use a different fluid to help them mark or separate the border between two kinds of fluids. When they see such a "spacer" return to the rig, they know they are between two different fluids.

On the day of the blowout, the main tasks were: pump a cement plug hundreds of feet high into the well to seal the hydrocarbons in, and recapture the drilling fluid and displace it with much lighter seawater. As a typical procedure, the rig team lessened pressure on the well by displacing some of the heavy drilling fluid with seawater. Between the fluid and water they used as a spacer the viscous fluid they wanted to dispose of. Combining this disposal with the cementing job was highly unusual.

The test of the cement was to reduce pressure from above, then make certain that no pressure was building in the well from below. The test protocol called for a pressure gauge reading of zero on a particular pipeline to the rig. And that line showed zero pressure. In principle, the operation was going smoothly. However, on a different line, another gauge was showing pressure building. The gauge indicating building pressure was correct. The line showing zero pressure was clogged with the viscous spacer. The increasing pressure indicated that the cement had failed, and that pressurized oil and gas were entering the well. At this point, the rig workers made the mistake of believing the zero gauge while discarding the one that was showing pressure buildup. To make matter worse, they temporarily bypassed other pressure gauges in an effort to discharge the spacer. Had they not bypassed, they would have been warned with the increasing reading on the pressure gauge.

By the time operators realized they had a problem, confusion and issues over authority delayed assessment of its severity and caused hesitation in initiating attempts to activate the blowout preventer or disconnect the rig from the mile-long pipe to the seafloor. They had rerouted the fluid return back onto the rig when large amounts of methane reached the surface. Generator turbines sucked the gas in, causing ignition.

One worker recognized the need to shut down the generators but knew he was not authorized to do so, and consequently did not. The rig's chief electrician has asserted that inhibited audio alarms also inhibited computer-activated emergency shutdown of air vents and power.

The subsequent explosions killed 11 people. They also damaged controls to the blowout preventer and the emergency disconnect system, rendering them unresponsive. More than 100 other people escaped in lifeboats or by leaping into the sea. The rig burned for two days, then sank on April 22, 2010. The broken pipe at the seafloor continued gushing out oil until, after several attempts to cap or clog the well, a new cap succeeded in mid-July.

In summary, human errors played a significant role, but the fact that the cement failed cannot be ignored. Later enquiries would indicate that the cement testing was not adequate as the prevailing conditions in the wellbore were not simulated in the laboratory. There was an overall sense that the project had to be rushed. This has become a typical problem in the petroleum industry.

Review of BP's preparedness documents revealed that major sections of the manual were merely cut-and-pasted from Arctic plans. No one paid attention to them. The region had hundreds of wells drilled and there was a sense of over confidence and no one really took the regulations seriously. It is reflected in the fact that in a region full of oil rigs and warehouses full of hardware, nowhere was there a device for shutting off a leaking pipe 1 mile deep. All the response equipment available was similar to what it had been in the 1970s: booms adequate to contain small spills inside harbors, and dispersant chemicals.

Quickly overcome by minor wind and wave action, the booms did little to contain the oil. About 2 million gallons of chemical dispersants were added to the oil at the surface and at the seafloor. Reasonable people can disagree on whether dispersants should have been used given the absence of any real preparation for stopping a blowout. Previous studies suggest that the use of such dispersants are not desired and can produce long-term consequences. Until today, this remains an issue with the petroleum industry that continues to use chemicals, whose long-term consequences are not known or test results not verifiable.

Although minor blowouts are not uncommon, and more serious ones occur periodically, plans for responding to a blowout were essentially non-existent. Drilling technology had improved radically, but response technology and preparedness had not changed in decades. The various caps that were tried and failed to stop the 2010 blowout were similar to those that failed in 1979 to stop the Ixtoc blowout, which leaked 140 million gallons of oil into the Gulf of Mexico over 9 months. The device that eventually



stopped the Macondo blowout was designed and built specifically for that purpose; critics likened it to responding to a burning building by designing and building a fire truck (Safina, 2011).

### 5.3.2.3 *Lessons Learned and Recommendation*

The *Deepwater Horizon* blowout unravelled numerous problems that are beyond the scope of a driller. We know for a fact that there was potentially criminal negligence from various parties, including Halliburton, which in fact pleaded guilty to destroying evidence (Szoldra, 2013). There has been a criminal plea agreement with Transocean and lawsuit and counter lawsuit. In the end, the parties settled out of court to minimize litigation cost and all criminal proceedings have been halted because of such agreement and pleadings. The down side of this is that the facts remain shrouded in mysteries. In absence of all the facts, it is impossible to fairly list lessons learned and make recommendations for the future.

Here we list the timeline of events listed by USEPA (2016).

- December 15, 2010: Civil complaint of the United States
- February 17, 2012: \$90 million civil settlement with MOEX Offshore 2007 LLC
- February 22, 2012: Court order granting partial summary judgment of liability for the spill
- June 4, 2014: 5th Circuit decision affirming ruling on summary judgment – 5th Circuit Decision June 4, 2014
- November 5, 2014: 5th Circuit decision denying panel reconsideration and affirming summary judgment ruling – Non dispositive Panel Opinion
- January 9, 2015: 5th Circuit order denying petition for rehearing en banc – *Deepwater Horizon* order denying petition for rehearing en banc
- November 15, 2012: \$4 billion criminal plea agreement with BP Exploration & Production EXIT
- January 3, 2013: \$1 billion civil settlement with Transocean Offshore Deepwater Drilling Inc., Transocean Deepwater Inc., Transocean Holdings LLC, and Triton Asset Leasing GmbH (“Transocean”)
- January 3, 2013: \$400 million criminal plea agreement with Transocean EXIT
- September 4, 2014: Phase One Trial: Findings of Fact and Conclusions of Law on Gross Negligence and Willful Misconduct

- January 15, 2015: Phase Two Trial: Findings of Fact on Source Control and the Amount of Oil Spilled
- February 19, 2015: Ruling on Maximum Dollars-Per-Barrel Penalty Amount, as Adjusted by the Penalty Inflation Act
- October 5, 2015: \$14.9 billion civil settlement with BP Exploration & Production
- November 30, 2015: \$159.5 million Civil Penalty Ruling Against Anadarko Petroleum Co.

Keeping in mind the above timeline, we list the lessons learned and recommendations below.

1. Conduct reservoir characterization before starting the drilling, including performing compositional modeling, with all available data of the region.
2. As drilling is performed, collect real-time data to upgrade the simulation model. Had this been the case, one wouldn't have to resort to simplistic modeling with an Aquifer simulator as was the case for BP.
3. Operate on the basis of worst-case scenario.
4. Avoid using cement or mud additives that are not tested under realistic conditions that prevail in the wellsite. In the core of this incident, Halliburton had used cement additives that were not properly vetted under realistic conditions.
5. At no time should a drilling operation be rushed. The disaster could have been avoided if the rig operator wasn't pressed to seal the well in a hurry.
6. Each piece of safety equipment must be tested routinely. It is incomprehensible how a number of most vital components failed to function and still today there is no explanation for those colossal failures.
7. Coordination between various parties must be continuous and cannot wait until an emergency occurs. Such coordination must be rehearsed whenever a number of companies, including contractors, are involved.

## 5.4 Summary

The chapter discusses almost all aspects of well control and monitoring system. How a well can be controlled in a sequential and safe way is well

documented here. What are the different control devices used while drilling are paramount in any well control and monitoring system. These devices and their functions are outlined in this chapter. Well monitoring is an integrated part of the drilling operations. Therefore, parameters that need to be monitored to control the well are identified through this chapter. This chapter covers the whole range of real-time monitoring system and discusses the current practices in the industry and the future trend of the well control and monitoring system in general.

In short, well control is considered one of the most crucial aspects in drilling a gas and oil reservoir. In fact, it affects the overall cost of the well completion and sometimes it leads to fatalities, and numerous or great damage to the environment. Human errors and equipment failure are the cause of blowouts which is uncontrolled of the formation fluids, so well control becomes the most important aspect. In addition, well monitoring is the important aspect in drilling and production. It provides us with a view of what is happening downwards in the well. That is to say, the necessity for the early detection and the control of these kicks, losses and also the other abnormal circumstances while drilling are becoming essential as industry drilling has increased in areas that have a challenging environment onshore and offshore as a result of difficulties with respect to pressure regimes and equipment stresses. Also drillstring monitoring is important aspect in well control.

Case studies are provided in order to identify weak points in the current practices in the petroleum industry. This discussion is necessary to prepare for incident-free drilling operations in the future.

## References

- Biello, D., 2015. The Enduring Mystery of the Missing Oil Spilled in the Gulf of Mexico, *Scientific American*, April 17.
- D. Fraser, K. Kubelsky, J. Braun., An Analysis of Loss of Well Control Events in the Gulf 2007-2013, currently in preparation.
- Deep Water Drilling Risk Reduction Assessment, MIDÉ Technology Corporation, Aug 23, 2010.
- Hickmana, S.H., Hsiehb, P.A., *et al.*, 2012, Scientific basis for safely shutting in the Macondo Well after the April 20, 2010 Deepwater Horizon blowout, *Proceeding of the National Academy of Sciences of the United States of America*, vol. 109 no. 50, 20268–20273, doi: 10.1073/pnas.1115847109
- Hornung, M.R. 1990. Kick Prevention, Detection, and Control: Planning and Training Guidelines for Drilling Deep High-Pressure Gas Wells. SPE/IADC Drilling Conference, 27 February-2 March 1990, Houston, Texas. SPE-19990-MS.

- Kistner, R., 2011. The Macondo Monkey on BP's Back. *Huffington Post*. 30 September 2011.
- Low, E. and Jansen, C. 1993. A Method for Handling Gas Kicks Safely in High-Pressure Wells. *Journal of Petroleum Technology* 45:6 SPE-21964-PA.
- Nas, S. 2011. Kick Detection and Well Control in a Closed Wellbore. IADC/SPE Managed Pressure Drilling and Underbalanced Operations Conference and Exhibition, 5–6 April 2011, Denver, Colorado, USA. SPE-143099-MS.
- National Commission on the BP Deepwater Horizon Oil Spill and Offshore Drilling, p. 165.
- Safina, C., 2011. The 2010 Gulf of Mexico Oil Well Blowout: A Little Hindsight, *PLoS Biol* 9(4): e1001049, April 19.
- Schubert, J.J., A.M.U. Texas and J.C. Wright, 1998. Conoco Inc, Early Kick Detection through Liquid Level Monitoring in the Wellbore: Paper SPE/IADC no. 39400 Presented at the 1998 IADC/SPE Drilling Conference Held in Dallas, Texas 3-6 March 1998.
- Smith, Aaron, 2010. Blowout preventers: Drilling's fail-safe failure, CNN, June 30.
- Szoldra, P., 2013, Halliburton Pleads Guilty to Destroying Evidence in Connection with Deepwater Horizon Oil Spill, *Business Insider*, July 25, 2013.
- US EPA, 2016, website dedicated to *Deepwater Horizon* blowout and follow up, available at <https://www.epa.gov/enforcement/deepwater-horizon-bp-gulf-mexico-oil-spill>

# 6

## Drillstring and Bottomhole Assembly Problems

### 6.0 Introduction

The most important task that the petroleum industry undertakes is connecting the subsurface petroleum-producing zone with the surface. This task is carried out with drilling, which is used to create a hole in the earth subsurface from an infrastructure, called the drilling rig. The drilling rig is dedicated to operating a drillstring, which is typically made up of three sections: Bottomhole assembly (BHA), transition pipe and drillpipe. Drillstring, which in essence includes the drillpipe, the BHA and any other tools used to make the drill bit turn at the bottom of the wellbore, is the backbone of a drilling operation. It must work in harmony with the fluid (mostly mud) system in order to execute drilling. The lower part of the drillstring that connects to the drill bit is called the BHA, which consists of heavy weight drillpipe, drill collar, stabilizers, bit sub, and a bit. At times a mud motor is added to the assembly just before the stabilizer. Also, the components may change depending on the nature of a particular operation. For instance, jarring devices (called “jars”), sonic-while-drilling tools, logging-while-drilling, directional drilling equipment, and others can be

added to the drillstring. In drilling engineering, drilling fluids are driven by the hydraulics, which drives the drillstring, thus forming the core of a drilling operation. In this process, proper estimation of fluid mechanics as well as solid mechanics is the essence of drilling engineering calculations.

Every new drilling operation encounters renewed challenges. As we expand the scope of drilling to cover more challenging terrain, formation, and the environment, it becomes increasingly difficult to maintain a high performance level with regards to drilling speed, tool reliability, overall and drilling dynamics. As the cost of material and technology go up, so does the risk of not optimizing a process. Because the petroleum industry is driven by maximizing the profit, understanding and mitigating any problem is of utmost importance.

In order to optimize the rate of penetration (ROP), the design of downhole and well trajectory, for which the drilling fluid is aligned with drillstring has to be optimized in depth and azimuth. This process of optimization has received a lot of help from the many innovations of recent years. For instance, underbalance drilling, hydraulic ultra-high pressure (UHP) jet assisted downhole drilling, novel cutting-cleaning techniques, incorporation of real-time monitoring and guidance tools all have contributed to more effective and accurate drilling operations. However, as the drillstring becomes increasingly more sophisticated the risk of operational problems also increases. Any problem that arises can add significant threat to the drillstring safety owing to the prevalent harsh operational conditions. For instance, when superior smart material or nanocomposites are used in a drillstring, often the malfunction of a single component can bring on a series of anomalies that are not familiar to the operator and are costly to remedy due to their unique manufacturing traits. Other factors, such as drilling vibration, dissolution of synthetic materials in native fluids, etc., can impact the drilling activity.

The drilling hydraulics provides a productivity tool which is helpful in drilling of hydrocarbon wells for hydraulics calculations, and optimization of ROP to the driller, tool pushers, engineers, chemists, students and other professionals. It can help with the decision involving selection of bit nozzles. In addition, accurate use of hydraulic energy at i) drill bit, ii) calculations of frictional pressure drops through the drillpipe and various surface equipment, iii) efficient cleaning ability of the drilling system, and iv) proper utilization of mud pump horsepower are some of the features necessary to optimize for efficient, safe, and cost-effective drilling operations. An incorrect design resulting in an inefficient hydraulics system can – i) slow down the ROP, ii) fail to properly clean the hole of drill cuttings, iii) cause lost circulation, and finally iv) lead to blowout of the

well. Thus, proper design and maintenance of rig hydraulics is crucial. To understand and properly design the hydraulic system, it is important to discuss hydrostatic pressure, types of fluid flow, criteria for type of flow, and types of fluids commonly used in the various operations at the drilling industry. Hence this chapter deals with the type of fluids; pressure losses in the surface connections, pipes, annulus, and the bit; jet bit nozzle size selection; surge pressures due to vertical pipe movement; optimization of bit hydraulics; and carrying capacity of drilling fluid.

This chapter addresses most operational problems in a drillstring and proposes the solutions. This chapter considers alternative technologies and modifications that should be made to the BHA, to minimize shock, vibration, and other related problems. The chapter is aimed at establishing efficient operating practices involving the drillstring. Also added are several case studies that help understand related field problems and their mitigation.

## **6.1 Problems Related to Drillstring and their Solutions**

### **6.1.1 Stuck Pipe**

In extended reach drilling operations, a stuck pipe can lead to major non-production incidents (Aadnøy *et al.*, 2003). Because of the delay involved as well as the possibility of losing the drillstring, pipe sticking can increase the drilling costs dramatically, leading to an increase of as much as 30%, particularly during offshore operations (Sharif, 1997).

A pipe is considered stuck if it cannot be freed from the hole without damaging the pipe, and without exceeding the drilling rig's maximum allowed hook load. Pipe sticking can be classified under two categories: differential pressure pipe sticking and mechanical pipe sticking (SPE, 2012). Mechanical sticking can be caused by junk in the hole, wellbore geometry anomalies, cement, key seats or a buildup of cuttings in the annulus (Bailey *et al.*, 1991).

Stuck pipe incidents are one of the major operational challenges of the E&P industry and events usually lead to significant amount of lost time and associated costs (Isambourg, 1999). It costs the oil industry between \$200 and \$500 million each year, occurs in 15% of wells, and in many cases, is preventable (Figure 6.1). Stuck pipe remains a major headache that demands and is getting industry-wide attention (Bailey *et al.*, 1991).

Stuck pipe incidents are one of the major operational challenges of the E&P industry and events usually lead to significant amount of lost time

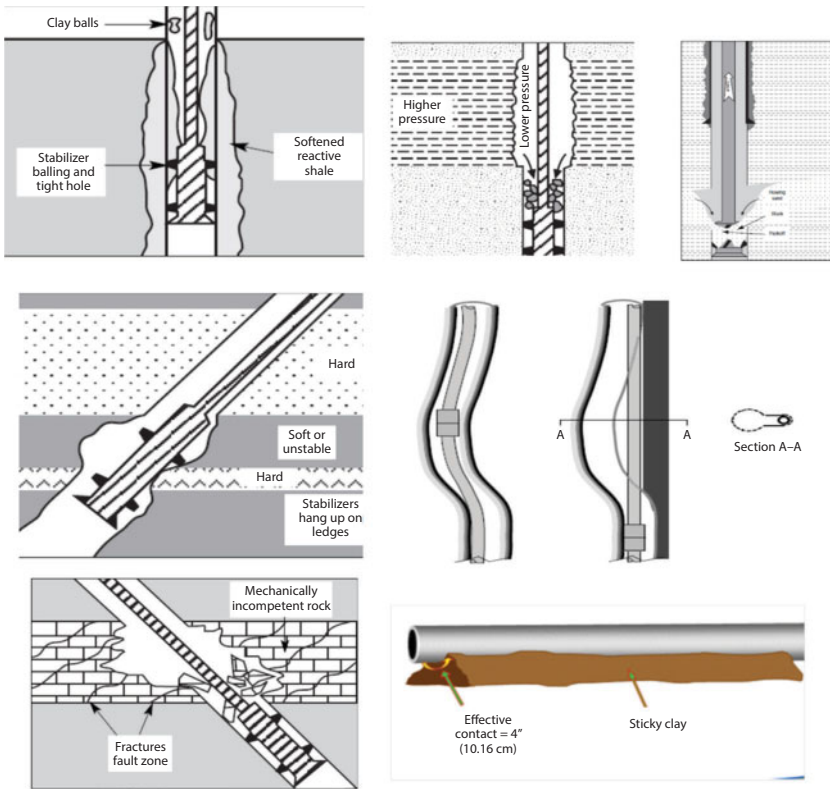

Figure 6.1 Different cases for stuck pipe (from wordpress.com).

and associated costs. Various industry estimates claim that stuck pipe costs may exceed several hundred million U.S. dollars per year. In Saudi Aramco, the recent increase in drilling activity, drilling in depleted and higher-risk reservoirs have led to an increased risk of stuck pipe. In 2010 Saudi Aramco formed a task force to focus on lowering its stuck pipe costs. In its campaign to reduce this cost, the task force selected key personnel from each of the Drilling & Workover (D&WO) operating departments.

6.1.1.1 Free Point – Stuck Point Location

The first step in dealing with a pipe sticking problem is to determine the depth at which the sticking has occurred (DeGeare *et al.*, 2003). Conventionally, two methods are currently in use to determine the location of the stuck point. They are: direct measurements and calculations. Compared with the calculation method, free-point indicators, acoustic log tools, radial cement bond tools, and other measurement tools can be run



down to determine the stuck point or interval with high precision (Russell *et al.*, 2005; Siems and Boudreaux, 2007). However, these methods are time-consuming, expensive, and require special instrumentation down to the bottom hole and qualified operators (Aadnøy *et al.*, 2003). Consequently, the calculation method is preferred and more widely used to estimate the depth at the stuck pipe.

The most commonly used method involves stretching the pipe under a known amount of pull and measuring the distance traveled by the top of the pipe during the stretch. Hooke's law gives the relationship between the extension and axial pull. This formulation, however, neglects wellbore friction and is valid for vertical wells only, unless the pipe is stuck before the directional kick point. In complex wells, such as directional wells, horizontal wells, and extended reach wells, a large error will be manifested in the calculations; this method will produce a large calculation error because wellbore frictions play a significant role and obscure the simplistic relationship, determined by Hooke's law. In order to remedy this shortcoming of calculation methods, Aadnøy *et al.* (2003) considered friction in curved sections and derived equations to combine the effects of axial pull and torsion, which can be determined through torsion tests. Overall, they included the following elements: (i) the forces developed during differential sticking; (ii) pipe strength under combined loads: tension, torque and pressure; (iii) effects of buoyancy under various conditions like equal or different mud densities in drillpipe and annulus; and (iv) wellbore friction as related to torque and drag. By using pull and rotation tests, they concluded that the stuck point appears deeper in a deviated well compared to a vertical well. Their theoretical analysis, supported with experimental evidence differential pressure across the stuck interval is the dominating factor. This finding leads to the conclusion that the most important remedy to free the pipe is to reduce the bottomhole pressure. Such reduction in bottomhole pressure can be achieved either through using a lighter mud or by injecting seawater to displace the mud within the drillstring.

Lianzhong and Deli (2011) improved over the above calculation method. By eliminating simplifying assumptions, such as, either there is no drag or that drag is working everywhere along the drillstring in the same direction, the axial force can be effectively transmitted to the stuck point, etc., they came up with a more complex formulation that can be solved with a computer program. This method overcomes the difficulties involved in directional wells or extended reach wells, for which frictions in the wellbore are pronounced. It takes full account of the down hole friction, the tool joint, the upset end of drillpipe, tubular materials and sizes, and as such is valid for determining the stuck point in extended reach drilling.

In this method, the initial depth to the stuck point is assumed and the drillstring between the surface and the stuck point is then subdivided into a certain number of elements. Using finite difference formulation, torque and drag values are calculated from the surface down to the stuck point with the finite difference method and then it is determined whether the tension and/or table torque can be transmitted to the stuck pipe location. If the answer is “yes”, force increment and deformation of any differential elements are then calculated. Then, pull length and/or twist angle are determined by cumulative calculations. As the flow chart in Figure 6.2 shows, comparison is made between the calculated and observed pull length and/

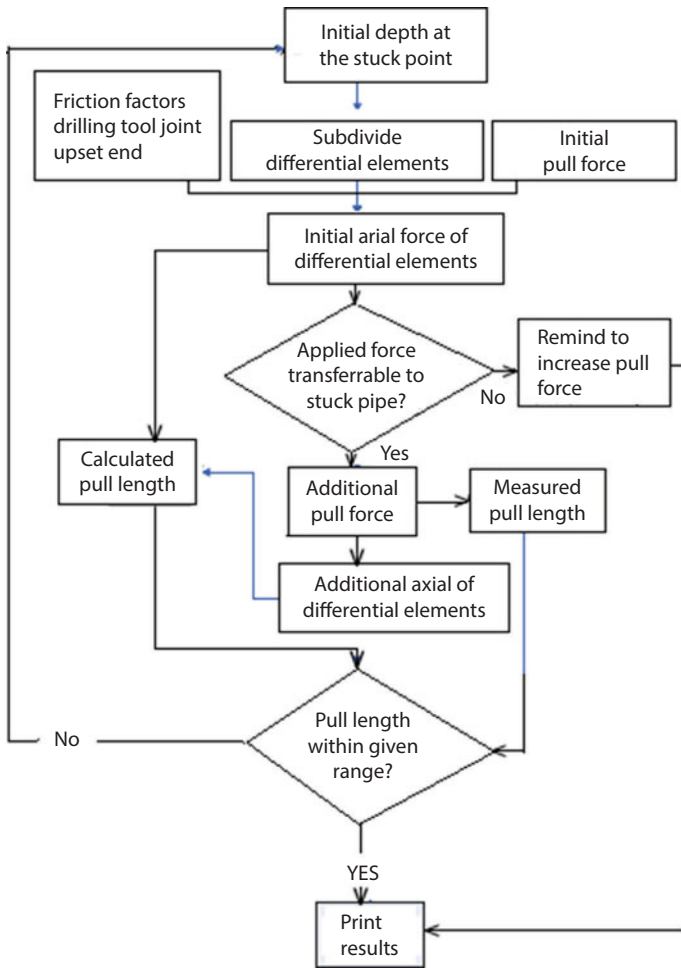

Figure 6.2 Flow chart for determining the location of the stuck pipe.

or twist angle and the process is repeated until convergence occurs, for which a predetermined tolerance is reached. In general, Lianzhong and Deli’s (2011) model confirms the following:

1. Drag has a significant impact on the pull length while pulling the stuck drillstring. The friction factor is inversely proportional to the pull length.
2. Effects of the hook load and the friction on the twist angle are negligible while rotating the stuck drillstring.
3. Due to the tool joint and the upset end, the stuck point calculated is deeper. When the effects are taken into considerations, the pull length or the twist angle calculated is 5% smaller.
4. Compared with the pull tests, the application of Hooke’s law to torsion tests may obtain the stuck point depth with higher accuracy as if the applied force at the surface can be transmitted to the stuck point.

Normally a lubricating fluid is “spotted” in the troublesome area and is used to dissolve the filter cake. But the question is, how can I know the location of the stuck point? (Lapeyrouse, 2002) By using this equation:

$$SPL = (735 \times 10^3) \times \frac{w e}{F_2 - F_1} \tag{6.1}$$

where:

- $SPL$  = Stuck Pipe Location
- $735 \times 10^3$  = Derivation of Young’s Modulus for steel
- $w$  = Drillpipe weight ( $lb_s/ft$ )
- $e$  = Length of stretch (inches)
- $F_1$  = Force applied when pipe is in tension ( $lb_s$ )
- $F_2$  = Force applied to stretch pipe to “ $e$ ” ( $lb_s$ )

### 6.1.1.2 The Most Common Causes of Stuck Pipe

Bailey *et al.* (1991) prescribed the following causes of the stuck pipe.

1. **Differential Sticking:** Any differential pressure between the hydrostatic pressure of mud and formation pressure of mud can become a trouble point when the hydrostatic pressure is greater than the formation pressure. In case of permeable

formation, such pressure differential would push the drillstring into a filter cake of permeable formation. When the differential sticking occurs, the drillpipe cannot be moved up or down. However, free circulation can be established easily. Sticking will occur if six factors are present: (i) a permeable formation, (ii) thick filter cake (due to a high-water loss), (iii) the drillstring is in contact with that filter cake, (iv) an overbalance situation exists, (v) insufficient drillstring movement and, (vi) a lack of circulation between the drillstring and the filter cake.

2. **Geopressed Formations:** If these formations are not permeable (for example, shales), it will “cave” into the borehole.
3. **Reactive Formations:** When tripping, the BHA can become stuck in the smaller diameter (swelled) portions of the borehole. This small diameter occurs when the clays within the shales “gumbo shales” react with the mud filtrate and hydrate.
4. **Unconsolidated Formations:** It occurs when sand and gravel formations collapse into the borehole during drilling.
5. **Mobile Formations:** It occurs in the plastic formations “shales and salt”; during drilling it will trend to flow into the borehole.
6. **Fractured/Faulted Formations:** When the fractured or faulted formation “limestones and shales” is drilled, there will be a tendency for pieces of the formation to fall into the borehole.
7. **Key Seating:** It is an extra hole. This “extra” hole will generally have the I.D. of the drillpipe’s tool joints and the drill collars will not pass through this extra hole when tripping out.
8. **Borehole Geometry (Profile and Ledges):** During tripping operations problems with borehole geometry normally occur: “Ledges and washouts”.
9. **Undergauge Borehole:** The gauge protection on the bit and stabilizers can become so worn it becomes ineffective when drilling long sections of abrasive formations.
10. **Inadequate Hole Cleaning:** Overloading of the annulus is caused in hole cleaning and this results in the formation of a cuttings bed on the low side of the borehole.
11. **Junk in the Borehole:** It is impurity or a foreign object in the borehole, which is not meant to be there.

12. **Cement Blocks:** The large-sized collars or stabilizers can cause blocks of cement to break loose and fall into the borehole after a leak-off test. These large blocks can easily jam against the drillstring.
13. **Green Cement:** This occurs when the cement is not allowed to set properly; the cement does not set properly.

### 6.1.1.3 Prevention of Stuck Pipe

The most commonly used operations to prevent the drillstring from sticking are:

1. Immediately work/jar the drillstring (downwards if possible) and apply right-hand torque “Differential Sticking, Junk in the Borehole, Cement Blocks, “Green Cement”
2. Reducing the hydrostatic pressure may be an option, “Differential Sticking”
3. Involves spotting a friction reducing fluid within the stuck zone, “Differential Sticking”
4. Correcting the situation is to establish circulation, “Geopressured Formations”
5. An increase in the mud density is advisable, “Geopressured Formations”
6. Circulation must be established, “Reactive Formations, Unconsolidated Formations, Inadequate Hole Cleaning, Green Cement”
7. The drillstring should be worked up and down, if possible, “Fractured/Faulted Formations, Key Seating, and Borehole Geometry”
8. Increasing the mud density, if possible, “Reactive Formations, Unconsolidated Formations, and Mobile Formations”
9. An inhibited acid (e.g., HCl) pill can be used to dissolve the limestone, “Fractured/Faulted Formations”
10. The drillstring should be rotated up and out of the key seat with minimum tension, “Key Seating, Inadequate Hole Cleaning”
11. Maximum upwards working/jarring forces should be applied immediately, if the new bit is run into an undergauge hole, “Undergauge Borehole”
12. In low-angle holes, a weighted high viscous pill should be used to “float out” the cuttings, Inadequate Hole Cleaning”

13. An acid solution can be pumped around to dissolve the cement, "Cement Blocks, Green Cement"
14. Clean the hole of cuttings when not drilling, "Geopressured Formations"
15. Carefully monitor swab/surge pressures, "Reactive Formations"
16. Use "eccentric" PDC bits to drill, "Mobile Formations"
17. Minimize dogleg severity, "key seat, Borehole Geometry"
18. Select bits with good gauge protection (5 & 7 feature in roller cone bits), "Undergauge Borehole"

#### 6.1.1.4 *Freeing Stuck Pipe*

The three main causes of stuck pipe are cuttings and cavings, keyseats, and differential sticking. Cuttings and cavings build up in the annulus when mud and hydraulics fail to keep the hole clean. Poor design, deteriorating mud systems, pump failure, holes in the pipe, or many other conditions may give the same result. The drillstring may not move up or down, and circulation may be restricted or absent.

Keyseat sticking generally occurs while the pipe is moving upward. The top of the drill collars, the uppermost stabilizer, and the bit are the most likely parts of the drillstring to hang up in the keyseat, or slot, cut into the dogleg by the downhole assembly. Complete circulation is nearly always present during keyseat sticking, and the pipe is more likely to have freer movement downward than upward.

When the drillstring sticks, work it in the direction opposite to which it was moving when it became stuck. Work it for an extended time, jarring if drilling jars are in the bottom hole assembly and above the free point; do not immediately call for the fishing equipment. Decide what type of sticking is involved, and use stretch table to determine where the free point. If the drillpipe is worn to less than nominal weight, stretch tables may not be accurate. It should be possible to determine if the free point is moving up the hole. If this is the case, it is time to do something else. Continue working the pipe while decisions are being made.

If the stuck-pipe log shows only a small section of the fish to be stuck, a simple fishing assembly may be run rather than a wash-over assembly. Below the drillpipe run four to six drill collars (one for each inch of jar diameter), fishing jars, bumper sub, one drill collar, back-off sub, and tool to catch the fish. This assembly can be used to wash over with washpipe and rotary shoe substituted for the catch tool. A spear may be used between the back-off sub and the washpipe if it is thought possible to wash over to

the bit and remove the fish on the same pass. Do not run over 150 m of washpipe; washing over is a dangerous procedure, although less so in open than in cased hole. Washing over in cased hole is one of the riskiest fishing operations.

#### 6.1.1.5 *Measures to Reduce Stuck Pipe Costs*

Efforts to minimize stuck pipe incidents are not new to the oil industry. In the past, steady efforts have been made by drilling operations to reduce stuck pipe related NPT but the impact had not been consistent. The objective of the task force was to concentrate extra focus to accelerate the reduction of Saudi Aramco's stuck pipe costs (Hopkins *et al.*, 1995; Yarim *et al.*, 2007).

To mitigate and prevent stuck pipe incidents, the team developed the following strategies to tackle the root cause factors:

1. Best practices for stuck pipe avoidance for oil and gas wells.
2. Economics of fishing versus side track scenarios using mathematical models for effective decision making.
3. Stuck pipe awareness posters and certification course. Posters will be strategically displayed to serve as reminders to drilling personnel. Stuck pipe courses will be offered to all frontline drilling personnel with potential for 2 years certification.
4. The Stuck Pipe Reporting Template which provides a consistent platform to analyze stuck pipe incidents thoroughly and highlights effective measures for reducing associated NPT. Stuck pipe knowledge management reporting in drilling database is recommended to capture all incidents.
5. Short- and long-term stuck pipe avoidance initiatives were discussed by the team for either developing and/or acquiring stuck pipe avoidance software for alert/prevention and to be incorporated in the Real Time Operating Center (RTOC) as a long-term action.

#### 6.1.1.6 *Some Examples of Field Practices*

Some of the best practices for stuck pipe retrieval are listed in this section. The following four steps are recommended during the planning phase.

1. Raise the level of awareness of stuck pipe prevention (e.g., certification courses and road shows).

2. Improve response time and methods for treating stuck pipe to lower the average duration of stuck pipe per event to less than 24 hrs. from a current average of 60 hrs.
3. Plan well direction, mud properties and hydraulics in addition to applying enhanced hole cleaning practices to reduce stuck pipe risks.
4. Review BHA design to enhance hole cleaning and optimize jars placement in the BHA where they are most effective when stuck.

The following steps are involved in the preparation of the operational phase.

1. Ensure that all surface pulling equipment is in good working condition. Do not exceed the maximum allowable safe working rating of the weakest link in the pulling equipment.
2. Check the Rig weight indicator and the dead-weight anchor as follows:
  - a. Check the fluid level of the cylinder or sensor and fill the system if necessary, with the correct fluid and hand pump in the cylinder, bleeding air at the connection on the gauge.
  - b. Mount cylinder or sensor with outlets on top.
  - c. Check that the anchor is free to work. The anchor should be greased regularly and the anchor pins kept free of paint and corrosion. Once a week the pins should be pulled, cleaned and greased. The anchor movement should be checked using a pinch bar between the wheel and the stop of the anchor. By applying a force, the gauge should move quickly.
  - d. Check the gauge; read the proper dial which corresponds to the number of lines string. The pointers on the gauge should move freely without touching any other part of the gauge. Ensure that the damper is sufficiently open to allow fluid flow, yet prevent severe movement. Ensure the vernier is closed during trips and when jarring.
  - e. Check the hose for leaks, and ensure that it is not pinched. When moving the indicator, break the hose at the self-sealing union at the cylinder or sensor.
  - f. Calculate the amount of pull to be applied.



The following steps are recommended during the execution phase.

- a. When determining the pull on stuck drillpipe in a vertical hole the actual weight of the string in air is to be used and not the indicated weight as recorded by the weight indicator.
- b. It is customary to pull on stuck pipe up to 85% of the minimum yield strength of the (weakest) pipe in the string, unless otherwise advised by Base.
- c. Either 62.5% of Yield strength of top pipe or thread (take weakest) or 62.5% of Yield strength of weakest pipe or thread + Weight (in air) of casing above it.
- d. Regardless of the calculated allowable loads, the safety factor for the block line shall never be less than 3. This may well be the limiting factor instead of the casing strength.
- e. If there are angle changes in the hole and/or internal pressure inside the casing, the allowable surface load shall be restricted by the factor value in API Bulletin 5C2.

**Stuck Pipe in a Salt Section:** When stuck in salt circulate fresh water around; the usual amount is 5–10 m<sup>3</sup>. Depending on the type of mud in the hole a 1 m<sup>3</sup> spacer of diesel oil ahead and behind can be used. Displace the fresh water slowly around the drill collars to increase contact time (0,5 m<sup>3</sup> per min.) and stop every 1 m<sup>3</sup> pumped for five-minute soaking periods. Remember to keep maximum pull while circulating and bear in mind the need for well control.

**Pipe Freeing Agent (PFA):** If stuck in any formation where differential sticking is possible (i.e., differential pressure of formation against mud weight in the hole is high), then a pipe freeing agent, (for instance a pipelax pill), shall be spotted as quickly as possible after the string sticks. The following procedure shall be followed:

1. Clean out pill tanks.
2. Pump in diesel oil. An amount equal to twice the annular volume around the drill collars plus enough left inside the string to move the pill 0.1 m<sup>3</sup> (0.6 bbl) every half an hour over a six-hour period.
3. Add 25–50 l of PFA for each 1 m<sup>3</sup> of diesel oil.

If a weighted pill is required then add a diesel viscosifier, in a concentration of 45 sacks per 15 m<sup>3</sup> and then add barytes as required.

4. Pump the pipelax pill into the hole and displace until the 100% annular excess is around the DC's. Stop pumps and displace 100–150 ltr's every half an hour. Work pipe and torque-up continuously during the soaking.

Immediately the pipe is free start rotating and circulating.

- a. Pumping the pipelax pill, determine PC1, by taking some SCR's. If the well should flow, control can be regained by circulating out the pill using the choke to maintain PC1, for the chosen circulating rate.
- b. It is important that considerable diligence be given to mixing a weighted pipelax pill to ensure that the pill has sufficient body to hold the barytes in suspension while there is no circulation.
- c. A maximum of 24 hours after a pipelax pill is in place is an acceptable time period for working a stuck pipe. A decision on whether to continue working a stuck pipe after such a period shall be taken by the Superintendent.
- d. While the use of a pipelax pill is generally associated with water-based muds it should not be disregarded for a similar application in OBM.
- e. If the formation/mud pressure differential is high, then consider reducing the mud weight in the hole before circulating a pipelax pill.
- f. If acid is used, care must be taken especially during handling. Correct safety and protective clothing and equipment must be used.
- g. The intentional influx of formation fluids to release the stuck pipe is not allowed.

### 6.1.2 Drillpipe Failures

Drillpipe generally experiences torsion failure, although it can be pulled in two, particularly during heavy jarring. It is commonly thought that most drillpipe twists off in the handling area, i.e., three feet below the box, because of slip damage. This is not true. Slip cuts are continually being polished in the borehole and cannot become the source of corrosion failure. Inside the pipe, however, the innermost layer of drilling fluid is stationary and provides an optimum environment for the formation of corrosion pits that mature into holes in the pipe. When a hole in the pipe is found within

two or three feet of the box or pin, it is almost a sure sign of internal corrosion failure.

Stuck pipe is caused by failure to clean the hole, by keyseats, and by differential (wall) sticking. Proper mud and proper hydraulics will keep the hole clean. Keyseats may be alleviated by the use of a keyseat wiper at the top of the bottomhole assembly. Overbalance is the cause of differential sticking; running a balanced mud system will address this problem.

Drillpipe generally experiences torsion failure, although it can be pulled in two, particularly during heavy jarring. It is commonly thought that most drillpipe twists off in the handling area, i.e., three feet below the box, because of slip damage. This is not true. Slip cuts are continually being polished in the borehole and cannot become the source of corrosion failure. Inside the pipe, however, the innermost layer of drilling fluid is stationary and provides an optimum environment for the formation of corrosion pits that mature into holes in the pipe. When a hole in the pipe is found within two or three feet of the box or pin, it is almost a sure sign of internal corrosion failure.

Logging and wireline tools may become stuck in the hole at any time. Splitted wireline is very difficult to fish, as it has a natural tendency to ball up. Only relatively short sections can be recovered per fishing run. For this reason, all rope sockets should be crippled. This means that the weakest spot in the wireline needs to be at the point of attachment to the tool, so that the line may be pulled free of a stuck tool and recovered by its winch. Wireline tools should be fitted with a fishing neck so that they may be recovered with a normal fishing assembly. A sonde containing a radioactive source, an unusually expensive tool, or a tool lost in a washout or large-diameter hole should not be treated in this manner. The wireline should be left attached to the tool and recovery attempted by the cut-and-thread procedure. Although this method is more complex and takes much longer, it is more likely to recover the fish.

One of the drilling problems occurring during drilling is drillpipe failure (Figure 6.3). To complete the picture, it is better to review the types of detectable defects in drillpipe which seem to cause most of the trouble in service, which can be one of the following: (i) twist-off (excessive torque), (ii) parting (excessive tension), (iii) burst (excessive internal pressure) or collapse (external pressure), and (iv) fatigue (mechanical cyclic loads with or without corrosion).

Drillpipes are subjected to a variety of loads and environmental conditions. The drillpipe undergoes tensile stress (hook load) due to hanging weight of the string and BHA. Drillpipe section at any position in the string must have a strength, which is capable to withstand the tensile stress at that

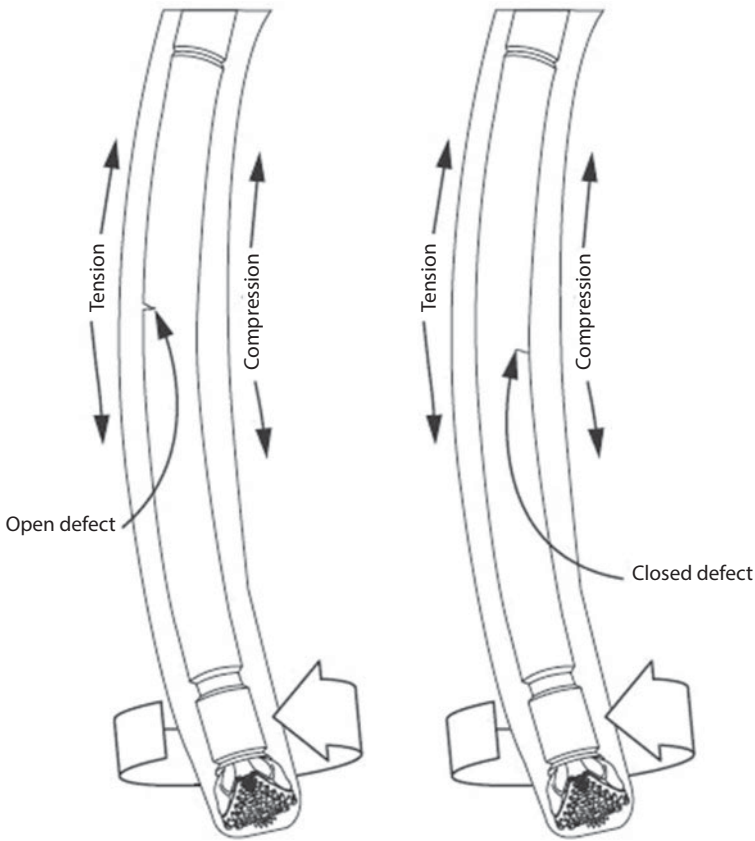

**Figure 6.3** Drilling failure (<http://petroleumsupport.com/wp-content/uploads/2013/09/Cyclic-Loading.jpg>).

section in presence of other loads: radial pressure from drilling fluid, torsional stress from rotary torque and bending stress from doglegged holes. Pipe sections at the dogleg level are usually subjected to fatigue failure due to repeated bending stress and axial tension. In order to ensure a safe drillstring, the effective stress due to combined loads for a given drilling event is calculated at this level to check that the effective stress is below the strength of the pipe selected for the level. One widely used method for such assessment is given by von Mises. According to this method, the effective stress for combined loads is called von Mises stress and is kept below the yield strength of materials.

This type of failure assessment is called static analysis as it is carried out with respect to a snapshot-drilling event without having considered

analytically the consequence of previous drilling events in which the particular pipe joint was used. Downgrading of strength properties of pipe joints that were used in some previous drilling events are provided by API as guidelines for drillstring designers. Although these guidelines are very useful for the above-mentioned strength assessment by static analysis, their use is particularly dangerous for a drillstring that rotates in wellbores with doglegs due to intentional or unintentional change in drilling direction. In such cases, the pipe section at the dogleg region undergoes cyclic tension/compression stress due to lateral bending. After a number of alternating stress cycles the pipe section may fail due to accumulative effect of fatigue damage even though the effective stress found by static analysis is significantly below the material strength. Thus, the API downgrading in strength properties of used drillpipes is not adequate to account for the failure due to cumulative effect of fatigue damage. Cumulative fatigue damage of a drillpipe is estimated using the Miner's rule (Miner, 1945). This procedure has already been used in a number of drilling events with different values of drilling parameters ever since first implemented by Lubinski in 1961 (Lubinski, 1961). Moreover, API guidelines are only available for some popular drillpipe grades such as D, E, X95, G 105 and S 135. Recently, there is a trend to use some non-API drillpipes, such as RSA-6K drillpipes. The operating data, survival history and industry accredited grading guidelines of RSA-6K drillpipes are not yet developed.

### 6.1.2.1 *Twist-off*

One of the main reasons of drillpipe failure is twist-off, which occurs when the induced shearing stress caused by high torque exceeds the pipe-material ultimate shear stress. The most wells that have twist-off are directional and horizontal wells because torque excess 80,000 Ib<sub>f</sub>-ft. Twist-off has been discussed in Chapter 2. However, in this chapter, we discuss certain elements that have not been considered in Chapter 2.

Whenever there is a non-uniformity in the drilling motion (for instance, during acceleration or slowing down of rotary table), frictional torque is inevitable on the drilling bit and BHA. Torsional vibrations (Figure 6.4) lead to irregular downhole rotations, resulting in drillstring fatigue. This is followed by eventual twist-off.

Tomax patented Anti Stick-slip Tool (AST) that provides a stable, safe drilling environment free from stick-slip vibrations produced in the process of cutting through problematic underground formations. This tool measures the mechanical specific energy (MSE) of the drilling process. A computerized downhole sensor is added to the BHA that receives

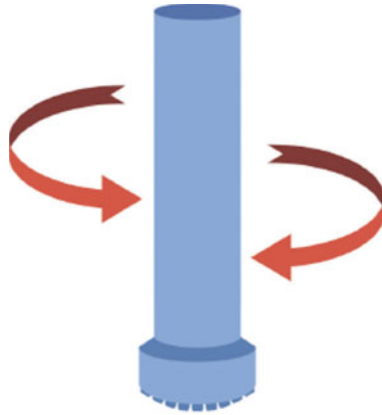

**Figure 6.4** Torsional vibration.



**Picture 6.1** HI tool.

vibration data to determine instantaneous mechanical specific energy of the downhole drilling assembly. This information, in turn, is used to suppress the stick-slip vibration, leading to faster rates of penetration (ROP).

Frank's Harmonic Isolation (HI) tool is also reported to produce effective control of vibrations. The HI Tool® is an on-bottom drilling tool, designed to reduce vibrational loads generated by drill bit dynamics (Picture 6.1)

Larsen (2014) reported that ROP is improved by 20% by using HI tools. The strength of this tool is in its ability to reduce the dynamic interactions between BHA and drill bit through a flexible gear connection, unlike the shock absorbing mechanism in AST. The HI tool is capable of decoupling the BHA and the mud harmonics from the drill bit and drillstring, thus rendering drill bit to be insensitive to local vibrations.

van Kevin Brady (2011) presented a preventative technique for dealing with twist-off problems. Based on the principle that drilling problems must have warning symptoms prior to the onset of the irreversible phenomenon, this technique collects real-time data and analyses to forecast any impending problems that can lead to twist-off. This automated case-based

reasoning (CBR) system can be continuously upgraded with newly available data and in absence of any data, can rely on drilling data acquired from other wells or even from nearby regions until local data become available. The test data lead to the formation of a novel artificial intelligence system that is dynamically 'trained' to include new data. A data library of past cases is created and continuous comparison is made with current drilling data, including well history and operator best practices. Whenever symptoms that could lead to defined problems are recognized, the most relevant case histories are retrieved and presented to the drilling team. This information is used by the team to better interpret evolving wellbore conditions. At this point also reported is the list of best practices and lessons learned for a similar set of symptoms. The team, therefore, can assess the frequency of events to correlate with eventual failure. The software was tested using data captured from an onshore well in Saudi Arabia that had experienced twist-off events. Once the cases were built, the drilling data was replayed to validate system response to known event precursors and ensure calibration. Based on this 'training', the software was applied to data acquired while drilling a gas well in the Haynesville shale of northern Louisiana where two twist-off events had occurred. The software was first 'blind tested', meaning applied directly to Louisiana wells without any adjustment. The test personnel were deliberately kept in the dark when the twist-off event would occur. As such, no daily drilling reports, mud log data or final well reports were provided. The historical Louisiana data was replayed via a WITSML data stream as if it were a live drilling operation. The system produced strong results in both twist-off events by correctly identifying them in advance of the actual occurrence. In this process, torque, stalling and stick-slip problems were identified as key parameters leading to the twist-off events, as these were considered to be the most likely indicators. Even though stick-slip was initially assumed to be a good indicator of an impending twist-off, it was found to be less important than other indicators in the cases that were captured and tested. At this point, it is not clear if this conclusion is site specific.

The Saudi Arabia well was a 17,000-ft vertical well drilled with oil-based mud, whereas the Louisiana well was an 18,000-ft horizontal well drilled with water-based mud. However, both were drilled in hard rocks, with Young's modulus exceeding 20,000 psi). There was no other correlation between the two cases. Two test cases were run that showed that precursors to drilling problems can be accurately identified far in advance of costly trouble events. This early detection enhances drilling safety and efficiency by providing ample time to resolve the situation before it becomes an actual problem.

### 6.1.2.2 *Parting and other Failures*

When the induced tensile stress exceeds the pipe-material ultimate tensile stress pipe parting failure occurs. In case of pipe stuck, pipe parting failure may arise. Parting is typical of the failures caused during over pull of a stuck pipe. As discussed in previous chapters, other failures of the drillstring include pipe sticking, pipe-parting, collapse, and burst failure. These failures frequently occur due to the similar uncertainty in stresses imposed on the downhole. The ductile fracture, brittle fracture, and fatigue are also considered within these damage mechanisms. While these are damages that occur within the drilling hole, external damages may occur from poor pipe handling. Often such damages create a weak spot in a drillpipe but elude inspectors because of the lack of any visible sign. In order to protect such eventualities, stabilizers are normally used to reduce the drillstring vibration and enhance the drilling performance. The stabilizers are also used to improve the wellbore stability and optimize the well placement for faster production in the borehole enlargement operations.

There are two common kinds of pipe sticking failures: Mechanical pipe sticking that happens due to the inadequate removal of the drilled cuttings from the annulus; and the differential-pressure pipe sticking that occurs when a portion of the drillstring becomes embedded in the mud cake (or fine solids).

### 6.1.2.3 *Collapse and Burst*

Pipe failure as a result of collapse or burst is rare; however, under extreme conditions of high mud weight and complete loss of circulation, pipe burst may occur. In order for a pipe to collapse, there has to be a weak point that acts as the trigger point. The following factors play a role.

Collapse pressure can be defined as an external pressure required causing yielding of drillpipe or casing. It can also be defined as the difference between external and internal pressure (Figure 6.5). The collapse pressure will occur if drillpipe is empty (i.e., no mud). It develops due to the difference in pressure inside and outside of drillpipe (Figure 6.6a). In normal operation, the mud column inside and outside drillpipe are both equal in height and in density (Figure 6.6b). Therefore, zero differential pressure across pipe body exists and thus no collapse happens. Normally, collapse pressure will happen during DST test.

The highest external pressure tending to collapse the drillstring will occur at the bottom when the drillstring is run empty into the hole. If a non-return valve is run, it is normally standard practice to fill up the pipe



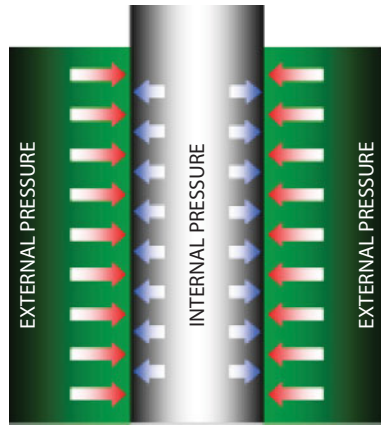

Figure 6.5 Collapse pressure (Hossain and Al-Majed, 2015).

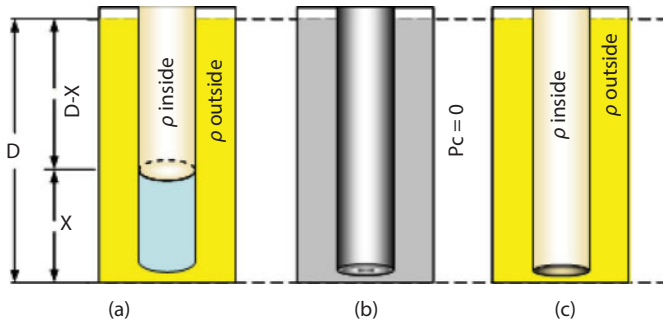

Figure 6.6 Collapse pressure at different situation for a typical drillpipe (Hossain and Al-Majed, 2015).

at regular intervals when running in. The highest anticipated external pressure on the pipe can be written as:

$$P_c = 0.052 \times \rho_f \times L_{TVD} \tag{6.2a}$$

where,

- $P_c$  = collapse pressure, psi
- $\rho_f$  = density of fluid outside the drillpipe, ppg
- $L_{TVD}$  = total true vertical depth of the well at which  $P_c$  acts, ft

Equation (6.2a) can also be expressed as:

$$P_c = \frac{L_{TVD} \rho_f}{144} \tag{6.2b}$$

where,

$$\begin{aligned} P_c &= \text{collapse pressure, psi} \\ \rho_f &= \text{density of fluid outside the drillpipe, } lb/ft^3 \\ L_{TVD} &= \text{true vertical depth at which } P_c \text{ acts, ft} \end{aligned}$$

Equation (6.2) assumes that there is no fluid inside the pipe to resist the external pressure. The collapse resistance of drillpipe is given in Table 6.1. The collapse resistance of the drillpipe is generally derated by a design factor (i.e., divide the collapse rating by 1.125). A suitable grade and weight of drillpipe must be selected whose derated collapse resistance is greater than  $P_c$ . This string must then be checked for tension.

If there are different fluids inside and outside the drillpipe, the differential collapse pressures across the drillpipe prior to opening of the DST tool (Figure 6.6a) can be obtained as:

$$\Delta p_c = 0.052 D \rho_{outside} - 0.052(D - X)\rho_{inside} \quad (6.3)$$

where,

$$\begin{aligned} D &= \text{total depth of fluid column or drillpipe, ft} \\ X &= \text{depth of the empty drillpipe, ft} \\ \rho_{inside} &= \text{density of fluid inside the drillpipe, ppg} \\ \rho_{outside} &= \text{density of fluid outside the drillpipe, ppg} \end{aligned}$$

When fluid density inside and outside drillpipe is the same (Figure 6.6b), i.e.  $\rho_{outside} = \rho_{inside} = \rho$

$$\Delta p_c = 0.052D\rho \quad (6.4)$$

When drillpipe is completely empty,  $X = 0$ , and  $\rho_{inside} = 0$ , the differential collapse pressures across the drillpipe would be the maximum collapse pressure (Figure 6.6c) and hence Eq. (6.3) can be reformed as:

$$\Delta p_{c-max} = 0.052 D \rho_{outside} \quad (6.5)$$

A safety factor in collapse can be determined by

$$SF = \frac{\text{Collapse resistance}}{\text{Collapse pressure } (\Delta p_c)} \quad (6.6)$$

Normally a safety factor of 1.125 is considered for collapse rating. In general, drillpipe is subjected to biaxial loading due to combined loading

**Table 6.1** Dimensions and Strength of API Seamless Internal Upset Drillpipe

Size of outer diameter (in.)	Weight per foot with coupling (lbf)	Internal diameter (in.)	Internal diameter at full upset (in.)	Collapse pressure*				Internal yield pressure*				Tensile strength			
				D (psi)	E (psi)	G** (psi)	S.135** (psi)	D (psi)	E (psi)	G** (psi)	S.135 (psi)	D (lbf)	E (lbf)	G** (lbf)	S.135* (lbf)
2 3/8	4.85	1.995	1.437	6,850**	11,040	13,250	16,560	7,110**	10,500	14,700	18,900	70	98	137	176
2 3/8	6.65	1.815	1.125	11,440	15,600	18,720	23,400	11,350	15,470	21,660	27,850	101	138	194	249
2.7/8	6.85	2.441	1.875	-	10,470	12,560	15,700	-	9,910	13,870	17,830	-	136	190	245
2.7/8	10.40	2.151	1.187	12,770	16,510	19,810	24,760	12,120	16,530	23,140	29,750	157	214	300	386
3 1/2	9.50	2.992	2.250	-	10,040	12,110	15,140	-	9,520	13,340	17,140	-	194	272	350
3 1/2	13.30	2.764	1.875	10,350	14,110	16,940	21,170	10,120	13,800	19,320	24,840	199	272	380	489
3 1/2	15.50	2.602	1.750	12,300	16,770	20,130	25,160	12,350	16,840	23,570	30,310	237	323	452	581
4	11.85	3.476	2.937	-	8,410	10,310	12,820	-	8,600	12,040	15,470	-	231	323	415
4	14.00	3.340	2.375	8,330	11,350	14,630	17,030	7,940	10,830	15,160	19,500	209	285	400	514
4 1/2	13.75	3.958	3.156	-	7,200	8,920	10,910	-	7,900	11,070	14,230	-	270	378	486
4 1/2	16.60	3.826	2.812	7,620	10,390	12,470	15,590	7,210	9,830	13,760	17,690	242	331	463	595
4 1/2	20.00	3.640	2.812	9,510	12,960	15,560	19,450	9,200	12,540	17,560	22,580	302	412	577	742

(Continued)

Table 6.1 Cont.

Size of outer diameter (in.)	Weight per foot with coupling (lbf)	Internal diameter (in.)	Internal diameter at full upset (in.)	Collapse pressure*				Internal yield pressure*				Tensile strength			
				D	E	G**	S.135**	D	E	G**	S.135	D	E	C**	
				(psi)	(psi)	(psi)	(psi)	(psi)	(psi)	(psi)	(psi)	(lbf)	(lbf)	(lbf)	(lbf)
5	16.25	4.408	3.750	-	6,970	8,640	10,550	-	7,770	10,880	13,960	-	328	459	591
5	19.50	4.276	3.687	7,390	10,000	12,090	15,110	6,970	9,500	13,300	17,100	290	396	554	712
5 1/2	21.90	4.778	3.812	6,610	8,440	10,350	12,870	6,320	8,610	12,060	15,500	321	437	612	787
5 1/2	24.70	4.670	3.500	7,670	10,460	12,560	15,700	7,260	9,900	13,860	17,820	365	497	696	895
5 9/16	19.00**	4.975	4.125	4,580	5,640			5,090	6,950	-	-	267	365	-	-
5 9/16	22.20**	4.859	3.812	5,480	6,740			6,090	8,300	-	-	317	432	-	-
5 9/16	25.25**	4.733	3.500	6,730	8,290			7,180	9,790	-	-	369	503	-	-
6 5/8	22.20**	6.065	5.187	3,260	4,020			4,160	5,530	-	-	307	418	-	-
6 5/8	25.20	5.965	5.000	4,010	4,810	6,160	6,430	4,790	6,540	9,150	11,770	359	489	685	881
6 5/8	31.90**	5.761	4.625	5,020	6,170			6,275	8,540	-	-	463	631	-	-

\* Collapse, internal yield and tensile strengths are minimum values with no safety factor. D.F.G.S.-135 are standard steel grades used in drillpipe.5

\*\* Not API standard; shown for information only.

of tension and collapse. Due to the biaxial loading, the drillpipe is stretched resulting in decrease in its collapse resistance.

Burst pressure develops when internal pressure is higher than that of external pressure. It can be rated as:

$$\Delta p_b = \text{Internal pressure} - \text{External pressure} \quad (6.7)$$

where,

$$\Delta p_b = \text{burst load or pressure, psi}$$

A safety factor in burst can be determined by

$$SF = \frac{\text{Burst rating}}{\text{Allowable burst}} \quad (6.8)$$

#### 6.1.2.4 Tension Load

Every drillpipe comes with a given tensile strength. The tensile strength of drillpipe is shown in Table 6.1. The tension loading can be calculated from the known weights of the drill collars and drillpipe below the point of interest. The effect of buoyancy on the drillstring weight, and therefore the tension, must also be considered. Buoyancy forces are exerted on exposed horizontal surfaces and may act upwards or downwards. These exposed surfaces occur where there is a change in cross-sectional area between different sections (Figure 6.7). The load calculation can be started at the bottom of the drillstring and working up to the top. The tension loading can be determined for each depth. This is represented graphically by the tension loading line (Figure 6.7).

If the drillpipe is to remain in tension throughout the drilling process, drill collars need to be added to the bottom of the drillstring. The buoyant weight of the drill collars must exceed the buoyant force on the drillpipe. In addition, the neutral point shown in Figure 6.7 must be within the length of the drill collars. Drill collars are required to maintain the drillstring in tension because the function of the drill collars is to provide WOB. When selecting the drillpipe, the maximum tensile loads that the string could be subjected to need to be considered. In addition to the design load calculated on the basis of the string hanging freely in the wellbore, some other safety factors and margins are generally added: i) design factor – it is generally added to the loading line calculated above (in general, multiply by 1.3) which allows for extra loads due to rapid acceleration of the pipe, ii) margin of overpull (MOP) – it is generally added to the loading line

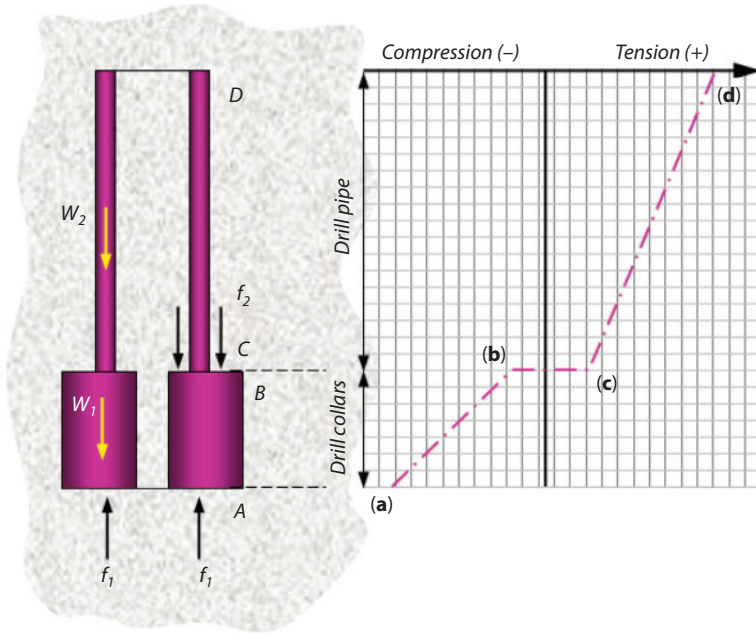

**Figure 6.7** Axial Load distributions on the Drillstring.

because this allows for the extra forces applied to the drillstring when pulling on stuck pipe.

Tabulated API properties should be considered for designing tension. The magnitude depends on mud density and steel density where submerged weight should be considered. In general steel density is considered as  $489.5 \text{ lb}_m/\text{ft}^3$  or  $65.5 \text{ lb}_m/\text{gal}$  or  $7850 \text{ kg}/\text{m}^3$ . To provide an added safety factor, only 80–90% of the yield strength tabulated is generally used for the drillpipe. Therefore, the weight and length of the drillpipe can be calculated using the load balance of the drillstring as:

$$0.9 \times \text{drillpipe yield strength} = \text{weight of DP} + \text{weight of DC} + \text{weight of HWDP} + \text{MOP} \quad (6.9)$$

where,

MOP = margin of overpull or maximum overpull on the drillstring by the drawworks,  $\text{lb}_f$

MOP is the minimum tension force above expected working load to account for any drag or stuck pipe. The typical MOP value ranges from

50,000–100,000 lbs. Maximum overpull should not exceed 80% of tensile strength of the weakest drillpipe section in the drillstring.

Mathematically, Eq. (6.9) can be written as:

$$0.9 P_d = (L_{dp} W_{dp} + L_{dc} W_{dc} + L_{Hdp} W_{Hdp}) B_f + MOP \quad (6.10)$$

Here,

- $P_d$  = drillpipe yield strength or design weight, lb<sub>f</sub>
- $L_{dp}$  = length of drillpipe, ft
- $L_{dc}$  = length of drill collar, ft
- $L_{Hdp}$  = length of heavy weight drillpipe, ft
- $W_{dp}$  = nominal weight of the drillpipe, lb<sub>f</sub>/ft
- $W_{dc}$  = nominal weight of the drill collar, lb<sub>f</sub>/ft
- $W_{Hdp}$  = nominal weight of the heavy weight drillpipe, lb<sub>f</sub>/ft
- $B_f$  = buoyancy factor, fraction =  $(1 - \rho_m / \rho_s)$
- $\rho_m$  = mud density, lb<sub>m</sub>/gal
- $\rho_s$  = density of steel, lb<sub>m</sub>/ft<sup>3</sup>

From Eq. (6.10), the total weight carried by the top joint of drillpipe is given by

$$P_a = (L_{dp} W_{dp} + L_{dc} W_{dc} + L_{Hdp} W_{Hdp}) B_f \quad (6.11a)$$

If we use safety factor, Eq. (6.11a) can be written as:

$$P_a = (L_{dp} W_{dp} + L_{dc} W_{dc} + L_{Hdp} W_{Hdp}) B_f \times SF \quad (6.11b)$$

Here,

$P_a$  = actual weight or total weight carried by the top joint, lb<sub>f</sub>

To provide an added safety factor of 90%, the theoretical yield strength can be calculated as:

$$P_t = 0.9 P_a \quad (6.12)$$

Here,

$P_t$  = theoretical yield strength, psi

If  $P_a < P_t$ , then pipe is okay for tension. In general, the difference between  $P_t$  and  $P_a$  gives the MOP.

The ratio of Eq. (6.12) and Eq. (6.11) gives the safety factor (SF) as:

$$SF = \frac{P_t}{P_a} = \frac{0.9 P_d}{(L_{dp} W_{dp} + L_{dc} W_{dc}) B_f} \quad (6.13)$$

Safety factor is normally in the range of 1.1–1.3. It is noted that SF is not applied for heavy weight drillpipe. In such case, Eq. (6.10) can be written in terms of SF as:

$$0.9 P_d = (L_{dp} W_{dp} + L_{dc} W_{dc}) B_f \times SF + L_{Hdp} W_{Hdp} B_f + MOP \quad (6.14)$$

Thus, length of the drillpipe can be found by rearranging Eq. (6.14) as:

$$L_{dp} = \frac{0.9 P_d - MOP}{SF \times W_{dp} \times B_f} - \frac{W_{dc}}{W_{dp}} L_{dc} - \frac{W_{Hdp}}{W_{dp}} \frac{L_{Hdp}}{SF} \quad (6.15a)$$

If we do not consider SF, length of the drillpipe can be found by rearranging Eq. (6.10) as:

$$L_{dp} = \frac{0.9 P_d - MOP}{W_{dp} \times B_f} - \frac{W_{dc}}{W_{dp}} L_{dc} - \frac{W_{Hdp}}{W_{dp}} L_{Hdp} \quad (6.15b)$$

If dual-grade drillpipe is used at different section of drillstring, the length of drillpipe is calculated as:

$$L_{dp2} = \frac{0.9 P_d - MOP}{SF \times W_{dp2} \times B_f} - \frac{W_{dp1}}{W_{dp2}} L_{dp1} - \frac{W_{dc}}{W_{dp2}} L_{dc} - \frac{W_{Hdp}}{W_{dp2}} \frac{L_{Hdp}}{SF} \quad (6.16)$$

Here,

$L_{dp1}$  = length of drillpipe grade 1, ft

$L_{dp2}$  = length of drillpipe grade 2, ft

$W_{dp1}$  = nominal weight of the drillpipe grade 1, lb<sub>f</sub>/ft

$W_{dp2}$  = nominal weight of the drillpipe grade 2, lb<sub>f</sub>/ft

A tapered string is designed by first considering the lightest available grade and selecting its maximum useable length as a bottom section. Successive heavy grades and their usable lengths are selected in turn.



**Example 6.1:** A drillstring needs to be designed based on the information given here. It is noted that the outer diameter of the drillpipe is 5", total vertical depth is 12,000', mud weight is 75 lb<sub>f</sub>/ft<sup>3</sup> (i.e., 10 ppg). Total MOP is 100,000 lbs and the design factor, SF = 1.3 (tension); SF = 1.125 (collapse). The bottomhole assembly consists of 20 drill collars with an outer diameter of 6.25" and an inner diameter of 2.8125" where the weight of drill collar is 83 lb<sub>f</sub>/ft and each collar is 30 ft long. In addition, you need to consider the length of slips is 12".

**Solution:**

**Given data:**

- $d_{odp}$  = outer diameter of drillpipe = 5 in
- $L_{TVD}$  = total vertical depth = 12,000 ft
- $r_m$  = mud weight = 75 lb<sub>f</sub>/ft<sup>3</sup> (10 ppg)
- MOP = margin of pull = 100,000 lbs
- $SF_T$  = design factor of safety for tension = 1.3
- $SF_c$  = design factor of safety for collapse = 1.125
- $N_{dc}$  = number of drill collar = 20
- $d_{odc}$  = outer diameter of drill collar = 6.25 in
- $d_{idc}$  = inner diameter of drill collar = 2.8125 in
- $W_{dc}$  = weight of the drill collar = 83 lb<sub>f</sub>/ft
- $L_{dc}$  = length of drill collar = 30 ft
- $L_{slips}$  = length of slips = 12 in

**Required data:**

Design the drillstring

**For Collapse loading:**

If total vertical depth is 12,000 ft, and the mud density is 10 ppg, then collapse pressure can be calculated using Eq. (6.2a) as:

$$P_C = 0.052 L_{TVD} \rho_m = 0.052 \times 12,000 \text{ ft} \times 10 \text{ ppg} = 6,240 \text{ psi}$$

If we use 75 lb<sub>f</sub>/ft<sup>3</sup> mud, collapse pressure can be calculated using Eq. (7.1b) as:

$$P_C = \frac{L_{TVD} \rho_m}{144} = \frac{(12,000 \text{ ft} \times 75 \text{ lb}_f/\text{ft}^3)}{(144 \text{ in}^2/\text{ft}^2)} = 6,250 \text{ psi}$$

Applying SF for collapse,  $P_C = 6,250 \text{ psi} \times 1,125 = 7,031 \text{ psi}$

Now from Table 6.1, choose 19.50 lb<sub>f</sub>/ft for 5" and we select Grade D for which ID = 4.276".

**For Tension loading:**

$$BF = 1 - \frac{\rho_f}{\rho_s} = 1 - \frac{75 \text{ lb}_f/\text{ft}^3}{490 \text{ lb}_f/\text{ft}^3} = 0.847$$

Now if we apply Eq. (6.11b) to calculate actual weight or total weight carried by the top joint, it becomes as:

$$\begin{aligned} P_a &= MOP + (L_{dp} W_{dp} + L_{dc} W_{dc}) \times BF \times SF_T \\ &= 100,000 + [(12,000 - 20 \times 30) \times 19.5 + (20 \times 30) \times 83] \times 0.847 \times 1.3 \\ &= 400,000 \text{ lb}_f \end{aligned}$$

From Table 7.4, for 5" and 19.5 lb<sub>f</sub>/ft drillpipe,

$$\begin{aligned} P_t &= 396,000 \text{ lb}_f \text{ for Grade E and} \\ &= 290,000 \text{ lb}_f \text{ for Grade D} \end{aligned}$$

**Decision:** We need to select Grade E instead of Grade D because of huge difference of tensile strength. However as long as actual weight is greater than the theoretical yield strength (i.e.  $P > P_t$ ), therefore the selected design of Grade **E is not OK** and needs to be verified again.

As the chosen grade is not OK, let us choose the next grade, which is 5½" outer diameters. For this grade, let us choose the weight of the drillpipe as 21.90 lb<sub>f</sub>/ft and grade E for which the tensile yield strength is 437,000 lb<sub>f</sub>. Now, apply the chosen grade for the entire pipe.

**For Tension and Compression loading (Figure 6.8):**

At 12,000 ft i.e., the bottom of DC:

$$P_{dC\_bottom} = 0.052 L_{TVD} \rho_m = 0.052 \times 12,000 \text{ ft} \times 10 \text{ ppg} = 6,240 \text{ psi}$$

Cross sectional area of DC:

Referring to Figure 6.8,

$$A_{dC\_bottom} = \frac{\pi}{4} (d_{Od}^2 - d_{id}^2) = \frac{\pi}{4} (6.25^2 - 2.812^2) = 24.47 \text{ in}^2$$

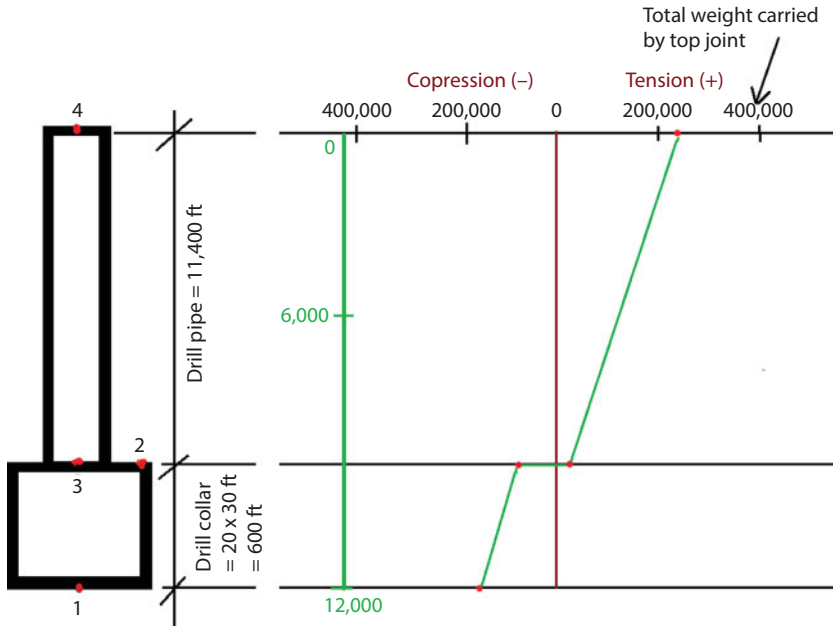

Figure 6.8 Axial Load distributions on the drillstring for Example 6.1.

$$F_{1\_bottom} = P_{dC\_bottom} \times A_{dC\_bottom} = 6,240 \times 24.47 = 152,692.8 \text{ lb}_s$$

$$W_{1\_dc} = L_{dc} \times \rho_{dc} = (20 \times 30) \times 83 = 49,800 \text{ lb}_s$$

So, tension at the bottom of the collar at point 1 =  $-F_{1\_bottom} = -152,692.8 \text{ lb}_s$   
(Tension)

At 11,400 ft i.e. the top of DC:

$$\begin{aligned} A_{dC\_top} &= \frac{\pi}{4} [(d_{Od}^2 - d_{id}^2)_{outer} + (d_{Od}^2 - d_{id}^2)_{inner}] \\ &= \frac{\pi}{4} [(6.25^2 - 5.0^2) + (4.276^2 - 2.8125^2)] = 19.19 \text{ in}^2 \end{aligned}$$

$$P_{dC\_top} = 0.052 L_{TVDD} \rho_m = 0.052 \times 11,400 \text{ ft} \times 10 \text{ ppg} = 5,928 \text{ psi}$$

$$F_{2\_top} = P_{dC\_top} \times A_{dC\_top} = 5,928 \times 19.19 = 113,758 \text{ lb}_s$$

$$W_{2\_dc} = L_{dp} \times \rho_{dp} = (11,400 \text{ ft} \times 19.5) = 222,300 \text{ lb}_s$$

So, tension at the top of the collar at point 2

$$\begin{aligned} &= -F_{1\_bottom} + W_{1\_dc} = (-152,692.8 + 49,800) \text{ lb}_s \\ &= -102,892.8 \text{ lb}_s \text{ (Compression)} \end{aligned}$$

At 11,400 ft i.e., the bottom of the DP (Point 3):

$$A_{dp\_bottom} = \frac{\pi}{4} [(d_{Od}^2 - d_{id}^2)_{outer} + (d_{Od}^2 - d_{id}^2)_{inner}] = 19.19 \text{ in}^2$$

$$P_{dp\_bottom} = 0.052 L_{TVD} \rho_m = 0.052 \times 11,400 \text{ ft} \times 10 \text{ ppg} = 5,928 \text{ psi}$$

$$F_{3\_bottom} = P_{dp\_bottom} \times A_{dp\_bottom} = 5,928 \times 19.119 = 113,758.0 \text{ lb}_s$$

$$W_{3\_dp} = L_{dp} \times \rho_{dp} = (11,400 \text{ ft} \times 19.5) = 222,300 \text{ lb}_s$$

So, tension at the bottom of the drillpipe at point 3

$$\begin{aligned} &= -T_{2\_dp-dc} + F_{3\_bottom} \\ &= (-102,829.8 + 113,578) \text{ lb}_s \\ &= 10,865.2 \text{ lb}_s \text{ (Tension)} \end{aligned}$$

At the top of the DP (Point 4):

$$W_{4\_dp} = L_{dp} \times \rho_{dp} = (11,400 \text{ ft} \times 19.5) = 222,300 \text{ lb}_s$$

$$\begin{aligned} F_{4\_top} &= \text{tension at the bottom of the drillpipe at point 3} \\ &= T_3 = 10,865.2 \text{ lb}_s \end{aligned}$$

So, tension at the top of the drillpipe at point 4 =  $W_{4\_dp} + F_{4\_top}$

$$= 222,300 \text{ lb}_s + 10,865.2 \text{ lb}_s = 233,165.2 \text{ lb}_s \text{ (Tension)}$$

### Maximum allowable load:

If we assume that 85% of theoretical load can be allowed to carry by the drillstring, then the maximum allowable load is:

$$W_{4\_dp} = 0.85 \times P_t = 0.85 \times 396,000 \text{ lb}_s = 336,750 \text{ lb}_s$$

The total weight carried by the top joint, 400,000 lb<sub>s</sub> and as the maximum allowable load is 335,750 lbs, therefore a different size of the drillpipe need to be selected for at least 1,200 ft (Figure 6.9). From Table 6.1, for 5.5” and 21.90 lb<sub>f</sub>/ft drillpipe, P<sub>t</sub> = 437,000 lb<sub>f</sub> for Grade E. this grade can be selected up to 1,200 ft.

**Decision:**

We may choose the next grade for only the first 1,200’

0 – 1,200 ft : Grade E, 21.90 lb<sub>f</sub>/ft

200 – 12,000 ft : Grade E, 19.5 lb<sub>f</sub>/ft

**Check the New Grade:**

Now if we apply again Eq. (6.11b) to calculate actual weight or total weight carried by the top joint, it becomes as:

$$P_a = MOP + (L_{dp} W_{dp} + L_{dc} W_{dc}) \times BF \times SF_T$$

$$P_a = 100,000 + [1,200 \times 21.5 + (10,800 - 20 \times 30) \times 19.5 + (20 \times 30) \times 83] \times 0.847 \times 1.3 = 402,251.95 \text{ lb}_f$$

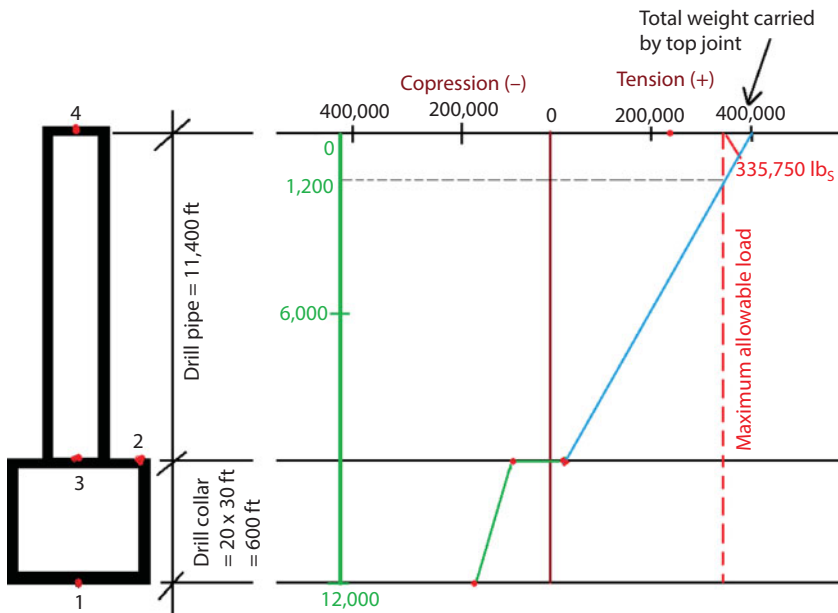

**Figure 6.9** Axial Load and maximum load distributions on the Drillstring for Example 6.1.

Table 6.1 shows,  $P_t = 437,000 \text{ lb}_f/\text{ft}$ , and finally it shows that  $P_a < P_t$ . Therefore, the design is ok and this is the final design decision.

### 6.1.2.5 Fatigue

Fatigue is the most common and costly type of failure in oil/gas drilling operations. Typically, fatigue is the result of sustained stress, often with periodic motion. Such sustained stress leads to development of microcracks. With continued increase and decrease of stress, these microcracks combine and form macrocracks that eventually reduce the strength of the concerned material. The combined action of cyclic stresses and corrosion can shorten the life expectancy of a drillpipe by thousandfolds. Although a lot of work and research have been done on fatigue still it is the least understood. It is understood that preventing or controlling drillpipe failure from happening cannot be eliminated totally. However, here are some measures that can minimize or mitigate the failure:

1. Minimizing induced cyclic stresses and insuring a noncorrosive environment during the drilling operations can mitigate fatigue failure. The use of stabilizers can be helpful.
2. Cyclic stresses can be minimized by controlling dogleg severity and drillstring vibrations. Tools that can reduce have been discussed in previous sections and will be discussed again under the section on vibration control.
3. Corrosion can be mitigated by corrosive scavengers and controlling the mud pH in the presence of  $\text{H}_2\text{S}$ .

#### 6.1.2.5.1 Fatigue Testing of Drillpipe

Fatigue damage occurs when a drillpipe is subjected to sufficiently high alternating stresses, such as those created when the drillpipe rotates in the curve of a wellbore. Drillpipe fatigue failure has been a serious concern in the oil industry ever since sections of drillpipe were first joined to permit drilling at depths greater than one length of drillpipe. This problem was addressed by imposing dogleg severity limits based on test results published in the early 1950s. These tests were satisfactory for their intended use (i.e., testing of tool-joint welds). However, these tests were not performed in a corrosive environment or under axial tension, two factors considered important in current API guidelines. During these tests, the effect of corrosion was addressed by use of simplifying assumptions with respect to the decrease in fatigue strength in a corrosive environment. The effect of mean stress was dealt with by use of a modified Goodman equation for the

endurance limit and a standard Goodman equation for stresses above the endurance limit.

Tsukano *et al.* (1988) presented a detailed description, highlighting the effect of upset/pipe-body transition-zone geometry in their investigation of the internal-upset drillpipe geometry using finite-element analysis and tests. They sought a combination of taper length and radius of run out that would cause fatigue failure in the drillpipe body rather than in the pipe body/upset transition zone. To verify the results of the finite-element investigation, full-sized specimens were tested in four-point rotary-bending arrangements in air at a high stress range (location of crack initiation was the only factor investigated). Recommendations were made for suitable internal-upset geometry to prevent drillpipe failure in the upset region.

In 1988, Dale presented the results of a test program on API drillpipe steels conducted to determine the influence of drilling fluid environment on fatigue-crack growth rate. Although the program mainly studied fatigue in a full-sized drill collar, it also included a series of fatigue tests on coupon specimens in drilling muds of various composition. The tests, conducted at a S-Hz frequency, showed no significant effect of drilling mud corrosivity on crack growth rate.

Helbig and Vogt (1987) presented the results of a study on drillpipe fatigue life in a corrosive environment that investigated the effect of heat treatment on Grades D, E, and S-135 drillpipe. Full-sized sections of drillpipe bodies were fatigue tested in two corrosive environments: tap water and 20% NaCl solution. The test results did not indicate a significant difference between normalized and quenched-and-tempered specimens or between the two test environments. From their tests on coupon specimens, Helbig and Vogt (1987) demonstrated that the speed of testing is influential when tests are conducted in a corrosive environment. Fatigue life was reduced significantly when the testing frequency was decreased from 1,000 to 100 rev/min; the amount of reduction depended on the stress range at which the tests were conducted. All the tests of Helbig and Vogt (1987) on full-sized drillpipe were performed in a corrosive environment. Consequently, fatigue life of full-sized drillpipe in air and in a corrosive environment cannot be compared with their data. No experimental investigation to date has specifically addressed the problem of the effect of mean stress on the fatigue life of full-sized drillpipe operating in air or in a corrosive environment. As the search for petroleum moves into more-hostile environments that require drilling to greater depths and in more-corrosive media, the oil industry is again confronted with the problem of drillpipe fatigue. One failure is estimated to occur for every 6,500 ft [1980 m] drilled, including drillpipe separations and washouts. Most drillpipe failures

generally are agreed to result from metal fatigue. Recent publications show that drillpipe failure is still a serious concern of drilling contractors. More research is therefore required to determine the effect of such parameters as mean stress and corrosion on drillpipe fatigue life.

Grondin and Kulak (1994) conducted a comprehensive study using 29 tests in air and 27 tests in saline environment. Their study identified stress as well as the range of stress to be important in governing drillpipe fatigue life. Of the 29 specimens tested in air 13 failed because of fatigue developed at grinding marks. Also, 13 out of 27 specimens in saline environment failed because of fatigue due to grinding marks. X-ray diffraction tests confirmed that the fatigue is due to erosion of compressive strength. They recommended that grinding be kept at minimum and heat treatment be imparted in order to restore damages during the inspection stage. They also recommended that drillpipe be replaced as soon as a washout is detected because twist-off is likely to occur shortly after the washout.

### 6.1.3 Problems Related to Catches

The strongest type of catch is the screw-in connection and Figure 6.10 shows the internal catches. This simply is the procedure of screwing back in an upward-looking box with a pin of the same thread, or vice versa. This is the catch used after free drillstring is backed off during stuck pipe recovery. The second strongest catch is the outside grab. Overshots and

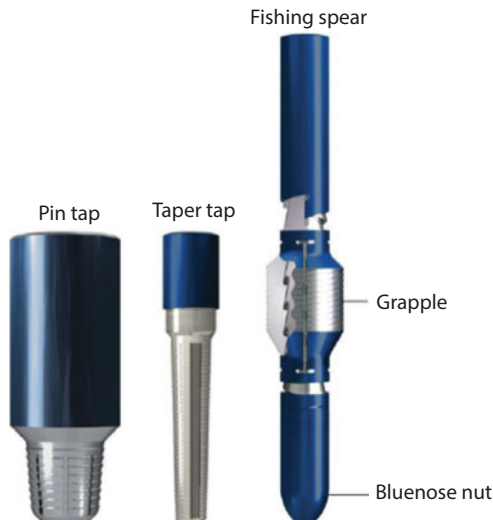

Figure 6.10 Internal catches.



die collars are tools used in this technique. The third strongest catch is the inside catch; spears and taper taps are inside catch devices. The outside catch is stronger than the inside catch for the same reason that upset tubing has a greater setting depth than non-upset tubing of the same size, i.e., greater thread or slip surface area. When the annulus decreases to a point beyond which an outside catch tool would have insufficient cross sectional material to do the job, an inside catch must be used. The fourth type of grab is the swallow. This catch is weak, but it is often very useful. The junk basket and poor boy basket have done good service when applied correctly.

### 6.1.4 Fishing Operation

The loss of a drilling tool down a well bore has caused trouble practically since the first commercial well in America. From the very first well all the way up to modern drilling, fishing remains an integral part of drilling operations. Retrieving a lost drillpipe or any component of the drillstring is a challenging engineering task.

#### 6.1.4.1 *Stuck Pipe Fishing*

A fish is a part of the drillstring (i.e., tubing, sucker rods, wire, rope or cable) that separates from the upper remaining portion of the drillstring while the drillstring is in the well. Fishing is defined as the process of retrieving a stuck pipe which is left in hole after back-off or twist-off operations. This can result from the drillstring failing mechanically, or from the lower portion of the drillstring becoming stuck or otherwise becoming disconnected from drillstring upper portion. Such an event will activate an operation to free and retrieve the lower portion (or fish) from the well with a strengthened specialized string. Fishing involves running a set of equipment to the top of the fish, engaging it and then retrieving it. There are many techniques and procedures for fishing, and the drilling engineer must determine the appropriate method for retrieving the lost or stuck item, usually referred to as the fish. For example, wireline fishing is considerably different from fishing with drillpipe. The nature of the fish itself may dictate the procedure. A fish may be free or stuck. If the fish is stuck, jarring or washover operations may be needed.

#### 6.1.4.2 *Fishing for a "Twist-off"*

Examine the bottom of the recovered drillstring and determine as far as possible the condition of the top of the fish. Dress the appropriate circulating, releasing overshot with the mill guide, slips or grapples, and pack-off

rubber necessary to catch the fish. Use a cut lip guide. Prepare a fishing assembly with jars and bumper sub and run it in to within one joint of the fish. Circulate and condition the hole; if not mudded up do so at this time. Never attempt to catch the fish without mud in the hole. Going back to bottom without mudding up is a risk best taken by young men working in boom times. After the hole is in good shape, lower the drillstring near the top of the fish and circulate for a few minutes only. Stop circulating and attempt to engage the fish. Go down until some weight is taken off the blocks, then pick up slightly. Turn the pipe a little so that the cut lip of the overshot skirt either kicks the overshot over the fish or off to the side. Take more weight off the blocks to seat the slips or grapple, then pick up to see if the fish is caught. If not, repeat the procedure, being very gentle in order not to rough up the top of the fish. It may be necessary to mill the burrs off the top of the fish so that the overshot will slip on. This is accomplished with the mill guide with which the tool was dressed.

### **6.1.5 Failures Caused by Downhole Friction Heating**

The last few years have seen a dramatic increase in extreme friction heating induced failures of oilfield drillstring components. Although surface friction heating damage in the form of heat check cracking has been known to occur since the late 1940s, extreme friction heating failures due to the steel being heated above its critical temperature of 1,300–1,500 °F are now becoming more frequent.

Drillstring failures caused by friction heating of bottomhole assembly (BHA) components and drillpipe have increased dramatically over the last several years. Although drilling engineers are familiar with heat checking caused by downhole heating due to borehole friction, catastrophic overheating failures were rarely experienced prior to the last several years. The consequences of severe downhole heating can be dire often resulting axial separation of the drillstring creating potential well control safety issues, costly fishing jobs and other remedial efforts.

In one failure mode, the drillpipe is heated above a critical transformation temperature accompanied by a rapid decrease in tensile strength. Subsequently, the component fails under a tension loading, well below the rated strength of the drillstring. Recently, another failure mode of heavy-weight drillpipe has been documented on three different wells where the pipe parted in a purely brittle mode. These fractures occurred as a direct consequence of the steel being heated above its critical temperature, followed by rapid cooling (quenching) by the drilling fluids resulting in a very brittle, low toughness steel. The fracture surfaces that occur from this

failure type often cause confusion during failure investigation due to the presence of flat fracture surfaces which are rarely seen in drillpipe and BHA components. Due to increasingly harsh drilling conditions it is likely these types of failures will become more common.

#### 6.1.5.1 Heat Check Cracking

Prior to the introduction of top drive drilling operations, heating damage to drillstring components was generally limited to heat checking of tool joint surfaces. Heat checking or heat check cracking is a friction heating phenomenon observable by the presence of multiple, fine shallow depth cracks that traverse in the direction perpendicular to the relative rotation direction of the contact surfaces. Figure 6.11 is an example of heat check cracking near the shoulder of a box tool joint. The large cracks are being formed from smaller cracks which bridged together. (Lucien Hehn *et al.*, 2007). The direction of the cracks in Figure 6.11 is along the pipe axis direction and is perpendicular to the direction of rotation. The best method of detecting these fine cracks is wet magnetic fluorescent particle (wet mag) inspection; although magnetic powder is more easily available in the field it does not offer the high resolution afforded by wet mag which will detect virtually all small cracks of this type. Altermann *et al.*, (1992) found that heat check cracks could be produced in the laboratory only when alternate

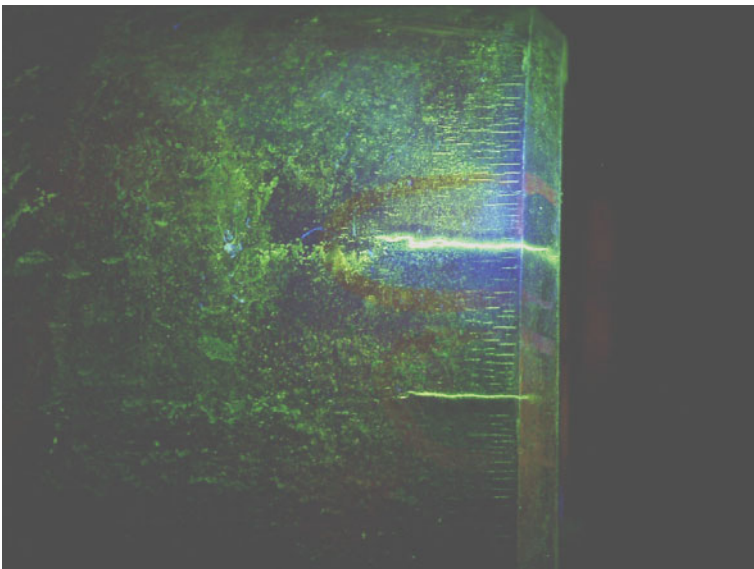

**Figure 6.11** Example of heat check cracking near the primary shoulder of a box tool joint.

heating and quenching of the friction heated contact surfaces occurred at every rotation cycle. This would imply that the driving mechanism for the generation of heat check cracking is heating to above the critical temperature followed by quenching in rapid cycles. Thus, heat check cracking has also been referred to as *thermal fatigue*.

Heat checking can occur anywhere on the drill stem surface but usually appears on the box tool joint. Although heat check cracks are usually limited from a few to several thousandths of an inch in depth, they can reach a depth of 0.25 in. or more. If a heat checked tool joint is repaired by turning down the OD, it should be reinspected afterwards since there is no way of knowing beforehand the depth of all the cracks. If joints containing these small shallow cracks are left in the string they can bridge together to form much larger cracks that can then grow to failure under assistance by stress corrosion cracking and corrosion fatigue.

#### 6.1.5.2 Ductile and Brittle Fractures

Metallurgical analysis of a failure is not possible in the field; however, there are general features of the fracture face that are indicative of brittle type failure. Brittle failure is caused by a conversion of the high toughness steel into a low toughness brittle form created by heating above temperature A. Properly manufactured drill stem products that have not been altered by downhole heating or other operating conditions will generally fail in ductile manner if overloaded, and this occurs at a predictable stress level. Ductile overload occurs from dislocation motion which can only be driven by shear stresses. The shear stress has a maximum at  $45^\circ$  to the direction of the applied stress (Figure 6.12a). Hence, the fracture face of a ductile

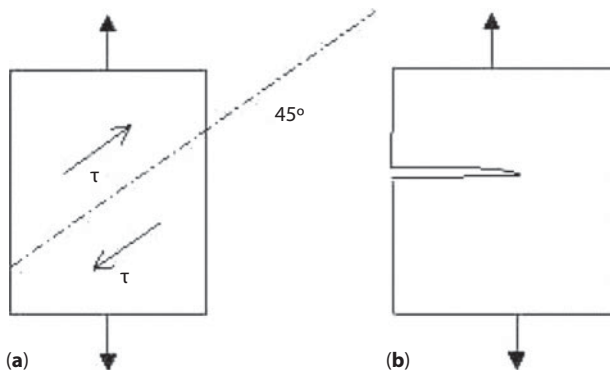

**Figure 6.12** (a) Ductile fracture occurring at maximum shear stress,  $\tau$  at  $45^\circ$  (b) Brittle fracture which requires crack propagation from stresses at  $90^\circ$  (Lucien Hehn *et al.*, 2007).

overload failure always has surface features which take an orientation of 45° to the applied load. In addition, ductile overload fracture faces show a fibrous texture from the shearing involved in the failure. In a brittle material, dislocations can move only with great difficulty, hence fracture occurs through the propagation and growth of a sharp crack. Sharp cracks are driven by loading in a direction 90° to the plane of the crack (Figure 6.12b). Hence, brittle fracture happens in a fundamentally different way than ductile overload. Any brittle type failure should be suspect as either a manufacturing error or a result of a downhole heating. When additional evidence of downhole heating such as friction wear and bluing of steel are also present, then the brittle fracture must be due to heating downhole and not a manufacturing process related defect.

The industry's continued advancement to drill deeper and further at increasing rotational speeds has led to an increasing trend of drill stem friction heating failures. One of the leading contributors to this increasing trend is the predominate use of top drives over kelly drive systems. Other contributing factors are the increasing frequency of directional drilling such as ERD, the use of rotary steerable systems (RSS) and the increasing total vertical depth (TVD) of current wells. Friction heating failures involving unusual brittle fractures occur from the steel reaching either the  $A_1$  or  $A_3$  temperatures downhole. Characteristic features of these types of failures were given as well as methods to minimize their occurrence.

### 6.1.5.3 *Mathematical Models for Drillstring Failure*

Designing the mathematical algorithm and a computer program using a Visual Basic for predicting and preventing drillstring failure before and while drilling, by considering the causes of drillstring failure that may occur in different situations was developed by Shokir (2004). The validity of this program is successfully approved by its application on some failure cases. Therefore, it could be successfully applied in other cases, and easier recognized if the drillstring is close to fail and hence an immediate action is to be taken to improve the drilling parameters to prevent the drillstring failure.

Maximum dogleg severity can be obtained from the directional survey sheet of the well Determine the permissible dogleg severity by using the following Equation:

$$k = \frac{432000\sigma_b \tanh L\sqrt{T_n/EI}}{\pi EDL\sqrt{T_n/EI}} \quad (6.17)$$

The maximum permissible bending stress ( $\sigma_b$ ) is calculated from the buoyed tensile stress ( $\sigma_t$ ) for grades E & S pipe by using the following Equations

$$\sigma_{bE} = 19500 - \sigma_t \left( \frac{10}{67} \right) - \left[ (\sigma_t - 33000)^2 \left( \frac{0.6}{(670)^2} \right) \right] \quad (6.18)$$

$$\sigma_{bs} = 20000 \left( 1 - \frac{\sigma_t}{145000} \right) \quad (6.19)$$

where:

- $K$  = maximum permissible dogleg severity, degree/100 ft
- $E$  = young's modulus, psi =  $30 \times 10^6$
- $D$  = drillpipe outside diameter, inch
- $L$  = half the distance between the tool joints, inch
- $I$  = drillpipe moment of inertia =  $(\pi/64)(D^4 - d^4)$ , inch
- $D$  = drillpipe inside diameter, inch
- $\sigma_{bE}$  = maximum permissible bending stress for grade E pipe, psi
- $\sigma_t$  = buoyed tensile stress, psi =  $T_n / A$
- $T_n$  = tension load below the dogleg, lb
- $A$  = cross-sectional area of drillpipe,  $inch^2$
- $\sigma_{bs}$  = maximum permissible bending stress for grade S pipe, psi

If the resultant well dogleg is greater than the permissible dogleg, failure may occur. Else, check the next item.

### Operating Torque

Determine the twist angle for drillpipe, heavy weight drillpipe, and drill collar by using the following Equation:

$$\frac{\theta}{L} = \frac{T}{JG} \quad (6.20)$$

where:

- $\theta/L$ : angle of twist (radians/inch)
- $L$ : length of drillstring
- $T$ : torque, ft-lb
- $G$ : modulus of rigidity, psi =  $12 \times 10^6$
- $J$ : polar moment of inertia,  $inch^4$

J can be calculated for drillpipe and drill collar from the following Equations:

$$J = \frac{J_{Body}J_{Joint}}{[0.95J_{Joint} + 0.05J_{Body}]} \quad (6.21)$$

For drillpipe:

$$J_{Body} = \pi/32[(OD_{Body})^4 - (ID_{Body})^4] \quad (6.22)$$

$$J_{Joint} = \pi/32[(OD_{Joint})^4 - (ID_{Joint})^4] \quad (6.23)$$

For drill collar:

$$J = \pi/32[(OD_{Body})^4 - (ID_{Joint})^4] \quad (6.24)$$

If the operating torque exceeds the make-up torque, the angle of twist will be greater than the calculated angle of twist and hence failure may occur. Else, check the next item.

### Bottom Hole Assembly Length

By knowing the designed maximum weight on bit from the bit specifications, using HWDP as transition stiffness between drill collar and drillpipe is recommended. Determine the length of the heavy weight drillpipe (HWDP) as following:

$$L_{HWDP} = \left[ \frac{(WOP)(DF_{BHA})}{(K_B)(\cos \theta)} - (L_{DC}W_{DC}) \right] \frac{1}{W_{HWDP}} \quad (6.25)$$

where:

- $L_{HWDP}$  = minimum length of HWDP section, ft
- $WOP$  = maximum weight on bit, lb.
- $DF_{BHA}$  = design factor for excess BHA weight = 1.15.
- $L_{DC}$  = minimum length of drill collar section, ft.
- $W_{DC}$  = air weight of drill collar, lb/ft.
- $W_{HWDP}$  = air weight of HWDP, lb/ft.
- $K_B$  = buoyancy factor.
- $\theta$  = maximum hole angle at BHA, degree.

If the designed length of the heavy weight drillpipe is less than the calculated HWDP, the neutral point will be in the drillpipe and hence failure may occur, so, adjust the length of the HWDP to bring the neutral point below the drillpipe. Else, check the next item.

### 6.1.6 Vibration Induced Anomalies

Most petroleum wells experience shock and vibration. The degree of vibration is much higher in offshore applications. Because vibrations lead to fatigue, they are identified as one of the most significant factors that affect ROP and overall drilling efficiency. Fast drilling may instigate the generation of downhole vibrations, leading to premature failure of downhole components. In general, vibrations lead to wasted energy input. When vibrations are generated they will consume energy, and thereby prohibit efficient transfer of energy to the bit.

Vibrations are unavoidable since drilling is the destructive process of cutting rock either by chipping or by crushing. Because the drilling takes place within a massive solid rock system, it must involve vibrations. However, the degree of vibrations differs depending on the complexity of the terrain being drilled. Particularly intense vibrations take place in the poor drillability formations, deep well and ultra-deep well with the long drillstring, the deep water to ultra-deep water with vortex-induced vibration (VIV) of slender marine structures, coal and shale formation with borehole instability, irregular borehole diameter, and well trajectory increasing the level of drillstring vibration and shock (V&S). Drillstring V&S cause serious failures of drilling tools and while-drilling-monitoring equipment such as drillpipe, drill collar, logging while drilling (LWD), measuring while drilling (MWD), pressure and temperature while drilling, engineering parameters while drilling (EPWD), pressure while drilling (PWD), and drill bits (Dong *et al.*, 2016). Picture 6.2 shows typical drilling tools failure due to V&S in different drillstring components. Dong *et al.* (2016) reports that nonproductive time (NPT) caused by the drillstring V&S account for 25% of total NPT every year, which seriously restrict the development of automatic drilling and the ROP. This is illustrated in Figure 6.13.

Downhole vibrations can be categorized into three primary classifications, axial, torsional and lateral/transverse. These three vibration modes have different vibrational patterns and each is generated by unique sources and leads to a unique set of problems. Combinations and interactions of these motions can exist, increasing the complexity of the vibration motions. It is also possible that some sort of synchronization may develop, leading to the onset of microfissures. Under sustained vibrations, catastrophic consequences can arise.





**Picture 6.2** Damages caused by V&S in different drillstring components (Dong *et al.*, 2016).

### 6.1.6.1 Axial Vibrations

Axial vibrations are caused by the movement of the drillstring and may induce bit bounce. Bit bounce is seen when large weight on bit (WOB) fluctuations causes the bit to repeatedly lift off bottom, in vertical direction along the drillstring, and then drop and impact the formation (Aadnøy *et al.*, 2009). Axial vibrations are detectable by the driller at shallow depths, as the vibrations travel to the surface through the drillstring. This mode of vibration is considered less aggressive than the other modes and the recorded axial accelerations are usually significantly lower. It's because

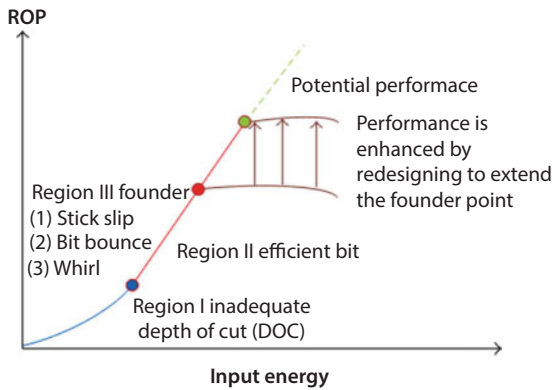

**Figure 6.13** The relationship of drilling parameters, ROP, and input energy (Dong *et al.*, 2016).

drilling process itself is self-correcting during the vertical segment of the well. However, the severity of axial vibrations is strongly affected by the interaction between the bit and the formation. For instance, Tricone bits have a tendency of creating bit bounce, particularly in hard formations, and roller cone (RC) bits in general are believed to generate high axial vibration level. Tricone bits consist of three cones and are most often used when drilling the top sections. When the three cones move up and down together a three-lobe pattern is generated, thus forming chaotic patterns on the bottom. The shape of the original pattern can be compared to a sinusoidal curve. This chaotic patterns emerge due to combination of various periodic signals. An overall axial vibration mode emerges when the cones interact with the underlying formation.

Real-time remedy of axial vibrations is to adjust the RPM and WOB, for instance, by increasing the WOB and reducing the RPM. This changes the drillstring energy. If this does not work, it is recommended to stop drilling to allow the vibrations to cease and thereafter start drilling with different parameters (Schlumberger, 2010). This must be done in correlation with the ROP, as WOB and RPM are the most highlighted parameters affecting the drilling speed. In extremely hard formations, it can be difficult to completely eradicate axial vibrations, as a minimum ROP is required and specified by the operator. A less aggressive bit should be considered as a possible last-ditch remedy.

### 6.1.6.2 Torsional Vibrations

Torsional vibrations are twisting motions in the drillstring. These vibrations are mainly caused by stick-slip. The vibrations are generated when

the bit and drillstring is periodically accelerated or decelerated, due to frictional torque on the bit and BHA. Torsional vibrations lead to irregular downhole rotations. Non-uniform rotation is developed when the bit becomes temporary stationary, causing the string to periodically torque up and then spin free. Every time such motion occurs, a permanent mark on the drillstring is made. The severity of stick-slip will affect how long the bit stays stationary and consequently the rotational acceleration speed when the bit breaks free. The downhole RPM can become several times larger than the RPM applied at surface. Torsional vibrations are highly damaging and are identified as one of the main causes of drillstring fatigue and bit wear. In severe cases, over-torqued connections and drillstring twist-offs have been observed. When this phenomenon occurs, it consumes part of the energy originally dedicated to the ROP and it has been documented that stick-slip can lead to the ROP being decreased by 30–40% (Aadnøy *et al.*, 2009).

Stick-slip can either be caused by the rock-bit interaction or by the interaction between the drillstring and the borehole wall. The vibration mode is typically seen in environments such as high angle wells with long laterals and deep wells. Other factors, such as aggressive polycrystalline diamond compact (PDC) bits with high WOB, and hard formations or salt also seem to instigate the generation of stick-slip.

Torsional vibrations are damped by the torsional stiffness of the drillstring and by the friction against the wellbore wall. The stiffness in torsional direction is not as significant as the stiffness in the length direction and hence the dampening is less pronounced than for axial vibrations. Due to the elasticity of the drillstring, the rotations often become irregular. A stiffer drillstring could potentially dampen the stick-slip indices. The vibration mode is observed at surface as large variations in torque values. Even in deviated wells, torsional vibrations can be detected by surface measurements and reduced by the driller (Schlumberger, 2010).

The severity of torsional vibrations is dependent on both RPM and WOB, as for axial vibrations. The ideal RPM varies according to the conditions in the well. With higher WOB the possibility of stick-slip will increase, as the cutters will dig deeper into the formation and thereby increase the torque and lateral forces on the BHA. During drilling, the stick-slip level can be reduced by lowering the WOB and increasing the RPM.

As discussed in previous sections, a number of tools can be added to the BHA that would alleviate torsional vibration by acting as a detuner or vibration damper. The detuner effect changes the stiffness of the drillstring and hence the natural frequency, thus separating the excitation frequency from the component's natural frequency, whereas the damper effect absorbs

the vibration within the drillstring, reducing the effects of the torsional vibration.

### 6.1.6.3 *Lateral/transverse Vibrations*

Lateral vibrations are seen as side-to-side motion in transverse direction relative to the string, as shown in Figure 6.14.

This mode is best described as a whirling motion. This motion is limited to the scenarios for which enough lateral movement in the BHA to bend out and touch the borehole wall. In its severest form, lateral/transverse vibrations can trigger both axial and torsional vibrations, a phenomenon known as mode coupling. This is the process that can create small-scale resonance from perturbations in different directions. As such, this is considered to be the most destructive mode in a drilling operation. Severe damage to the BHA can occur, leading to problems, such as, over gauge holes, damaged equipment, lack of well direction control and drillstring fatigue.

Lateral/transverse vibrations are not easily detected at the surface, as the vibrations tend to dampen out before its existence is 'felt' at the surface. As such, these vibrations are difficult to detect, thus eluding preventative measures.

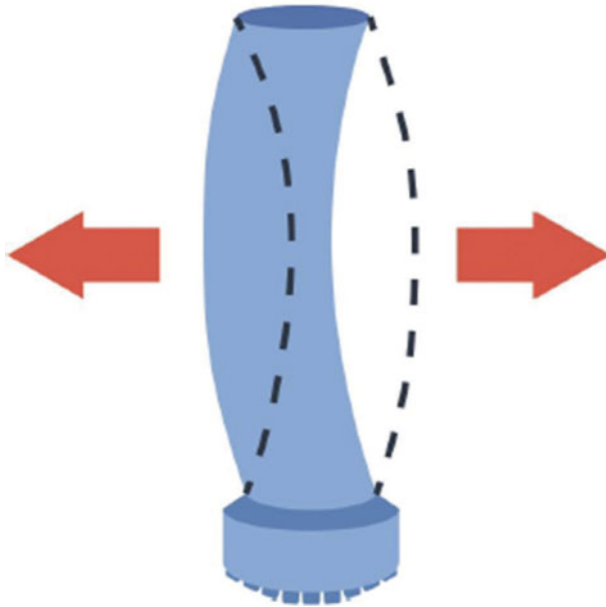

**Figure 6.14** Lateral/transverse vibrations.

The effects of lateral vibrations on bottomhole assembly (BHA) during back reaming operations were evaluated by Agostini and Nicoletti (2014). It was shown that the occurrence of abnormal lateral vibrations during back reaming can effectively cause BHA electronic equipment failure, falling rocks into the well, and drillstring blockage. This in turn can lead to drilling malfunctions. Other works also indicate that the stick-slip vibration on a drillstring length of 3000 m is detrimental to the drilling equipment and the drilling efficiency (Gulyaev *et al.*, 2013).

In order to alleviate the problem of transverse vibrations, the RPM is often reduced, while the WOB is increased. If the vibrations continue, the assembly is picked off bottom, allowing the torque to unwind, and the drilling restarts with different drilling parameters. The energy imparted is also dependent on the free collar length and thus a shorter, stiffer BHA in lateral direction could be implemented to prevent sideways motion.

In the mid-1990s, a new line of anti-whirl drillbits were introduced (Sinor, 1995). Even though the original application of the technology involved coring, it has gained popularity for drilling in difficult-to-drill terrains (Dong *et al.*, 2016).

#### 6.1.6.4 Fatigue

Fatigues are macro cracks in the pipe wall (Figure 6.15). By itself it will not stop the operation, it can develop to real cracks, leakage and then lead to pipe parting, which is a serious problem. This fatigues are the result of continued rapid stress and forces. Moreover, storing the pipe in bad condition, the improper drilling fluid or the formation composition may react with the pipe metals and can lead to pipe corrosions and fatigues.



Figure 6.15 Pipe failure due to twist-off and/or fatigue.

### 6.1.7 Drillstring Failures

The first section of the drillstring is the BHA, including drill collar and drill bit, the two components that are used to crush the rock and create stability for proper directing of the hole. The second section is a heavyweight drillpipe (HWDP) used to provide a flexible transition between drill collars and the drillpipe. These HWDP reduce the fatigue failures that could occur above the BHA in addition to increasing the weight on the drill bit. The third section is the drillpipe that makes up the majority of the drillstring all the way up to the surface. Each drillpipe comprises a long tubular diameter portions with an outside diameter called the tool joints that serve as the connector between two pipes. The pipes are furnished with a male “pin” threaded connection at one end and a “female” housing connection. Such a trait makes the drillpipe flexible yet robust. Throughout the drillpipe, the tool joints have the same diameter, which is slightly higher than the drillpipe diameter. Even though the entire drillpipe has the same diameter, its upper section (closer to the surface) is handled by using a higher strength material for them to be able to support higher axis loading, which is clearly much greater than that of the lower portion. Great advances have been made in terms of drilling speed as well as accuracy. However, there remain several trouble spots that can lead to delay in drilling, thereby costing time and resources.

The cost of drilling a well is measured in tens of millions of dollars. The incidence of downhole failure of the drillstring can increase this figure dramatically. The focus placed on cost reduction in the early 1990s – when oil prices were much lower than today’s levels – resulted in some scrutiny of drilling operations, amongst other areas. Drillstring failure was a natural part of this.

Failure of drillstring is a costly problem in the oil and gas industry. Many studies have addressed the issue, often in considerable detail, but the frequency of occurrence remains excessive. Torque, tension, compression, and bending stresses can be correctly predicted for a known or assumed hole geometry but deviation from this ideal of the actual borehole geometry leads to uncertainty and error in predictions of the stress-state.

Figure 6.16 shows drillstring and bottomhole assembly components where failures continue to afflict the oil and gas industry, annually involving direct and consequential costs extending to millions of dollars. This wide-ranging problem has been exacerbated by recent industry trends towards the drilling of deep, deviated wellbores. Further intensification of the problem may occur if extended reach, horizontal drilling and multiple lateral completion programs become more prevalent.

Drillstring failures, even such routine failures as drillpipe washouts, can contribute significantly to the cost to drill today’s wells. These costs grow

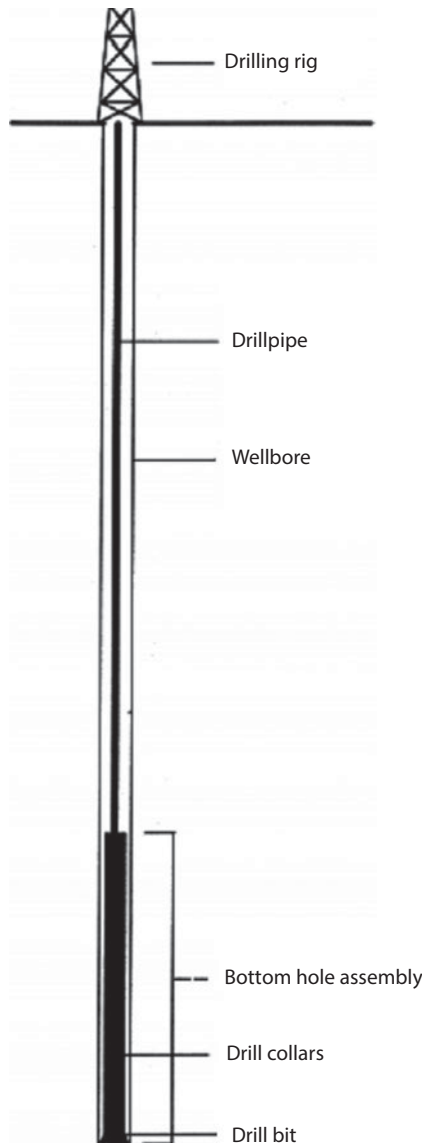

**Figure 6.16** Drillstring (K.A Macdonald, 2007).

exponentially when the failure results in fishing operations, and in extreme cases, failures can even cause well-control problems. In 1985, McNalley reported that 45% of deep well drilling problems were related to drillstring failures. Moyer and Dale concluded that drillstring separations occurred in one in seven wells and cost an average of \$106,000. For such routine failures

as drillpipe washouts, the failure often is accepted as “part of the business”. The offending components are replaced and operations are resumed. If the cause of failure is unusual, analysis must be performed, the results should be reported and recommendations are made to prevent similar failures. These failures seem to be handled case by case without an overall approach to prevention.

Drillstring failure is due to a lot of reasons, which may occur either individually or in-group. In order to prevent or at least minimize occurring drillstring failure, all reasons should be recognized. To do that, one should have a well-designed approach to testing all factors affecting drillstring failure, to eliminate the problem early. Early cases studied were analyzed without an overall approach and without revealing the actual reasons of the drillstring failure.

The range of commonly encountered primary damage mechanisms covers ductile fracture, brittle fracture, fatigue and stress corrosion cracking (Figure 6.17). Various simple and complex combinations can also occur. A consistent feature where twist-off has occurred is that post-separation damage to fracture surfaces can often be very severe, Figure 6.17, obliterating much of the detail of the fracture morphology required to aid identification of the failure mode. This is due to the failure remaining undetected at the surface and consequently both weight-on-bit and rotation continues.

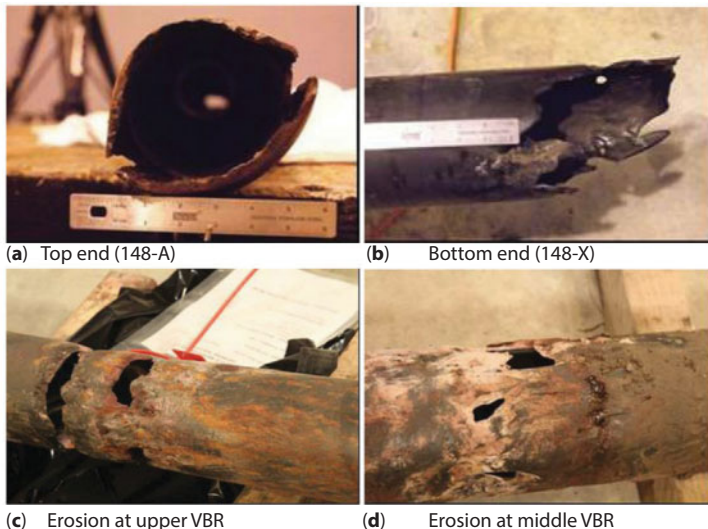
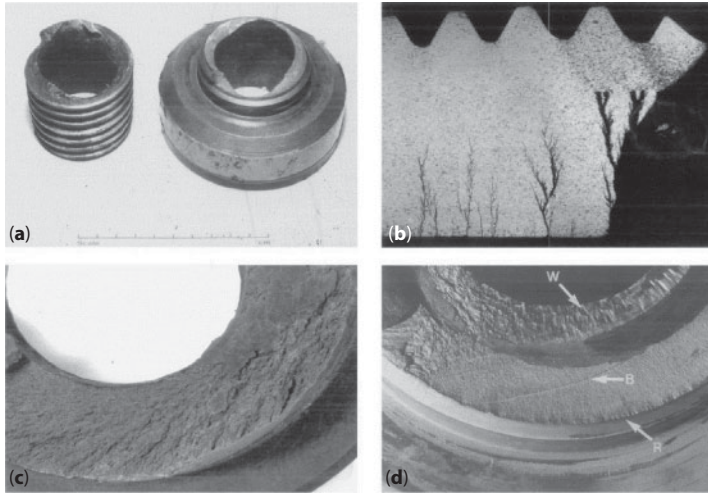

Figure 6.17 Drillstring failure (nola.com).



In addition, the large pressure differential drives flow of the mud from pipe bore to annulus should a leak path become available, resulting in washout damage (Figures 6.18 and 6.19).



**Figure 6.18** Commonly encountered modes of fracture: ductile (a); brittle (b); SCC (c) and fatigue (d) where R – radial steps along initiation region at thread root; B – beach marks from fatigue and W – washout. (Macdonald, 2007).



**Figure 6.19** Post-separation damage to fracture surfaces of a BHA connection. (Macdonald 2007).

### 6.1.8 Drill Bit Jamming

While drilling long sections of an abrasive formation, the gauge protection on the bit and stabilizer can become so worn out that it becomes ineffective. The jamming generally occurs when a new bit is lowered down a hole, previously drilled with a worn out bit. The drillpipe and bit may become jammed when the drilling fluid is not allowed to thoroughly clean the borehole prior to stopping to add another joint of drilling pipe or the fluid is too thin to lift gravel from the bottom of the borehole. In that sense, a driller can anticipate the jamming problem by noting when the drill bit starts to catch while drilling.

Remedies to drill bit jamming are:

- a. If the drill bit and pipe become jammed, stop drilling and circulate drilling fluid until it is freed.
- b. If circulation is blocked, try to winch the bit and pipe out of the borehole. Stop the engine and use a pipe wrench to reverse rotation (no more than one turn or the rod may unscrew!).
- c. If the jamming is related to cutting removal, stop further drilling and allow the drilling fluid to circulate and remove accumulated cuttings from the borehole. Then continue to drill at a slower rate. If it continues to catch, thicken the drilling fluid in order to increase its solid carrying capability.
- d. Properly gauge the bit stabilizer after each run.
- e. Ream back to bottom if an under gauge hole is suspected.
- f. Never force a new bit to the bottom;
- g. Select bits with good gauge protection.
- h. If the new bit is run into an under gauge hole, maximum upwards working / jarring forces should be applied immediately (Baker Hughes INTEQ, 1995).

## 6.2 Case Studies

### 6.2.1 Vibration Control

Okewunmi *et al.* (2007) reported a case study conducted in the Green Canyon area of the Gulf of Mexico for which more than 15,000 ft of salt formations had to be drilled. Offset wells with BHAs, including hole opening devices, were challenged by excessive vibrations that resulted in drillstring twist-offs and fishing. In addition, episodes of low ROP were observed.

Green Canyon area is south-southwest of New Orleans. The deepwater prospect blocks in Green Canyon area hold anticlinal structures with trapped salt formations, some clean and others with inclusions. Salt depth ranges from 10,000-ft to 17,000-ft TVD, depending on sedimentation and formation dip.

The area has produced significant quantities of oil and gas from Miocene and Oligocene sands. The industry's move into deeper waters has provided new opportunities for petroleum production, as well as new challenges. In this well, the sediments are heterogeneous, thus making it difficult to predict the formation layer interaction, since earth movements may have created inclusions.

The drilling of the heterogeneous layers, halite transition zones, sandstone and calcite pose drilling challenges due to vibration, particularly when entering the salt with inclusions in the top or when transitioning into another formation. Destructive vibrations are also observed when exiting salt. Two earlier wells drilled in the same area with similar formation characteristics had catastrophic failures after drilling 500–2,000 ft into the salt.

In both wells, different vendors' Rotary Steerable Systems (RSS) with concentric reaming devices were used to simultaneously drill and under-ream. Due to their operating principles, concentric reamers are inherently more stable than eccentric reamers. Even though, concentric reamer design reduces non-productive time and cost in deepwater application, in the two offset wells drillstring twist-offs occurred due to heavy vibrations. The subsequent fishing operations produced significant delays compared to planned AFE drilling days. In addition, the offset wells showed periods of lower than expected ROP, most likely due to problems in transferring sufficient weight to the bit.

The drilling program for the well was engineered to minimize twist-off risk. A 9-in. CoPilot Drilling Optimization sub was integrated into the BHA to identify critical situations and mitigate them through a drilling optimization engineer's active intervention onsite. It was equivalent to using real intelligence instead of artificial intelligence, as no decision support system was in place. The well's execution phase showed that BHA selection and parameter management were keys to success in the difficult intervals. Accurate information about WOB compared to the weight on the reamer, torque, dynamic diagnostics and RPM provided critical insight into downhole conditions while drilling.

A typical casing program for the ultra-deep wells in the area includes jetting-in a 26-in. casing for the top section below the mud line. A drill-ahead assembly, consisting of a 9-in. positive displacement motor with 0 [Degree(s)] bent sub, drills the well to the casing point for the 22-in.

casing. The 18 1/8-in. × 22-in. section below the 22-in. casing includes the salt formation and is the interval of interest.

Real-time drilling-dynamic information was essential to making adjustments. The 9-in. AutoTrak RSS with concentric hole-opener was selected as a one-pass drilling solution to deliver a smooth wellbore with low tortuosity, precise directional control and thorough hole cleaning. The idea of a bi-center bit was originally considered, but was later rejected in favor of a concentric reamer, due to the latter's superior directional control, low vibration and low risk of creating an irregular spiral hole.

Because data from the offset failures were limited (since both wells were still tight-holed and drilled by different service providers for different operators), real-time drilling data were more useful in creating a dynamic decision support system. A state-of-the-art, drilling-dynamics sub was placed between the 18-in. stabilizer and the 22-in. under reamer.

To minimize BHA radial movement in the borehole, careful attention was given to stabilizer placement and spacing. To select the optimum drilling assembly, various BHA designs were modeled mathematically to simulate the BHA's natural frequency. Graphical presentation of the related mode shapes (radial movement vs. distance from bottom) allowed for a quick interpretation of trouble spots and associated frequencies. Modeling predicted a safe rotary speed and WOB operating range for simulated conditions based on surface parameters, mud properties, and wellbore geometry.

### 6.2.1.1 Execution

Providing accurate information about downhole drilling conditions in real time to surface via the 9-in. OnTrak MWD is challenging. Destructive drilling-dynamic events typically lie in the 0–75 Hz frequency range, thus the standard sensor readings in the MWD tool cannot be observed in real time on surface due to the transmission bottleneck with mud-pulse telemetry. This challenge was solved by analyzing sensor data downhole and transmitting processed data as diagnostic flags. The drilling-dynamics tool was programmed to simultaneously acquire high-rate measurements data (1,000 Hz) from 14 sensor channels and diagnose the occurrence and severity of various drilling-dynamics phenomena. These may be from bit bounce, stick-slip, whirl or lateral vibration. Real-time displays placed in rig offices and on the rigfloor shows the vibration conditions, so that an optimization engineer can communicate with the driller to mitigate an event.

It needs to be emphasized that downhole problem identification in real time is important for an instant reaction at the surface. This process was

absent in the offset wells, as their problems were not easy to identify, hence were difficult to mitigate.

The 18 1/8-in.  $\times$  22-in. BHA, including an 18 1/8-in. pilot-PDC bit, 9-in. RSS with the 9-in. drilling-dynamics tool and a 22-in. concentric reamer, was picked to drill the float of the 22-in. casing, which was set earlier near the top of the salt.

Drilling the interbedded sand-shale formations resumed after a successful FIT. The reamer was mechanically activated by dropping a ball through the center of the drillstring. Upon activation, the reamer diverted some mud flow from the drillpipe through nozzles to clean the reamer cutting elements.

Successful reamer activation was confirmed by differential pressure information from the drilling-dynamics tool. Since less mud flow was circulated through the bit, the differential pressure dropped after reamer activation. This was visible on the rig's surface display in real-time, Downhole delta-pressure displays about 18% at the same flow rate after engaging the hole-opener's cutting blades. The drilling-dynamics tool confirmed an increase in WOB separation between surface and downhole. With this confirmation, drilling resumed.

As the reamer entered the salt, strong oscillations were noticed up to severity levels 4–6, equating lateral vibration signals of 5–15 g RMS amplitudes. At about 200 ft below the top of salt, severe torsional oscillations up to full stick-slip developed. In most drilling operations, a WOB decrease and RPM increase would mitigate this problem. However, the depth-based log in Figure 5 shows that despite increasing RPM from 90 to 135, while backing-off WOB to about 30 klb, the torsional oscillation could not be eliminated. Based on the real-time diagnostic feedback, the onsite optimization engineer identified a stable operating window at 120 RPM with a constant WOB of about 40 klb.

About 300 ft below this point, the bit drilled into an inclusion, and the downhole torque measured by the dynamics tool increased. When the reamer got to the same spot, it reacted to the formation change by taking a lot of weight, slowing ROP. At this point, a strong lateral vibration, BHA whirl, developed. Stopping drillpipe rotation for some time and gradual restarting it did help to overcome the weight transfer problem, however, it failed to eliminate the BHA whirl. It was not until RPM was dropped to 100, while maintaining 40 klb WOB, that a smoother drilling environment was established. The time log documented the onsite engineer's efforts to improve ROP over the rest of the run by decreasing RPM from 120 to 99 to reduce lateral vibration.

Parameter management to reduce or eliminate drilling dysfunctions was successful due to accurate downhole information and proper drilling

team communication. In this well, the rotary speed and the weight had to be controlled within  $\pm 20$  RPM in some intervals without inclusions, up to  $\pm 51$  RPM in intervals with inclusions and within  $\pm 35$  klb WOB adjustments in most cases to mitigate possible catastrophic whirl, lateral and torsional vibration.

The downhole WOB measurement determined the weight taken by the reamer in the drilling process. In the logs, the difference between the surface and downhole weight is the weight taken by the reamer. This insight helped identify situations where the bit was out-drilling the reamer; i.e., the reamer accumulates more weight while establishing its cutting pattern, thus reducing the overall penetration rate. The diagram shows an almost linear increase in ROP while reducing the RPM at the same time. The high variations show that there was no single solution to effective drilling, as long as environmental factors constantly changed. This emphasizes the need for timely, accurate downhole feedback from the drilling optimization tool.

When drilling this vertical well with an underreamer, several severe whirl events were observed, especially below the hole-opener. Whirl is caused by off-center rotation with a drillstring mass imbalance. In some cases, forward whirl develops, which causes eccentric component wear as the drillstring rotates clockwise in the direction of bit rotation.

Backward whirl causes excessive cyclic stress reversal, leading to fatigue as the drillstring center moves around the borehole faster than the applied rotary speed. Several attempts to increase RPM resulted in backward whirl, causing the driller to immediately reduce the rotary speed to prevent BHA failure.

The bending moment describes the bending stresses that drillstring components experience. Bending stresses can be from directional changes in the wellbore or from the drillstring's whirl motion, which causes high, dynamic, bending-stress changes.

### 6.2.1.2 *Lessons Learned*

The most important achievement was drilling this large interval without the occurrence of a drillstring failure or twist-off. This was possible only by improving the downhole drilling environment.

Dynamic measurements and real-time analysis of downhole weight successfully identified the weight taken by the reamer, which can't be recognized by the standard WOB measurement at surface. The dynamics tool also confirmed that the reamer was activated, eliminating another hole-opening trip before the casing was run. Loss of stabilization was also seen as a cause of whirl that could have been detrimental to the drillstring.

Real-time updating and intervention by an experienced dedicated onsite engineer were crucial to successfully drill this section. The engineer's presence helped to establish the required focus for mitigating critical situations. The presence of such personnel amounted to having real intelligence replacing artificial intelligence.

The drilling experience created a valuable database for other wells in the region. The drilling practices established in this section will be used as a standard for this field, where all prior drilling attempts encountered at least one major failure using other equipment.

### 6.2.2 Twist-off

Gundersen and Sørmo (2013) reported a case study involving a Shell operation. Similar to the one described in the previous section, an online decision support system was developed. This AI process had four stages:

1. Data acquisition, involving input data from all available sources;
2. Data interpretation, with data analysis agents at the disposal of main software;
3. Decision support, based on case-based reasoning; and
4. Visualization of symptom and case radar.

Figure 6.20 depicts the decision support system. Shell ran several tests both on historical and live data and has deployed DrillEdge<sup>1</sup> technology since mid-2011. After Shell's experience of a number of twist-off of drillpipe in the region, it requested a software that could predict twist-off problems in advance. By employing this technology, it was discovered that long periods of maxing out the torque while drilling wore out the drill-string so that it finally twisted off. A symptom agent was developed to recognize when the torque was maxed out, thereby collecting data of several cases for which twist-offs had occurred.

By using this technology that involved collecting data from a U.S. land well and five wells from the Middle East, remarkable success was reported. A total of 31 Maxed Out Torque events were fired, which resulted in three of the five Middle East cases appearing on the Case Radar before the drill-string twisted off. The first case appeared on the Case Radar two days before

---

<sup>1</sup> DrillEdge technology is a commercial software owned by Verdande Technology of Trondheim, Norway and Shell. It uses artificial intelligence to understand an incoming catastrophic event, such as twist-off.

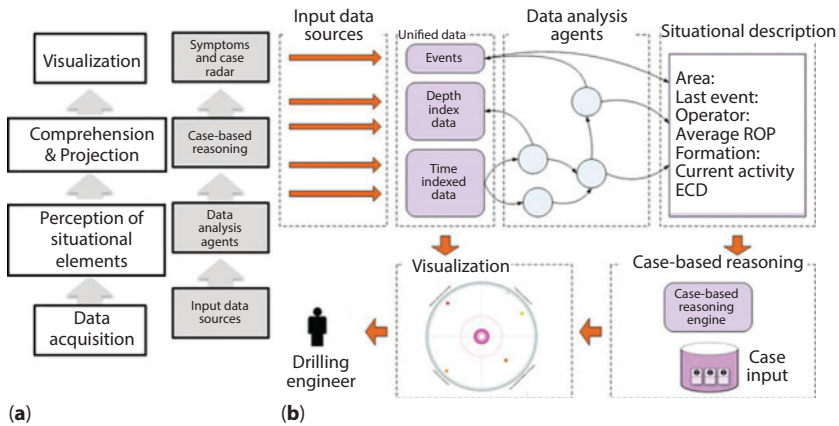

**Figure 6.20** Various stages (a) and data flow (b) information of the case study (from Gundersen and Sørmo, 2013).

the twist-off, providing the operator enough time to react to the problem. Similar success was also reported when data captured from the U.S. land blind test data were used to analyze the Middle East twist-off cases.

In addition to the twist-off tests, the stuck pipe solution was also put under pressure, and predicted stuck pipe six hours in advance. This time frame may be adequate for some applications, but was not deemed useful for the fields of concern.

### 6.3 Summary

This chapter identifies major problems that occur in the drillstring. Various sources of operational difficulties and lost time are identified and solutions presented. A number of case studied established the need to develop a real-time decision support system.

### References

- Aadnøy B S, Larsen K. and Berg P C., 2003, Analysis of stuck pipe in deviated boreholes. *Journal of Petroleum Science and Engineering*. 37(3–4): 195–212.
- Aadnøy, B.S., Cooper, I., Miska, S.Z., Mitchell, R.F. & Payne, M.L., 2009, *Advanced Drilling and Well Technology*. United States of America: Society of Petroleum Engineers, 2009.
- Aadnøy, B.S., Cooper, I., Miska, S.Z., Mitchell, R.F. & Payne, M.L. *Advanced Drilling and Well Technology*. United States of America: Society of Petroleum Engineers; 2009.



- Agostini, C.E., Nicoletti, R., 2014, Dynamic modeling and vibration analysis of oilwell drillstring during backreaming operation, T.i.M.A. I (Ed.), Society for Experimental Mechanics Series (2014), pp. 123–131.
- Altemann, J.A., and Smith, T.B. 1992. Heat Checking/Quench Cracking Tool Joints, SPE-23846-MS, SPE/IADC Drilling Conference, 18–21 February, New Orleans, Louisiana, USA.
- Bailey, L. *et al.*, 1991. *Stuck Pipe Causes, Detection and Prevention*. Schlumberger Cambridge Research, Cambridge, England.
- Baryshnikov A *et al.* A new approach to the analysis of drillstring fatigue behaviour. In: Proceedings of the SPE annual technical conference and exhibition, 30524, Dallas, TX, USA; 1995, October 22–25.
- Corbett, K.T., and Dawson, R., “Drill String Design for Directional Wells,” IADC Drilling Technology Conference, Dallas, March 19984.
- Dale BA. Inspection interval guidelines to reduce drillstring failures. SPE/IADC drilling conference, 17207, Dallas, TX, USA; 1988, 28th February–2nd March.
- DeGeare J, Haughton D and McGurk M. Determining stuck point. In: *The Guide to Oil Well Fishing Operations*. Burlington: Gulf Professional Publishing. 2003. 23–42
- Dong, G., and Chen, P., 2016, A Review of the Evaluation, Control, and Application Technologies for Drill String Vibrations and Shocks in Oil and Gas Well, *Shock and Vibration*, Volume 2016 (2016), Article ID 7418635, 34 pages, <http://dx.doi.org/10.1155/2016/7418635>.
- Grondin, G.Y., Kulak, G.L., 1994, Fatigue Testing of Drillpipe, *SPE Drilling & Completion*, June, 95–102.
- Gulyaev, V.I., Lugovoi, P.Z., Borshch, E.I., 2013, Self-excited vibrations of a drill-string bit, *Int. Appl. Mech.*, 49 (2013), pp. 350–359
- Gundersen, O. E., and Sørmo, E., 2013, An Architecture for Multi-Dimensional Temporal Abstraction Supporting Decision Making in Oil-Well Drilling, Proc. 3<sup>rd</sup> Internaional Workshop, CIMA, Hatzilygeroudis, I. Palade, V. (Eds.), 2013, 156 p.
- Han Yana, Zhao Xuehua, 2014. Failure Analysis on Fracture of a S135 Drill Pipe. *Procedia Materials Science* 3 (2014) 447 – 453.
- Harrison, Glen, “Fishing Decisions Under Uncertainty,” *Journal of Petroleum Technology*, July 1980.
- Helbig, R. and Vogt, G.H., 1987, “Reversed Bending Fatigue Strength of Drill Strings Subject to the Attack of drilling Fluids,” *Oil & Gas European Magazine*, Intl. edition, No. 2.
- Hill, T.H., Seshadri, P.V., and Durham, K.S., “A Unified Approach to Drill Stem-Failure Prevention,” Paper SPE 22002 presented at the SPE/ IADC Drilling Conference, Amsterdam, March 1991.
- Hopkins, C.J. and Leicksenring, R.A., “Reducing the Risk of Stuck Pipe in Netherlands,” SPE/IADC 29422 prepared for presentation at the 1995 SPE/ IADC Drilling Conference held in Amsterdam, 28 February-2 March 1995.
- Horbeek JH *et al.* Successful reduction of North Sea drillstring failures. In: Proceedings of the SPE offshore Europe conference, 30348, Aberdeen, UK; 1995, September 5–8.

- Isambourg, P., Ottesen, S., Benaissa, S. *et al.* 1999. Down-Hole Simulation Cell for Measurement of Lubricity and Differential Pressure Sticking. Presented at the SPE/IADC Drilling Conference, Amsterdam, 9–11 March. SPE-52816-MS.
- Kristoffersen S. Improved fatigue performance of threaded drillstring connections by cold rolling. PhD thesis, Norwegian University of Science and Technology, Norway, ISBN 82-421-5402-1; 2002.
- Krueger, IV, R.E., Philip Wayne Mock, P.W., and Norman Bruce Moore, N.B., 2014, Mechanical specific energy drilling system, US 13/442,642, Sep 16, 2014
- Larsen, L.K., 2014, Tools and Techniques to Minimize Shock and Vibration to the Bottom Hole Assembly, Master's thesis, University of Stavanger, Norway.
- Lianzhong, S. and Deli, G., 2011, A numerical method for determining the
- Lubiniski, A., "Maximum Permissible Dog-Legs in Rotary Boreholes," *J. Pet. Tech.*, Feb. 1961, 175–194; Trans., AIME, 222
- Macdonald K.A. Fatigue of drillstring threaded connections. PhD thesis, University of Aberdeen, UK; 1996.
- Main, Walter C. 1949. Detection of Incipient Drill-pipe Failures. 49–089 API Conference Paper.
- McNalley, R., "U.S. Deep Well Report," *Pet. Eng. Intl.*, March 1985.
- Mechanics, Vol. 12, Trans. ASME, Vol. 67, 1945, pp. A159-A164.
- Miner, M. A., 1945, "Cumulative Damage in Fatigue," *Journal of Applied Mechanics*, 12, A159–A164.
- Moyer, M.C., and Dale, b.A., "Sensitivity and Reliability of Commercial Drillstring Inspection Services," Paper SPE 17661 presented at the 1988 Offshore Southeast Asia Conference, Singapore, Feb. 2–5.
- Norton, Lapeyrouse *et al.* 2002. *Formulas and Calculations for Drilling, Production and Workover*. Book (pp. 72–75) Elsevier.
- Okewunmi, S., Oesterberg, M., Heisig, G., and Hood, J., 2007, Careful BHA selection and adaptive practices help drill a difficult salt section, *World Oil* (Jul 2007): D71-D78.
- Okewunmi, S., Oesterberg, M., Heisig, G., Hood, J., Careful BHA selection, adaptive practices help drill difficult salt, *World Oil*; Houston (Jul 2007): D71–D78.
- RP7G, "Recommended Practice for Drill Stem Design and Operating Limits," 14th edition, API, Washington, DC, 1990, 47, 52–55.
- Russell K A, Cockburn C, McLure R, *et al.* Improved drilling performance in troublesome environments. SPE Drilling & Completion. 2005. 20(3): 162–167 (Paper SPE 90373)
- Santos, H. 2000. Differentially Stuck Pipe: Early Diagnostic and Solution. Presented at the IADC/SPE Drilling Conference, New Orleans, 23–25 February. SPE-59127-MS.
- Schlumberger, 2010, *Drilling Dynamics Sensors and Optimization*. Available at: [http://www.slb.com/~/media/Files/drilling/brochures/mwd/drilling\\_dynamics\\_sensors\\_opt\\_br.ashx](http://www.slb.com/~/media/Files/drilling/brochures/mwd/drilling_dynamics_sensors_opt_br.ashx)
- Sharif Q J. 1997, A case study of stuck drillpipe problems and development of statistical models to predict the probability of getting stuck and if stuck, the probability of getting free. Ph.D Thesis. Texas A&M University.

- Shokir E. M., 2004, A novel PC program for drill string failure detection and Prevention before and while drilling specially in new areas, *Oil and Gas Business*, 1–14.
- Siems G. L. and Boudreaux S. P. Applying radial acoustic amplitude signals to predict intervals of sand-stuck tubing. SPE Production & Operations. 2007. 22(2): 254–259 (Paper SPE 98121)
- Sinor, L.A., Warren, T.M., and Armagost, W.K., 1995, Development of an Antiwhirl Core Bit, *SPE Drilling & Completion*, September, 170–177.
- Speller, F.N. 1935. Corrosion Fatigue of Drill Pipe. 35–229 API Conference Paper. Standard DS-1, *Drill Stem Design and Inspection*, first edition, T.H. Hill Assocs. Inc., Houston, Dec. 1992.
- Trishman L. E. Methods for the improvement of drill collar joints evaluated by full-size fatigue tests. Proceedings of the drilling and production practice, southwestern district division of production, *American Petroleum Institute* 1952:7–20.
- Tsukano, Y. et al, 1988, “Appropriate Design of Drillpipe Internal Upset Geometry Focusing on Fatigue Property,” paper SPE 17206 presented at the 1988 IADC/SPE Drilling Conference, Dallas. Feb. 28-March 2.
- Weiner P.D. A means of increasing drill collar connection life. Trans ASME, *J Eng Ind*; 1972, ASME 72-Pet-65.
- Yarim, G., Uchytel, R., May, R., Trejo, A., and Church, P., “Stuck Pipe Prevention – A Proactive Solution to an Old Problem,” SPE 109914 prepared for presentation at the 2007 SPE Annual Technical Conference and Exhibition held in Anaheim, California, U.S.A., 11–14 November 2007.

# 7

## Casing Problems

### 7.0 Introduction

The most important goal of a drilling operation is to connect the subsurface to the surface facilities. As such, the integrity of the well is of utmost importance. “Well integrity” refers to the zonal isolation of liquids and gases from the target formation or from intermediate layers through which the well passes (Jackson, 2014). Such isolation can be assured with casings, annulus of which is cemented. Drilling companies emphasize well integrity because a faulty well is expensive to repair and, in the rarest of cases, costs lives, as in the *Deepwater Horizon* disaster in the Gulf of Mexico.

Faulty casing and cementing cause most well integrity problems. Steel casing can leak at the connections or corrode from acids. Cement can deteriorate with time too, but leaks also happen when cement shrinks, develops cracks or channels, or is lost into the surrounding rock when applied. If integrity fails, gases and liquids can leak out of the casing or move into, up, and out of the well through faulty cement between the casing and the rock wall.

Much is known and unknown about well integrity. Historical rates of well “failure” in oil and gas fields vary from a few percent of wells with

barrier failures to >40% (Davies, 2014). Analyses of 8,000 offshore wells in the Gulf of Mexico show that 11–12% of wells developed pressure in the outer strings (Brufatto *et al.*, 2003). Similar statistical data are presented for Alberta, Canada, where 3.9% of 316,000 wells showed well integrity problems (Watson and Bachu, 2009).

We have seen in previous chapters, any hole is susceptible to damages such as borehole collapse, circulation loss and rock tensile/compressive cracking, and many others all the way through the completion stage. In this process, casings are the best means of maintaining wellbore integrity in unconsolidated formations and often are necessary even for consolidated formations in view of extended reach drilling and similar complexity. The major function of casing and cement in oil and gas wells is to prevent wellbore collapse during the life of a well. During the drilling process itself, liners are inserted and often cemented in order for the drilling to continue at greater depths. Any operational difficulty encountered during the placement of a casing can lead to damages in the casing-cement system, reducing mechanical resistance of the casing/cement system. Various well events such as drilling, cementing, perforating, well testing, chemical stimulation and others can cause serious well instabilities, eventually resulting in well abandonment. As the need to drill in high pressure and temperature conditions grows, we are faced with a new genre of challenges. As the 2010 *Deepwater Horizon* drilling catastrophe has taught us, often the overall safety of the drilling operation hinges upon the cementing job of a given casing, the failure of which can spell disaster for the drilling operation. For such wells, the casing/cement design is reportedly insufficient because some unique problems do exist when developing such wells.

Little effort has been made in the past to fully understand the instability of cemented sections once they are completed. Often, these casings and their integrity continue to be the source of long-term consequences, while avoiding scrutiny. It is known that, in the perforation zones, casing/cement is subject to instability, particularly in the presence of cavities. Such instabilities can trigger operational difficulties for drilling as well as impact the long-term future of a completed well. In this chapter, we focus on the process of casing placement itself, while giving insight into the long-term stability of the casing and integrity of a well.

## 7.1 Problems Related to Casing and their Solutions

Casing problems can become catastrophic to a drilling operation. Even after the well is completed, casings are pivotal to well integrity. At the very

least, casing problems can incur high cost of repair through workover operations. However, casing problems are not independent of the overall status of a well. As such, solutions to casing problems must be custom designed for each type of problem within the well setting as well as particular geology and overall environment. It is difficult to isolate casing problems from the rest of the well as often the problem is complex and the source cannot be traced properly. However, in this section, major problems associated to casing during drilling as well as during the life of a well will be presented. Also discussed are possible solutions and best remedial practices.

### 7.1.1 Casing Jams during Installation

Because the freshly drilled hole may not be straight, firmly open, or otherwise not fit, casing jamming during installation may occur. Often, boreholes collapse, especially if the hole is slim, extended-reach, or has clay swelling problems.

When the hole is not straight, then the casing digs into the wall of the borehole. Once the casing is 'dug in', it becomes practically impossible to continue the installation process and it must be withdrawn before reattempting.

The problem of borehole collapse is triggered by the presence of the horizontal stresses from the plastic behavior of formation. Salt formations offer the least compressive strength, thereby are most vulnerable to borehole collapse. This is followed by shales. The presence of high temperature and pressure adds to this vulnerability.

Once casing is jammed, it is futile to try to free the casing by forcing it down. Striking it hard in an attempt to drive it may cause the screen to deform or buckle the casing, causing irreparable damages. Also, rotating or pushing the casing down can cause the severe plugging of the screen openings of casing slots, often aggravating the jamming and reducing future functionality of the casing.

In order to avoid casing jamming problems, it is recommended that the operator minimize the amount of pull-down pressure while drilling so that the bit can run freely under its own weight. For a scenario, for which the annular space is deemed small, it is advisable to use a smaller diameter casing or larger diameter borehole, especially in a difficult terrain.

### 7.1.2 Buckling

Buckling occurs under compression that creates instability in a drillpipe or a casing. Because drill collars are used during conventional drilling, the

bulk of the compressive force is imparted on the drill bit and helps with higher rate of penetration. This is not the case for casings that are run without a drill collar. As a result, the weight of the casing has to be sustained by the casing itself. Anytime a casing is exposed to compression during or after placement, it is susceptible to buckling. Buckling occurs when the compressive load and casing/hole geometry create a sufficient bending moment so that the casing becomes unstable. The problem is more intense in case of drill casing, for which the drill bit has to operate on tension for the buckling to be avoided. Such an operation is virtually impossible in absence of drill collars. The lower portion of the drill-casing will support only a limited compressive load before it buckles. After the casing buckles, it loses the ability to support compressive load and starts to use the borehole wall as a lateral support, which can prevent buckling. However, this process is highly unstable and borehole support is not enough lateral deflection for any given set of parameters. Anytime buckling occurs, the following events, with dire consequences may occur:

1. The lateral contact forces between the drill-casing and borehole wall can cause wear on the casing and will increase the torque that is required to rotate the casing.
2. The casing assumes a curved geometry within the borehole that increases the stress in the pipe and may increase the tendency toward lateral vibrations.

During casing drilling, it is important to determine if the casing is buckled. If the casing is buckled, its impact must be assessed so that the above two symptoms can be alleviated. In straight boreholes, the compressive load that causes buckling is determined by the stiffness of the pipe ( $EI$ ), the lateral force of gravity (pipe weight and hole inclination) and distance from the bore hole wall (radial clearance). In a perfectly vertical hole, the portion of the drill-casing that is in compression is always buckled if the bore hole does not provide lateral support through centralizers, just as drill collars are buckled in a vertical hole. If the well is straight, but not vertical, the normal wall contact force from the pipe laying on the low side of the hole provides a stabilizing influence and increases the compressive load that can be supported before the drill-casing buckles.

#### *7.1.2.1 Buckling Criteria*

Hossain and Al-Majed (2015) give relevant design criteria. In this chapter, we limit our discussion to essentials as pertaining to problems that might

arise from drilling perspective. As in casing design, a triaxial check should be made to ensure that plastic deformation or corkscrewing will not occur. The triaxial data help determine the von Mises' criterion, as shown below (Eq. 7.1).

$$Y_p \geq \sigma_{VME} = \left[ \frac{1}{\sqrt{2}} \{ (\sigma_z - \sigma_\theta)^2 + (\sigma_\theta - \sigma_r)^2 + (\sigma_r - \sigma_z)^2 \} \right]^{\frac{1}{2}} \quad (7.1)$$

where,

- $Y_p$  = minimum yield strength
- $\sigma_{VME}$  = triaxial stress
- $\sigma_z$  = axial stress
- $\sigma_\theta$  = tangential stress or hoop
- $\sigma_r$  = radial stress

In this case, a material is said to start yielding when the von Mises stress reaches a value known as yield strength. For the ductile material used here the material factor of safety (FOS) is defined as the material yield stress divided by the von Mises' effective stress.

Buckling occurs if the buckling force,  $F_b$ , is greater than a threshold force,  $F_p$ , known as the Paslay buckling force (Paslay and Bogy, 1964). The buckling force,  $F_b$ , is defined as:

$$F_b = -F_a + p_i A_i - p_o A_o \quad (7.2)$$

where

- $F_b$  = buckling force, lb<sub>p</sub>
- $F_a$  = axial force (tension positive), lb<sub>p</sub>
- $p_i$  = internal pressure, psi,
- $A_i$  =  $r_i^2$ , where  $r_i$  is the inside radius of the tubing, in.<sup>2</sup>,
- $p_o$  = external pressure, psi,
- $A_o$  =  $r_o^2$ , where  $r_o$  is the outside radius of the tubing, in.<sup>2</sup>

The Paslay buckling force,  $F_p$ , is defined as:

$$w_c = \frac{F_p}{\sqrt{\left( w_e \sin \Phi + F_b \frac{d\Phi}{dz} \right)^2 + \left( F_b \sin \Phi \frac{d\Theta}{dz} \right)^2}} \quad (7.3)$$



where

$$F_p = \sqrt{\frac{EI w_c}{r}} = \text{Paslay buckling force, lbf,}$$

- $w_c$  = casing contact load, lbf/in.,
- $w_e$  = distributed buoyed weight of casing, lbf/in.,
- $\Phi_e$  = wellbore angle of inclination, radians,
- $\Theta$  = wellbore azimuth angle, radians,
- $EI$  = pipe bending stiffness, lbf-in.<sup>2</sup>,
- $r$  = radial annular clearance, in.

Table 7.1 gives the relationship between the buckling force  $F_b$ , the Paslay buckling force  $F_p$ , and the type of buckling expected for the tubing. Whenever there is an increase in internal pressure, buckling forces are affected. First,  $F_a$  is increased due to ballooning, which decreases buckling tendencies. Secondly, the increase in internal pressure increases  $p_i A_p$ , which tends to increase buckling. It turns out the latter effect is greater in magnitude than the former, overall impact being an adverse effect on buckling.

It is well known that the onset and type of buckling is a function of hole angle. Because lateral forces tend to stabilize buckling of a casing lying on the low side of the hole in an inclined wellbore, a greater force is required to induce buckling. In a vertical well,  $F_p = 0$ , and helical buckling occurs at any  $F_b > 0$ .

Two models exist for dual-string buckling—namely, the Christman (1976) and Mitchell (2012) models. Recent study indicates that the Christman model tends to overestimate the stiffness of a dual-string system, thus leading to an unsafe design (Li and Samuel, 2017). The Mitchell model assumes an unrealistic space configuration for helical buckling, where the buckling is self-balanced and a dual-string system is independent of the wellbore. As a result, the Mitchell model cannot properly explain the influence of wellbore clearance on the buckling configuration. The Li and Samuel model solves these issues and provides a reliable

**Table 7.1** Buckling criteria.

Buckling force magnitude	Result
$F_b < F_p$	No buckling
$F_p < F_b < \sqrt{2}F_p$	Later (S-shaped) buckling
$\sqrt{2}F_p < F_b < 2\sqrt{2}F_p$	Lateral or helical buckling
$2\sqrt{2}F_p < F_b$	Helical buckling

prediction as a design reference. It is also observed that the outer string in a dual-string system tends to withstand more moments because of greater stiffness. Proper application of this new dual-string buckling model design can help reduce costs.

When it comes to horizontal wells, there has to be a reset of the whole analysis. Figures 7.1 and 7.2 compare how different variables affect buckling in a vertical and a horizontal well, respectively.

Figure 7.2 shows that for a horizontal well, in sharp contrast to a vertical well, the radial clearance, the unit weight and stiffness of the drillstring are all very important variables to consider. Each has almost the same influence on the critical force. There is a negative correlation for the radial clearance because the length at the bottom supports the lowest portion of the wellbore. The higher the stiffness the higher the critical force of the drillstring. That is, it becomes more difficult to cause the drillstring to buckle. The larger the radial clearance between the drillstring and the wellbore the lower the critical force. That is, it becomes easier to cause the drillstring to buckle. A similar conclusion can be made for casings.

Figure 7.3 displays the variables affecting drillstring buckling of an inclined wellbore. The value of the critical force is much lower than that of horizontal wellbore, but the difference gets smaller as the inclination approaches 90 degrees. This behavior is expected.

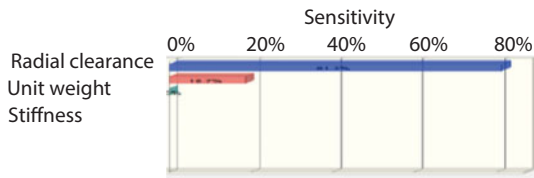

Figure 7.1 Sensitivity of parameters in a vertical well (redrawn from Ifeanyi *et al.*, 2017).

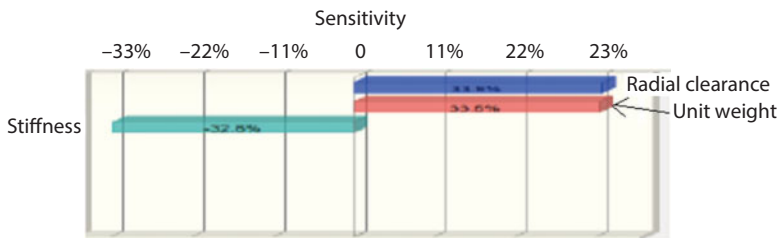

Figure 7.2 Sensitivity of parameters in a horizontal well (redrawn from Ifeanyi *et al.*, 2017).

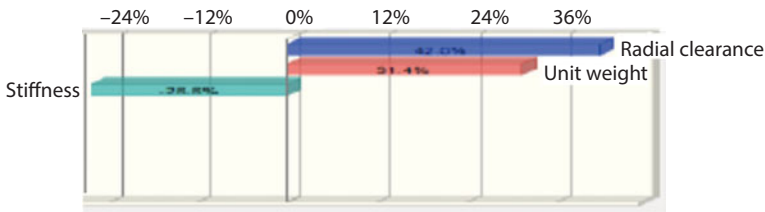

Figure 7.3 Parameters affecting inclined well.

### 7.1.2.2 General Guideline

Buckling should be avoided in drilling operations to minimize casing wear and potential drilltime loss. Buckling can be reduced or eliminated with the following methods:

- Applying a pickup force when landing the casing in surface wellhead after cement set
- Holding pressure while wait on cement (WOC) to pre-tension the string
- Raising the top of cement
- Using centralizers to increasing casing bending stiffness

### 7.1.3 Temperature Effect

The induced thermal stress caused by the significant temperature difference between the wellbore and the surrounding formation can result in the physical damage of casing/cement. In high pressure-temperature wells, which are typical of offshore and some of the most productive formations, casings will face an unusual thermal constraint. Temperature changes and resulting thermal expansion loads are induced in casing by drilling, production, and workovers, and these loads might cause buckling (bending stress) loads in uncemented intervals. We have discussed buckling-related issues in the previous section. In this section, we look into temperature effects. In shallow wells, temperature will typically have a secondary effect on tubular design, including casing design. In other situations, loads induced by temperature can be the governing criteria in the design.

Changes in temperature not only affect loads but also influence the load resistance of casing and tubing strings. The casing material's yield strength will reduce slightly as temperature increases, which in turn reduces the casing burst, collapse and axial ratings accordingly. An increase in temperature affects buckling significantly. With increasing temperature, axial tension is reduced, meaning compression goes up. This reduction in tension may

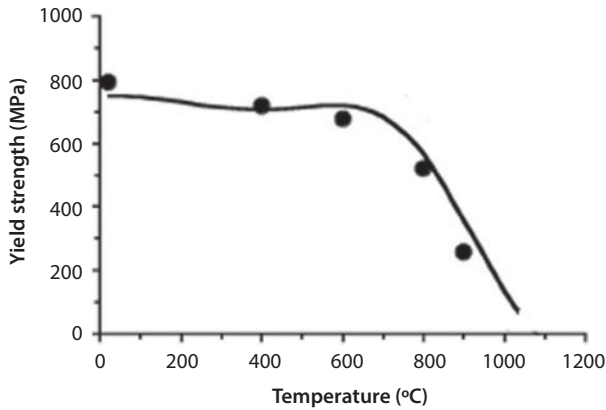

**Figure 7.4** Effect of temperature on yield strength (redrawn from Tancret *et al.*, 2003).

transition the tubing into compression and result in buckling. Figure 7.4 shows the general trend in yield strength for superalloy materials. Even though this figure is derived for superalloy, the general trend is, there is a gradual decline in yield strength with increasing temperature. For casing materials, the decline is sharper and the rapid decline onsets at much lower temperature than 700 C as is the case for superalloy.

Increases in temperature can cause thermal expansion of fluids in casing and tubing annuli. If an annulus is sealed, the fluid expansion may result in significant burst and collapse pressure loads on the surrounding casings. In many cases, these loads need not be included in the design because the pressure can be bled off via wellhead outlets at surface. However, in typical offshore wells, the casing annulus cannot be accessed once the casing hanger is landed and in this case, the annulus fluid expansion pressure must be considered during casing design. The pressure increases will also influence the axial load profiles of the casing and tubing strings exposed to the pressures because of pressure ballooning effects.

Another effect of changes in temperature will be in alteration of tensions in the tubing string because of thermal contraction and expansion, respectively. The increased axial tensile load, because of pumping cool fluid into the wellbore during a stimulation job, can be the critical axial design criterion. The same effect would occur in case the drilled formation temperature is high. In contrast, the reduction in tension during production, because of thermal expansion, can increase buckling and possibly result in compression at the wellhead.

In thermally active wells, the production casing experiences unusual yield and fatigue (for instance, in the cyclic steam injection wells). Also will

be affected is the burst resistance of the casing in a non-isothermal down-hole condition. It is also reported that the casing collapse by the presence of the horizontal stresses may result from the plastic behavior of formation.

#### 7.1.4 Casing Leaks

All petroleum wells produce water. In fact, the petroleum industry in the United States produces more than ten times of water than crude oil (Seright *et al.*, 2003). The world average is somewhat less, the water to oil ratio being around three. The number remains steady as some matured fields are exhausted and new ones are opened. In 2007, when tight gas and oil reservoirs were barely coming into production, the U.S. oil and gas industry was already producing more than 20 billion barrels of wastewater per year, according to Clark and Veil (2009) at the Argonne National Laboratory. The industry's daily output was 5 million barrels of oil, 67 billion cubic feet of natural gas, and 55 million barrels of water, according to federal government statistics. Argonne estimated that more than 7.5 barrels of water were produced for every barrel of crude, and 260 barrels of water for every million cubic feet of natural gas, based on state and federal records for onshore oil and gas production. If offshore production is included, the figures drop slightly to 5.3 barrels for every barrel of crude and 182 barrels for every million cubic feet of natural gas.

Seright *et al.* (2003) pointed out that the produced water has various sources. Table 7.2 shows various sources of water and how they lead to operational problems. Two out of 14 sources are through casings. They are listed as Problems no. 1 and 4 in Table 7.2. However, when it comes to remedies, casings offer an excellent venue to remedy water leaks.

For Problem 1 (in Table 7.2), involving casing leaks without flow restrictions, is where the leak occurs through a large aperture breach in the piping (greater than roughly 1/8 in.) and a large flow conduit (greater than roughly 1/16 in.) behind the leak. This particular case can be remedied with Portland cement. Typically, it involves cement squeezing. This operation is usually performed at the time of running the casing. However, it can be used for remediation of leakage later on in the life of a well. According to MiReCOL (2017), general applications of squeeze cementing are (i) repairing the primary cement job (mud channels, voids, debonding, cement degradation), (ii) repairing casing/liner leaks (corrosion, split pipe), (iii) sealing lost circulation zones (during drilling), (iii) plugging one or more zones in a multi-zone injection well, (iv) water shut-off, (v) isolation of gas or water zones, and (vi) well abandonment.

Squeeze cementing is the process of pumping cement slurry through perforations, holes or fractures in the casing or the wellbore annular space

**Table 7.2** Types of excess water production problems (From Seright *et al.*, 2003)

Category	Problem No.	Description of the problem
Category A: “Conventional” Treatments are Normally an Effective Choice	1.	Casing leaks without flow restrictions (medium to large holes).
	2.	Flow behind pipe without flow restrictions (no primary cement).
	3.	Unfractured wells (injectors or producers) with effective barriers to crossflow.
Category B: Treatments with Gelants are Normally an Effective Choice	4.	Casing leaks with flow restrictions (pinhole leaks).
	5.	Flow behind pipe with flow restrictions (narrow channels).
	6.	“Two-dimensional coning” through a hydraulic fracture from an aquifer.
	7.	Natural fracture system leading to an aquifer.
Category C: Treatments with Preformed Gels are an Effective Choice	8.	Faults or fractures crossing a deviated or horizontal well.
	9.	Single fracture causing channeling between wells.
	10.	Natural fracture system allowing channeling between wells.
Category D: Difficult Problems for which Gel Treatments Should Not Be Used	11.	Three-dimensional coning
	12.	Cusping.
	13.	Channeling through strata (no fractures), with crossflow.

into an isolated target interval, behind the casing or into the formation. Squeeze cementing operations start with wellbore preparation. If the slurry needs to be injected bottom-off, a plug must be installed below the squeeze interval to prevent slurry from flowing further downhole. The slurry is pumped through drillpipe or coiled tubing until the wellbore pressure reaches the predetermined value. In most cases the tubing is pulled out of the cement slurry during the setting period. The next step is removal of excess cement which is usually performed by reverse circulation.

Squeeze cementing is a dehydration process. The solid particles in cement slurry are in most cases too large to enter the formation. In case of

a permeable formation, the solid particles filter out onto the fracture interface or formation wall, while only a liquid filtrate passes into the formation. This results in a cement filter-cake filling in the perforations, as shown in Figure 7.5. As shown in this figure, cement slurry is squeezed into the formation through the filter cake. This process releases excess water into the formation and dehydration starts and takes place instantly. After the accumulation of the filter-cake, cement nodes protrude into the wellbore. Although the filter-cake is not yet set cement, it is impermeable and able to withstand the increased wellbore pressure. After the predetermined setting time has been spent, backflow.

Problem 4 (in Table 7.2), involving casing leaks with flow restrictions, is the case for which the leak occurs through a small aperture breach (e.g., “pinhole” and tread leaks) in the piping (less than roughly 1/8 in.) and a small flow conduit (less than roughly 1/16 in.) behind the leak. The use of gel is favored to successfully treat Problem 4. An array of chemicals have been suggested over the years, including the following as (i) chemically crosslinking water-soluble organic polymers, (ii) water-based organic monomers, or (iii) silicates.

The most common methods to repair casing leaks (i.e., for Problem 1) involve either cement (Marca, 1990). Others have suggested mechanical patches (Bailey, 2000). While these methods work well for larger leaks, smaller leaks (such as Problem 4) are not plugged with these techniques. It's because cement slurry cannot penetrate smaller holes that cause the casing leaks of that variety. For these cases, gel treatments are effective. Such

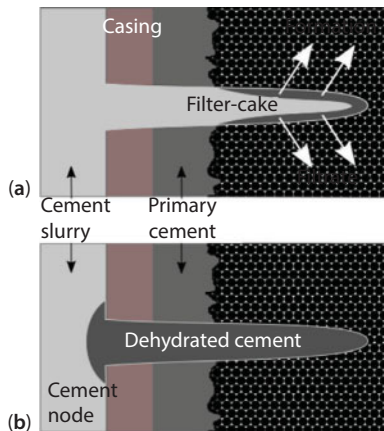

**Figure 7.5** (a) Filter-cake buildup into a perforation channel. (b) Perforation channel filled with dehydrated cement and a cement node is protruding from the perforation.

gels have been suggested by a variety of researchers and many are available commercially (Gel treatments can be more successful for these applications (Jurinak and Summers, 1991).) When properly designed and efficiently executed, these gelling materials can flow easily through the small casing leaks and some distance into the formation surrounding the leak. As such, the plugging occurs within the casing leak as well as the surrounding porous wall. In most cases, the leaks are closed with as small as 1 ft radius around the casing. Consequently, gelant volumes can be quite small. Of course, greater gel volumes and/or other treatment methods may be needed if flow behind pipe or fractures exist in the vicinity of the casing leak.

The leak remediation becomes complex if total stoppage of fluid flow is not the objective. It has been reported by Islam (1993) that several gels, such as silicate based are effective in total blockage but ineffective in allowing preferential flow of oil, in case it is desired to do so. In this case, polymers (such as polyacrylamide) are preferred because of their selective reduction in effective permeability to water. Rigid gels, on the other hand, reduce the total permeability to microdarcies, practically rendering the formation unproductive by forming a non-productive band around the wellbore (Seright, 1994).

Rigid gels can be prepared from several materials that yield permeabilities in the low microdarcy range. Gels for this application have often been formulated with relatively high concentrations (4–7%) of acrylamide polymers having a relatively low molecular weight (on the order of 250,000 to 500,000 daltons). Gelants for this application should be of relatively low viscosity and experience essentially no crosslinking of the polymer during gel treatment placement. One such case is discussed in a following section (Jurinak and Summers, 1991).

### **7.1.5 Contaminated Soil/Water-Bearing Zones**

It is sometimes necessary to drill through aquifers which contain contaminated water. Such zones should be treated with caution. In general, it is recommended that the drilling be continued until a confining layer (clay or rock) is encountered. This way, total isolation of the contaminated zone can be assured. After inserting the casing, the annular space should be sealed with a grout slurry. In order to preserve the grout seal, it should be allowed to cure for at least 12–24 hours prior to resuming drilling. Driscoll (1986) recommended that grout be prepared by mixing 19.7 L (5.2 gal) of water with every 42.6 kg (94 lb) sack of cement. His recommendation was for groundwater wells that are also applicable to oil/gas wells for the surface casings. When 4 volumes of cement powder is mixed with 3 volumes of



fresh water, 5 volumes grout slurry is produced. Alternatively, each sack of cement can be added to a clay-water suspension formed by mixing 1.36–2.27 kg (3–5 lbs) of bentonite with 25 L (6.5 gal) of water (Driscoll, 1986). This mixture helps hold cement particles in suspension, reduces cement shrinkage, improves the fluidity of the mixture and prevents excessive penetration of grout into these formations.

Procedurally, the cement grout is normally placed by just pouring it into the annulus. Alternatively, some grout could also be poured into the casing and/or the casing could be raised several feet and then pushed into the grout that accumulates at the bottom of the borehole. This latter procedure holds a slight edge over the previous one. A continuous operation is the best for a good seal to take effect. Since irregularities in the size of the borehole and losses into formation may occur. For instance, the final volume of the grout is somewhat tentative and the driller must be prepared to augment initial estimates of grout volume on short notice. Where contamination is severe, follow special procedures to ensure that a very good seal around the casing is achieved.

**Tremie Line:** The most common use of grout is to seal the annular space between the top of the filter pack and the ground surface. For shallow wells, the water table does not extend far above the filter pack. It is often possible to mix cement and water (no sand or gravel) into a thin paste and pour it into the annular space. However, in deep wells in which the gravel filter pack is far below the level of water in the annulus, this procedure would lead to separation of the sand and cement leading to formation of a poor seal. To prevent this, the following procedure can be followed:

1. Ream-out the borehole
2. Insert well screen and casing and “float-in” the gravel pack.
3. Insert a 1-inch diameter “tremie” pipe down the annular space to the top of the gravel filter pack
4. Using a funnel, slowly pour cement grout into the tremie line.
5. Gradually lift the line ensuring that the bottom of the line stays below the level of cement accumulating in the annular space.
6. When the annular space is filled, remove and wash the tremie line.
7. Before drilling out the grout plug, the effectiveness of the seal can be checked by measuring water-level change in the casing over time. In wells with a low static water level,

the casing can be filled with water or drilling fluid and later checked for any water loss. If the static water level is high, the casing can be nearly emptied and any influx of water into the casing can be measured.

### 7.1.6 Problem with Depth to Set Casing

A key component of well design is the casing depth selection. The casing depth selection is linked to many other parameters, such as materials or grading on steel, kick tolerances, pressure grading on the wellhead, contingency plan, and others. In practical terms, depth relates to pressure in different well sections, which in turn relates to the formation characteristics. Prior to drilling, geologists must have conducted a thorough investigation of the lithology. Based on the seismic readings and their knowledge they are able to form a lithology profile together with the pressure prognosis of the different formation zones down to target depth. At this point a graph such as in Figure 7.6 should be constructed. Note in Figure 7.6 that there would be a difference between theoretical pressure and the real one. The drilling window during any drilling operation is between the pore pressure (red) and the fracture pressure (blue) lines. At any time there is no window of operation available, one must install a casing in order to continue drilling without risking fracturing the formation (fluid loss and eventual blowout) or blow out. For instance, if the hydrostatic fluid pressure is too low, the formation pressure would be dominant, resulting in an inflow of formation fluids into the wellbore which can lead to a potential blowout. On the other hand, if the hydrostatic pressure goes above the fracture pressure, there would be a severe fluid loss that in itself can create blowout due to loss of hydrostatic pressure. In such a case, the following variables must be

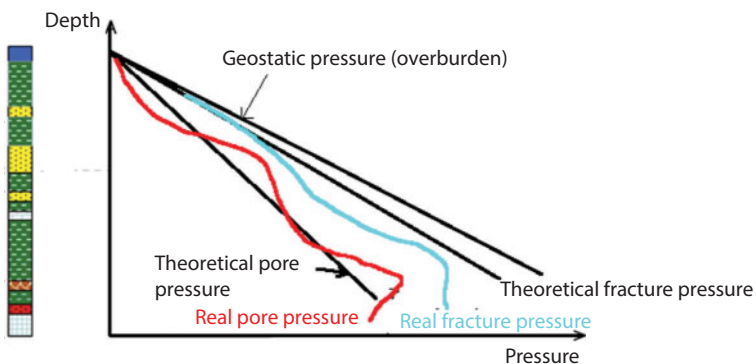

Figure 7.6 Various prevailing pressure in the subsurface.

considered: (i) well profile, (ii) casing setting depth, (iii) mud type, weight and additives, (iv) type of bit for the different sections, (v) torque and drag profile, (vi) casing design with safety factors, and (vii) kick tolerances.

Two main factors determine the depth of the casing shoe. They are: the fracture pressure and the pore pressure. A third factor is the lithology, because it is desirable to place the casing shoe in a competent shale section. The lithology as well as heterogeneity in the formation can result in a variation of the fracture pressures. Methods to predict fracture gradients for deeper wells already exist but need to be refined in order to include heterogeneity and other variables whose impact is not easily determined. Several recent advancements have been made in the predictive tools. For instance, Aadnoy *et al.* (1991) presented a method to predict fracture gradients for shallow wells. Difficulty of such wells is the existence of high pore pressure that invariably exceeds the fracture pressure, making the drilling window non-existent. This method was combined with kick tolerance criteria to yield a casing depth selection method. Also, the variation in fracture pressures at any depth was investigated. The case study of this work will be presented in a later section. Baron and Skarstol (1994) reported practical application of the new method. They showed how the set of equations, based on kick tolerance theory and the driller's method of well control, helps determine the optimum depth for setting surface casing. This application hinges upon understanding the primary purpose for surface casing instead of automatically setting the casing to a depth prescribed by regulations.

This new method is the basis for recent regulation changes on surface casing setting depths in Alberta. The depths determined with the new method compare favorably with the depths currently used by industry.

Difficulties also arise for depleted reservoirs. If too high mud weight is used the result may be fracturing of the formation, leading to significant losses and a possible blowout. While drilling into depleted reservoirs, it is important to determine the last casing setting depth that should be set above and as close to the reservoir as possible since it has a much higher fracture pressure. For casings at greater depth values, additional problems arise, as follows:

1. Drilling pack off in the annulus, e.g., caused by poor cuttings transport. This is a typical problem for deep reservoirs for which the carrying capacity of a mud passes the threshold value, effective for carrying solids. Remedy of this situation is to look into mud viscosity in order to increase its value with viscosifiers, without altering the density.

2. Consistent gel strength of mud is difficult to maintain. If the gel strength of mud is too high, large pressure peaks are induced when circulation is resumed. Additives may be necessary for maintaining such consistency.
3. Casing cement around casing shoe has poor quality.
4. Extensive pressure losses in the annulus leading to too high ECD.<sup>1</sup>

Leak-off testing each well is necessary to ensure that the leak-off gradient is at least 22 kPa/m (about 1 psi/ft). If the gradient is less, an alternative to the driller's method of well control, such as the low-choke method, should be used to circulate out a kick.

The variables in formation fracture theory include lithology, fracture mechanism, mud properties, formation pore pressure, geologic stress, formation age, and depth. Leak-off testing at each casing seat is necessary because of the inability of any theoretical procedure to account for all possible formation characteristics.

#### 7.1.6.1 *Special Considerations of a Surface Casing*

Surface casing has several important functions such as (i) the pressure integrity at the surface casing shoe determines the ability to shut-in the well during a kick, (ii) surface casing protects freshwater sands from contamination, (iii) surface casing isolates the shallow unconsolidated sections to combat drilling difficulties, and (iv) surface casing helps contain surface pressures resulting from a kick.

Surface casing is an integral part of the well control system, just as blow-out preventers and the bleed-off system are. If surface casing is set too shallow, such that a kick cannot be circulated out of the well without exceeding fracture pressure, a blowout may result. Successful kick control requires the well be cased sufficiently to contain the maximum possible surface pressure.

Alliquander (1974) investigated various methods, all based on well control, of determining surface casing setting depth. The method that

---

<sup>1</sup> ECD stands for Alternate Form: equivalent circulating density. This is the effective density that is responsible for creating a total pressure drop in a circulating fluid against the formation that includes the pressure drop in the annulus above the point being considered. The ECD is calculated as:  $d + P/(0.052 \cdot D)$ , where  $d$  is the mud weight (ppg),  $P$  is the pressure drop in the annulus between depth  $D$  and surface (psi), and  $D$  is the true vertical depth (feet).

assumed the well was completely shut-in, and therefore accounted for pressure inversion, showed that for every 10 minutes the well was shut-in, the required surface casing depth doubled. The conclusion was that after a kick is taken, "the hole should be closed for a very short time only," and the driller's method of well control should be used to kill the well.

In general, oil industry regulators believe that a cemented string next to the surface casing or the use of an abandonment plug provides alternative methods of long-term protection for freshwater aquifers. This overshadows the commonly held belief that cementing the surface casing that isolates the entire groundwater zone is the only way to protect the groundwater. By casing-off shallow, unconsolidated formations, drilling problems such as sloughing and stuck pipe can be avoided. Many regulators require casing to be set across an impervious zone or below the lowest occurrence of sand or gravel (Adams, 1980). Casing these zones provides hole stability and ensures that the rock at the surface casing shoe is able to withstand pressures during the circulation of a kick. Thus, the surface casing ensures that only reasonably competent formations are open below for safe well control.

Baron and Skarstol (1994) argued that if the complete shut-in of a well would require unreasonably deep (and therefore uneconomic) surface casing, and if aquifers can be protected for the long-term by alternative methods generally accepted by regulators, and if by providing hole stability surface casing also ensures only reasonably competent zones are open below it for the purpose of well control, then, by elimination, the primary function of surface casing is to allow the successful circulation of a kick. Consequently, the surface casing must be set deep enough so the circulation pressures after a kick are less than the formation breakdown pressure. They provided the general guideline for surface casing depth selection such as (i) 230 m surface casing for a 1,200-m intermediate hole (about 20% of total depth), (ii) 400 m surface casing for a 2,000-m well (20% of total depth), (iii) 1,220 m surface casing for a 3,050-m well (40% of total depth). These depths were based on a variety of assumptions, including initial pit gains from 5 to 16 m<sup>3</sup>.

These depths are much greater than those from industry regulators, who base their requirements on well control and allow surface casing depths of 5–20% of total depth. Well economics, especially if a well is drilled and abandoned, could be significantly affected by the methods proposed by Aadnoy *et al.* (1991).

The following method of determining surface casing setting depth yields depths in the range currently used by operators in North America. Assuming the driller's method (constant bottom hole pressure) of well

control is used, Equation (7.4) can be used to derive a solution for the optimum surface casing depth.

$$P_{choke} + H_{mud} + H_{gas} = P_t \tag{7.4}$$

where,

$$P_{choke} = P - xd_m \tag{7.5}$$

$$H_{mud} = (H - y)d_m \tag{7.6}$$

$$y = \frac{V}{A} = \frac{P_f V_f}{PA} \tag{7.7}$$

$$P = xd_{ff} \tag{7.8}$$

$$A = \frac{\pi}{4}(D_h^2 - D_p^2) \tag{7.9}$$

Equation (7.4) is simplified with following assumptions as (i) the gas gradient is negligible ( $H_{gas} = 0$ ), (ii) the gas behaves ideally ( $P_f V_f = PV$ ), (iii) to tolerate a kick, the kick pressure at surface casing depth must be limited to the leak-off pressure at the shoe.

By using these assumptions and substituting with Equations (7.5)–(7.9), Eq. (7.4) can be rearranged as a quadratic equation (Equation 7.10).

$$(d_{ff} - d_m)x^2 + (Hd_m - P_t)x - \frac{4P_f V_f d_m}{d_{ff} \pi (D_h^2 - D_p^2)} = 0 \tag{7.10}$$

Solution of Eq. (7.10) gives rise to Eq. (7.11)

$$x = \frac{(P_t - Hd_m) + \left[ (Hd_m - P_t)^2 + \frac{16(d_{ff} - d_m)P_f V_f d_m}{d_{ff} \pi (D_h^2 - D_p^2)} \right]^{\frac{1}{2}}}{2(d_{ff} - d_m)} \tag{7.11}$$

where

- A = cross sectional area of annulus
- $d_{ff}$  = formation leak-off gradient at  $x$

$d_m$	=	mud gradient
$x$	=	Point of interest (surface casing depth)
$H$	=	total depth of hole
$P_f$	=	Initial kick pressure
$P_t$	=	Formation or reservoir pressure
$V_f$	=	Initial kick volume
$D_h$	=	hole diameter
$D_p$	=	drillpipe diameter
$H^{gas}$	=	Gas gradient (of kick) in annulus
$H^{mud}$	=	Hydrostatic gradient of mud in annulus
$P$	=	Kick pressure at point of interest (at the surface casing depth, P = leak off pressure)
$P_{choke}$	=	Casing pressure recorded at surface
$P_t$	=	Formation or reservoir pressure
$V$	=	Volume of kick at point of interest
$y$	=	Height of kick

Solving the quadratic equation yields the minimum surface casing setting depth,  $x$  (Equation 7.11). In the derivation of this equation, it is assumed that the kick pressure must be tolerated at the surface casing shoe. The assumption equates the kick pressure to the leak-off pressure at the casing shoe. This key assumption restricts the optimum surface casing setting depth by tolerating a kick only at the casing shoe.

Thus, if weaker formations are below the shoe, an underground blow-out may occur. The most important safety aspect is to control the well at surface. Therefore, the competency of the surface casing shoe is the single most important parameter in preventing a fracture to surface.

#### 7.1.6.2 Practical Guideline

Eikås (2012) presented a practical guideline. When designing a well it is common to start with the supposedly last section to be drilled. Mud weight equivalent to the pore pressure gradient in point A in Figure 7.7 is chosen to prevent inflow from the formation, i.e., a kick. This mud density cannot be used to drill the whole well. At point B in Figure 7.7, the formation will have a fracture gradient equivalent to this weight. The intermediate casing will protect the formation at this point and to surface from the pressure exerted on it from the mud. The intermediate casing therefore has to extend at least to point B. Then the mud density needed to drill to point B and set the intermediate casing is chosen equivalent to the fluid density shown in point C. Choosing mud density at point C implies that the

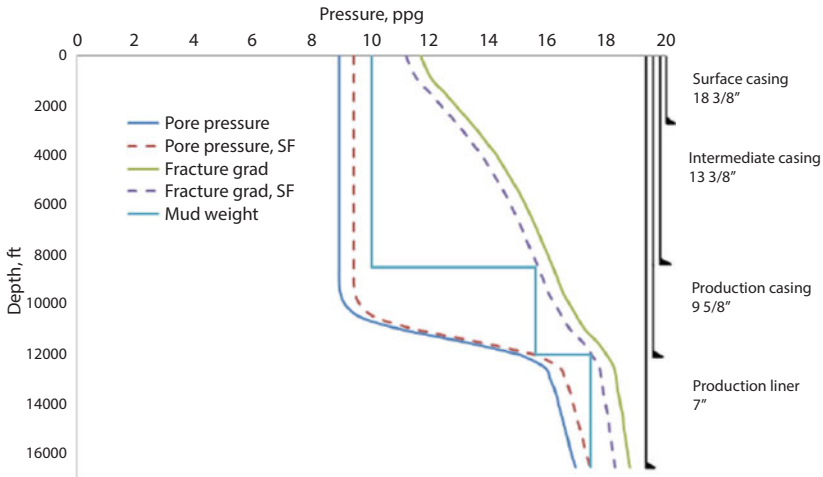

**Figure 7.7** Mud Window with trip margin and correlating Well Design (from Eikås, 2012).

surface casing has to be set at point D to avoid fracturing the formation. All points are if possible chosen on the safety margin line.

Protection of freshwater aquifers, lost circulation zones, salt beds and low pressure zones which may cause stuck pipe are factors that need to be taken into consideration and influence the setting depth. When the setting depth based on mud weight is found, the kick criterion may be taken into consideration.

7.1.6.2.1 Setting Depth Based on Kick Criterion

If the mud pressure cannot withstand the pressure from the formation, a kick may occur. By taking the kick criterion into consideration, the setting depth may be chosen so that the formation in which the casing is set can withstand the pressure it is exposed to during the kick. Using this method, it is important to do the evaluation based on pressure and not the pressure gradients (Aadnoy, 2010). Pore pressure and fracture pressure are therefore plotted in psi versus depth. An example of pore pressure versus depth is shown in Figure 7.8. If the well has been drilled to 12,000 feet and a kick takes place it should be designed to handle this. Assuming the formation fluid at this depth is a condensate with density 7.58 ppg (0.91 s.g.), constant density and no expansion during circulation. When the kick takes place the well will be filled with condensate and the pressure upward in the well will be reduced by the weight of this fluid (Aadnoy, 2010).

In Figure 7.8 the kick fluid gradient is plotted. The point where it crosses the fracture pressure line indicates the new casing setting depth. Repeating



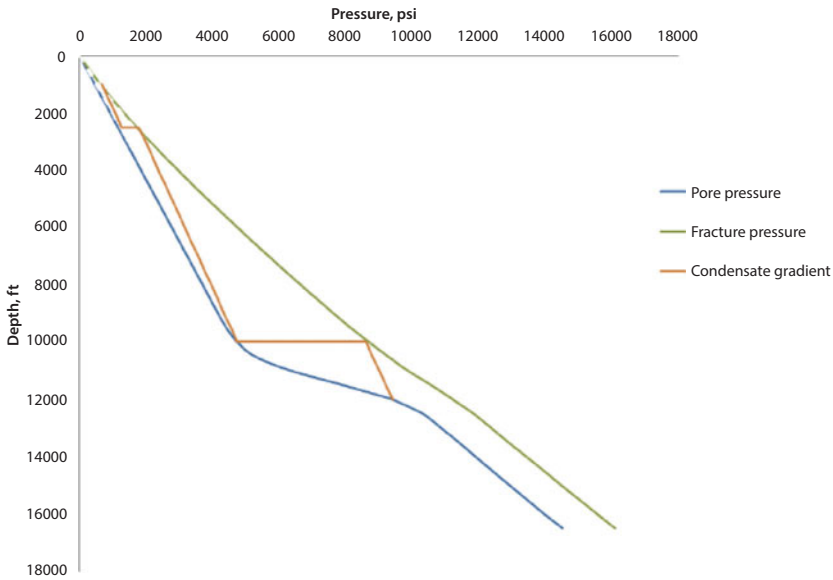

**Figure 7.8** Setting depth based on kick criteria (from Eikås, 2012).

this gives the other casing setting depths. Figure 7.8 shows where the new setting depths have to be to satisfy the kick criteria.

If the well is drilled from a floating drilling rig, the riser margin has to be taken into consideration deciding the casing setting depth. The riser margin is needed in case the drilling vessel has to be disconnected due to, for example, bad weather. In case of disconnection the hydrostatic head created by mud in the riser is replaced by the hydrostatic head of sea water. The pressure difference needs to be balanced. During regular drilling, this is done by applying a heavier mud. The over pressure created is called the riser margin. Including the riser margin in the calculations will affect the casing shoe setting depth (Aadnoy 2010).

#### 7.1.6.3 *Influence of Casing Shoe Depth on Sustained Casing Pressure (SCP) during Production*

The production phase may have special drilling requirements to prevent SCP from arising as a result of unfavorable casing shoe setting depth. This chapter will try to emphasize how setting depth should be chosen to suit the production phase. There are developed some common guidelines that should be followed to ensure well integrity. New drilling techniques have also emerged, such as Managed Pressure Drilling (MPD), Dual Gradient

Drilling (DGD) and drilling with lower circulation rate to reduce the equivalent circulation density. All of these methods may allow drilling further than what would be possible using the conventional drilling method. Using lower circulation rate of mud while drilling may lead to a problem during cementation. The formation may not be able to withstand the necessary pressure required to perform an effective cement job.

During drilling the casing shoe is set as deep as possible based on the mud weight and fracture gradient. To set a casing deeper may therefore be impossible without pushing boundaries and reducing safety factors. A solution on how to enable a deeper setting depth may be to add an extra casing string to the well design. This is done by setting one casing shallower than initially planned and increasing the mud weight. The increased mud weight makes it possible to drill the next section deeper than initially planned and the additional can be set deeper.

#### 7.1.6.3.1 Regulations Regarding Casing Settings

Regulatory bodies are concerned by the potential contamination of surface water or groundwater. Because surface casings are exposed to these water sources, regulations exist in most countries regarding casing placement and cementing operations. In the United States, surface casing depth requirements differ from state to state. However, the majority of the oil-producing states require surface casing to be set below all freshwater (IOGCC, 1992).

A few states (Idaho, for example) require surface casing to be set “sufficiently deep to prevent blowouts” and require all freshwater to be covered. Several states (e.g., California) base surface casing requirements on the depth necessary for well control by a relationship to total depth. California has very deep freshwater (as deep as 900 m) which cannot be feasibly covered by surface casing (SCDC, 1988). To protect freshwater, California requires that intermediate or production casing “be cemented so that all freshwater zones, oil or gas zones, and anomalous pressure intervals are covered.” Indiana’s surface casing rule simply states that surface casing be set “below all freshwater, except where production casing is cemented to surface.”

Some of the state regulatory bodies (e.g., Oklahoma Oil and Gas Conservation Board, for example) that require surface casing only for the purpose of covering freshwater may impose a greater depth for well control purposes if the depth to cover freshwater is too shallow. In Oklahoma, all wells drilled to less than 760 m are not required to have surface casing set through freshwater; rather, the next string must be cemented to cover the freshwater.

The Texas Railroad Commission (RRC) allows alternative freshwater protection programs through an exception process (RCT, 1992). The RRC

may allow companies to set less surface casing providing the first string of casing set through the deepest freshwater is “cemented from the shoe to ground surface in a single stage if feasible.” Also in Texas, any well drilled to less than 300 m is not required to have surface casing set through freshwater, “provided that production casing is cemented from the shoe to ground surface.”

The western Canadian provinces have total depth relationships for surface casing requirements similar to California’s requirements. British Columbia requires surface casing to be set at 15% of planned total depth (BCPRB, 1991). Saskatchewan requires surface casing to be set at 10% of planned total depth. Alberta’s requirements prior to 1993 were 5–10% of planned total depth for developed areas and 12–20% of planned total depth for exploratory areas (SEM, 1991). To protect freshwater, the Energy Resources Conservation Board (ERCB) of Alberta requires that wherever surface casing is set “less than 25 m below any aquifer which is a source of useable water, the casing string next to the surface casing shall be cemented full-length.” (By definition, useable water contains less than 4,000 mg/l. total dissolved solids.) In Alberta, the requirement for surface casing is often waived for shallow wells providing “the casing shall be cemented full-length” (ERCB, 1986). In Alberta, every license to drill a well has the following provision: All useable groundwater aquifers in a well shall be isolated behind surface casing or adequately covered by the cementing of the next casing string or, if the well is to be abandoned, with appropriate open hole abandonment plugs. For drilled and abandoned wells, Alberta’s requirements allow companies to use their abandonment program as a means to cover freshwater.

Of relevance is the Alberta Rule (Alberta Rule, 2018):

**6.080(1) Repealed AR 186/93 s2:**

- 2) The licensee shall set surface casing and meet requirements as prescribed in Directive 008: Surface Casing Depth Requirements.
- 3) Repealed AR 216/2010 s2.
- 2) Where the required surface casing setting depth is less than
  - a) 180 metres, or
  - b) The Base of Groundwater Protection (BGWP) depth, the casing string next to the surface casing shall be cemented full length.
- 3) Notwithstanding any other provision hereof, for any specific well or area, the Regulator may prescribe and require the licensee of the well to ensure that surface casing is installed

at such greater or lesser depth as it considers appropriate in the circumstances.

- 4) The licensee shall ensure that surface casing is cemented full length before drilling more than 10 metres beyond the casing setting depth.

**6.081:** The licensee of a well shall not drill beyond a depth of 3600 metres without first setting intermediate casing unless the Regulator is satisfied that such casing is not required.

**6.090:** The licensee shall cement casing as required by Directive 009: Casing Cementing Minimum Requirements, unless the Regulator

- a) Exempts the licensee from the requirements, or
- b) Prescribes another method for cementing the casing for a particular well or area.

**6.100(1):** The licensee of a well completed to produce oil or gas or to inject any fluid shall leave the annulus between the second casing string and the surface casing open to the atmosphere in the manner described in subsection (2).

- (2) The licensee shall vent the annulus by a line which, subject to such other specifications as the Regulator may prescribe in a particular case, shall
  - (a) have a minimum diameter of 50 millimetres,
  - (b) extend at least 60 centimetres above ground level,
  - (c) terminate so that any flow is directed either in a downward direction or parallel to the ground, and
  - (d) be equipped with a valve where the hydrogen sulphide concentration in a representative sample of gas from the well is found to exceed 50 moles per kilomole.
- (3) The working pressure rating in kilopascals of all parts of the surface casing vent shall be at least 25 times the numerical equivalent of the surface casing depth in metres required.
- (4) The Regulator may exempt a well from the requirements of this section if the well pressures are such that annulus vents are not necessary, or if special circumstances require the vents to remain closed except when checking for pressure in the surface casing.

**6.101 (1):** All production from or injection to a well, except production of sweet gas or injection of fresh water, shall be through tubing.

- (2) The Regulator may, upon application by the licensee, exempt a well from the requirements of subsection (1) where in the opinion of the Regulator, circumstances warrant the exemption.
- (3) A licensee applying for an exemption under subsection (2) shall demonstrate that the measures he has taken to reduce the risk of escape of fluids resulting from corroded materials are adequate.
- (4) Repealed AR 36/2002

**6.110:** No casing recovered from a well shall be run as intermediate or production casing unless it has been tested in a manner satisfactory to the Regulator and shown to meet the Regulator's requirements.

**6.120:**

- (1) Before any fluid other than potable water is injected to a sub-surface formation through a well, the licensee shall
  - (a) set a production packer in the well as closely above the injection interval as is practicable, and
  - (b) fill the space between the tubing and outer steel casing with a non-corrosive, corrosion inhibited liquid, but the Regulator, upon application and in writing, may relieve the licensee from any requirement of this section.
- (2) Where a well is equipped with a production packer as required by subsection (1), the licensee of the well shall, not later than September 1, of each year, submit to the appropriate area office of the Regulator,
  - (a) evidence to show, to the satisfaction of the Regulator, that the liquid between the tubing and the casing is isolated from the fluid being injected, and
  - (b) the data which substantiates isolation.

**6.130(1):** The surface and subsurface equipment of a completed oil or gas well shall be of such nature and so arranged as to permit the ready measurement of the tubing pressure, production casing pressure, surface casing pressure and bottom hole pressure, and to permit any reasonable test required by the Regulator except insofar as a completion technique approved by the Regulator precludes such measurement or test.

- (2) The surface equipment shall include such valve connections as are necessary to sample the oil, gas or water produced.

- (3) The licensee of an oil or gas well, on completion of the well and on any subsequent alteration, shall keep and make readily available to the Regulator an accurate and detailed description of all subsurface equipment in the well and its location therein.

## 7.2 Case Studies

Drilling casings are pivotal components of drilling operation. Casings, being telescopic in nature, if an overburden casing is not properly seated, the problem snowballs and future drilling is severely hampered due to leakage. If it is a matter of continuous drilling, there will be a possibility of stuck-up of string of tools and the drillbit; as a result, the whole borehole will be collapsed. In this condition, mud drilling is needed in order to avoid silting/caving or borehole can be reamed by bit up to problematic area and large casing can be lowered in order to avoid silting and further drilling can be done without any problem. Figure 7.9 shows relative dimensions of various portions of the well. However, it is important to have proper casing placement, otherwise the problem silt will remain and can lead to a snowballing effect.

Much is known and unknown about well integrity. Historical rates of well “failure” in oil and gas fields vary from a small percentage of wells with barrier failures to >40%, many of which are due to casing failures (Davies *et al.*, 2014). Brufatto *et al.* (2009) studied 8,000 offshore wells in the Gulf of Mexico and reported that 11–12% of wells developed pressure in the outer strings (called “sustained casing pressure”), as did 3.9% of 316,000 wells in Alberta. However, not all wells with a single barrier failure leak now or later (King and King, 2013); there can be multiple safety barriers and there must be a pressure or buoyancy gradient for fluids to migrate.

Previous analyses of well integrity in the Marcellus region, where Ingraffea *et al.* (2014) worked, found various results. Considine *et al.*

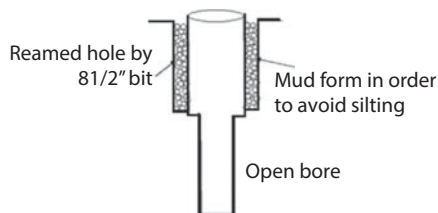
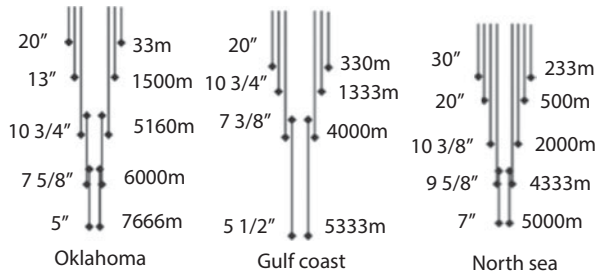

Figure 7.9 Problem in snowball.

(2013) used state violation records to estimate that 2.6% of 3,533 gas wells drilled between 2008 and 2011 had barrier or integrity failure. Vidic *et al.* (2013) extended the timeline (2008–2013) and number of wells studied (6,466) and found that 3.4% had well-barrier leakage, primarily from casing and cementing problems. Davies *et al.* (2014) estimated that 6.3% of wells drilled between 2005 and 2013 had a well-barrier or integrity failure, consistent with Ingraffea *et al.*'s number of 6.2% for unconventional wells. The latter two studies had slightly higher estimates because they included comments from the DEP database in their analyses, including cases where remedial action was taken but notices of violation were not issued. The new analysis by Ingraffea *et al.* (2014) covers more time (2000–2012) and digs more deeply into the data for >41,000 oil and gas wells. There are some surprises. The percentage of wells showing a “loss of structural integrity” (Ingraffea *et al.*'s term) is 1.9% across the period, with the lowest rate for conventional wells drilled from 2000 to 2008. However, unconventional shale gas wells were six times more likely to show problems than conventional wells drilled during the same period: 6.2% compared with 1.0%, respectively. The most common violations assessed were for “defective, insufficient or improperly installed” cement or casing and for pressure build-up, apparent as surface bubbling or sustained casing pressure. In 24 cases the Pennsylvania DEP concluded that there had been a “failure to prevent migrations to fresh groundwater” (Ingraffea *et al.*, 2014). Since 2005, the state has confirmed more than 100 cases of water-well contamination from oil and gas activities (Begos, 2014).

In offshore drilling long casing should be done in sea water up to bottom hard formation of the sea. If the casing is not properly done, Mud density will decrease due to leakage of sea water. As a result drilling cannot be done and there is a possibility back firing due to ‘Mud Loss’ in oil well. That is why, the perfect casing is very essential as far as off shore drilling concerned. In this section, we cite a number of case studies.

The size and setting depth of the casing strings depends almost entirely on the geological and pore pressure conditions in the particular location in which the well is being drilled. As such, there would be a wide range of variability in casing configurations. Some of the configurations used around the world are shown in Figure 7.10. Note how the length of the surface casing depends on the composition of top soil and upper section of the crust. Only the North Sea, where the oil production rate is quite high, uses 7” for the production casing. It is well known that Saudi Arabian reservoirs are the only country that don't install any production tubing and the production is carried out through production casings of 7” diameter.



**Figure 7.10** Some of the casing configurations used around the world (from Khosravanian and Aadnoy, 2016).

### 7.2.1 Case Study – 1 (Casing Jamming)

This particular case study is from Calicut, North Kerala, India. In this coasted area, the overburden casing cannot be placed due to frequent silting problems that give rise to casing jamming and other problems. As a result, the drilling was halted. In this situation, Mud Rotary drilling is needed to arrest silting/caving formation (Anonymous, 2012).

As decided by the regional director, it has been decided to construct one combination well by combination rig (DTH-RECP-88/95 Rig Unit) & a suitable site was selected by site geologist at Calicut. The main objective was to tape top zone & bottom zone by construct rotary well/bore well by DTH Machine. Accordingly, one combination well which consist of 200 meters were constructed out of which 50 meters constructed by rotary drilling for overburden casing as well as, construction of rotary well to tape top zone. A cement ceiling was deemed necessary to arrest back pressure of compressor air and gravel down pressure so that hard rock terrain drilling can be done successfully and 36 hours was given for cement settling time. As soon as cement settling time completed, normal drilling in hard rock was done successfully without disturbing rotary well which constructed at top with screen pipe. This was envisioned by the on-site geologist in order to tape top zone and gravel was surrounded in order to avoid salting by proper “back washing”. If proper cement ceiling is not done, the gravel would fall into hard rock bore due to which the string of tools struck up and further drilling cannot be done by DTH Drilling. The well is discharge 15 LPS (Top zone + Bottom zone) and gravel was surrounded by back wash before develop well.



In boulder/sliding rock/caving/silting area, ODEX drilling<sup>2</sup> can be deployed because, the drilling, reaming and casing would be done simultaneously and silting/caving will not happen due to frequent operation of ODEX system.

It was recommended that in case mud drilling is not available, the problematic caving area/silting area should be reamed by 10"Ø button bit in which 7"Ø M.S. Pipe has to be inserted and sealed at bottom perfectly so that hard rock terrain Drilling can be completed smoothly. This would avoid silting/caving. After completing drilling, the oversize pipe 10"Ø which was inserted to avoid caving/silting may be pulled out if possible.

### 7.2.1.1 Lessons Learned

In problematic boulder area and sliding rock area, casing can be done by odex drilling system.

1. In problematic boulder area, casing can be done by odex drilling system.
2. In order to avoid silting, mud drilling can be deployed for overburden casing in bore well.
3. Big size casing pipe can be inserted by mud drilling in order to avoid silting.
4. Overburden casing should be straight so that, drilling can be done smoothly otherwise there is possibility of fishing/struck up in hole.

### 7.2.2 Case Study – 2 (Casing Installation Problems)

Khosravanian and Aadnoy (2016) reported a number of case studies involving casing-related problems. In early exploration phases, the geological settings of the study area were not thoroughly characterized. The first case involves the Reshadat Field that is located in the central parts of the Persian Gulf to the east of the Qatar/Fars Arch. This structure is located in an area where salt Tectonics has a dominating influence in the formation of structures that are rich in oil and gas accumulations. This area is numerous occurrence of salt plugs, and swelling that accompany virtually all hydrocarbon formations.

**Section 1: Drilling 17.5" hole/13-3/8" Casing:** This hole drilled to 7900–1000 m to provide support to the wellhead and casing and allow for

---

<sup>2</sup> ODEX is a down-hole air hammer system that is designed to advance casing during drilling. Once a desired depth is reached the eccentric bit can be retrieved leaving the casing in place for sampling or installations.

installation of the first BOP stack (or diverter) to ensure safe drilling of the next hole section. A 13-3/8 in. casing string will be run to surface and single-stage cement job will be performed.

**Section 2: Drilling 12-1/4" hole/9-5/8" Casing:** This section drilled from 13-3/8" casing shoe to set 9-5/8" casing at the selected reservoir with casing shoe some 5 min side the formation. This casing will allow installation of the 5000PSI BOP stack to ensure safe drilling of the next hole section.

**Section 3: Drilling 8-1/2" hole/5" Slotted Liner:** The 8-1/2" hole section drilled horizontally from the 9-5/8" casing shoe to the planned section with TD at 74200 m within the selected formation. The setting depth may vary depending on reservoir target, actual conditions, and completion. This horizontal section of the hole will be cased with 5" slotted liner in the hydrocarbon bearing zone and will not be cemented. The 5" slotted liner will be run with the liner hanger set at approximately 100 m inside the 9-5/8" casing.

After a complete analysis of results about objective function we can define an optimum interval that casing points can set in that interval and it depends on the decision maker's risk attitude and different scenario. The upper and lower bound of mentioned interval determine by worst case and good case in geological scenario. If we define other cases, we will find an optimum solution between upper and lower points. Other points out of this interval are not optimum; therefore, it is not an economical condition. Economical measurement specified when we exactly have locations of other points; after that we can compare with optimum solution. Now only can we calculate percentage of profit saving when optimum solution moving between two optimum points as follow in Table 7.3. For example, in well W2 we have three different scenarios A, B, C. The optimum solution in this scenario had maximum 15.2% percent difference in compare of other scenario for profit saving in trajectory.

**Table 7.3** Profit comparison of optimum conditions under different scenarios for various wells.

Well	Trajectory I (%)	Trajectory II (%)	Trajectory III (%)
W2	15.2	3.6	2.4
W7	9.3	3.6	7.3
W19	3.8	3.0	8.7

### 7.2.3 Case Study – 3 (Casing Installation Problems in an Offshore Field)

The South Pars gas field, discovered in 1990, is located some 100 km offshore of Iran in the Persian Gulf and extends into the neighboring country, Qatar, where it is known as the North Field. Main gas bearing formations in the field are the Upper Permian and Lower Triassic carbonate series and Early Silurian dark shales are identified as the main source, South Pars has a 25 phase development scheme spanning 20 years. Optimizing the casing points program is one important factor in well design for offshore applications. Conventional design often dictates that very large surface casing be used to allow passage of a high number of subsequent casing strings telescoping down in size that are required to reach and penetrate target zones. The large casing, the larger surface facilities needed to handle the large casing and the greater level of services needed to support drilling and completion of these larger holes increases exploration and field-development costs significantly. The wells in this study have been divided into the components shown in Figure 7.11. The following drilling programmed carried out for the wells by utilizing a jack-up unit in the South Pars gas field. Table 7.4 presents a comparison between previous practices and the one recommended after the decision support analysis.

The goal of this case study is to compare the results of decision-making with and without accounting for new approach. The decision-making here relates to the definition of the best casing points of wells. The goodness of the objective function of the new approach and implemented plan of previous phases of field was checked by the Table 7.4. Comparison between the objective function of the new approach and the implemented plan show that the previous plan is not better than the new approach. It is important also to notice here that using the previous policy for all the casing points selection of the completed wells of field may be the worst solution for future phase.

The following important improvements in percentage were achieved through the use of the “new approach” concept for previous phase wells: these available results for 15 wells could be used to find the best approach. For this case study, the average of objective function including new approach was smaller than the average gain of excluding new approach.

#### 7.2.3.1 *Lessons Learned*

This case study demonstrates the importance of optimizing casing placement with consideration of all available data, including geology and production history. An optimization procedure to plan optimum casing

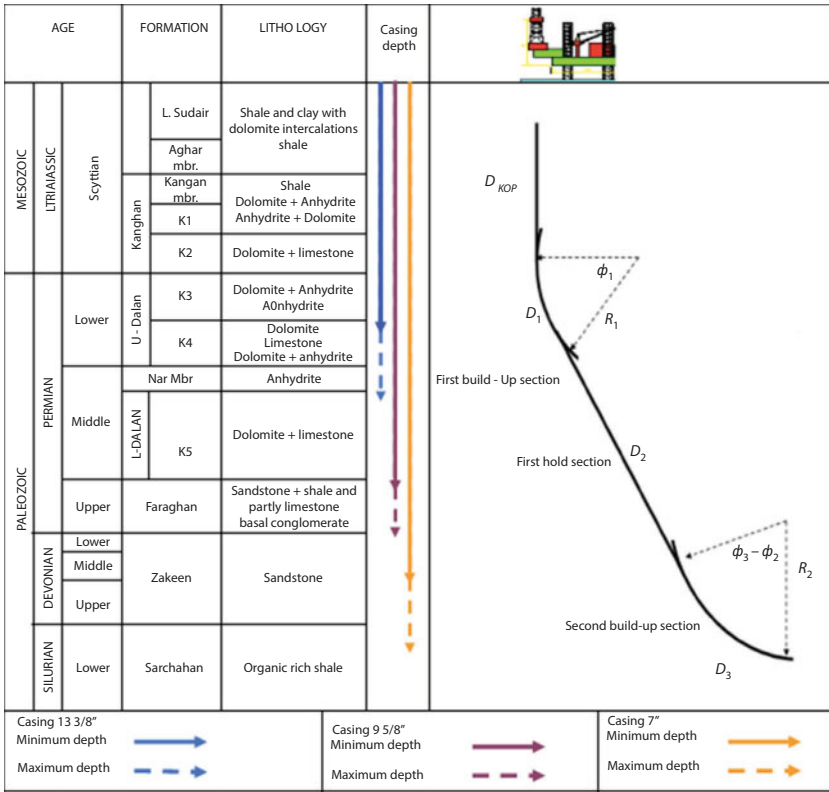

Figure 7.11 Well path is suitable for well completions of optimization well design problem.

Table 7.4 Comparison of results between new approach and previously practiced approach.

Phase	Number of wells	Scaled sum of objective function for all wells		Percentage (%)
		With implement plan solution	With new model solution	
Phase 1	4	60	58	3.33
Phases 2 & 3	5	78.5	74	5.73
Phases 4 & 5	6	96	91.2	5.00

points in three-dimensional, directional well-path has been presented and successfully applied to an offshore project in Iran. The results of the study show that the new method had a significant potential to increase efficiency and reduce cost, time, demonstrating a cost saving. Not only does the new approach applied for drilling operation of offshore project but it also will be the basis for other drilling operation phases in future because it gives satisfactory results.

The following conclusions are drawn in this paper; mathematical modeling is applied for the optimization of the casing point selection under geological uncertainty. The observations from this study are: (i) the utility framework was utilized to assess the uncertainty in mathematical modeling when evaluating different well trajectories and geological scenarios, (ii) the utility framework provides the tools to quantify risk attitudes through utility functions, and (iii) the utility framework transformed the uncertain problem into a deterministic one.

On average over Reshadat Field, the consideration of geological uncertainty, through multiple scenarios using the full approach, provides better decisions regarding the best points of wells, as savings at least of 2.4–15.2% are predicted. The casing point Planning (CPS problem) extension to the uncertainty environment is a good tool to determine casing setting depths of wells.

The more data available, the smaller the uncertainty and the better the decisions.

#### **7.2.4 Case Study – 4 (Leaky Casing)**

*Oil and Gas Journal* (*O&G Journal*, 1990) reported a successful operation that cured leaky casing problems. A well operated by Mainland Resources (O.S.) Ltd. in Indonesia faced lingering problems with leaky casings. The well was located in the Bunyu field, discovered in 1922. This field has 123 wells drilled with one dry hole in a complex series of channel sands interspersed with shales and coals. Approximately 91 zones have been produced during this period. Cumulative production is approximately 80 million bbl of oil. Although most wells produce with high water cuts, pressure maintenance and improving the sweep efficiencies across the channels by careful placement of injection points can substantially improve recovery.

Mainland Resources (O.S.) Ltd. is a secondary recovery contractor that obtained the rights of evaluating, installing, and operating the waterflood project in the Bunyu field. The field is on the relatively isolated Bunyu Island off the east coast of Kalimantan in Indonesia. Initial pilot installation work commenced in July 1987 in several zones.

Well B-49, drilled in 1973, was proposed as a producer well for the 0–95 zone water flood pilot. This well was chosen because of its location within the desired pilot area, and because the drill stem tests, in July 1985, showed the well as a desirable producer for waterflooding. The well had been abandoned in the zone at uneconomic primary rates and was slated to be activated during the secondary recovery phase.

This testing was on natural flow, and the well was originally completed to produce in this manner. To save early production cost, installation of artificial lift was planned for a later date. Water cuts were expected to rise to 90% and above sometime after production started. Note that the reservoir was already on a waterflooding scheme and a high water cut was expected due to water injection. However, such high water cut reduced the economic appeal of the well and natural production had to be halted sooner than expected.

Because large volumes of water would be produced to maintain economic oil rates and with other considerations, including the capacity limitations of the existing gas lift system, electric submersible pumps (ESP) were chosen as the preferred lift method.

The ESP was installed without difficulty, and the well was placed on production. Similar to most oil wells in Bunyu, many zones in well B49 had been perforated previously for production, and cement squeezed when the zones were abandoned. In general, good primary cementing in Bunyu is very difficult to obtain and is generally poor, especially in the old wells such as B-49. Apparently because of the combination of poor primary cement and poorly consolidated sandstones, breakdown of primary cement and shallow squeezes occurred whenever subjected to pressure drawdowns of ESP'S.

The previous array of testings in 1985 needed difficult squeeze work to prepare the well. Those jobs were examined closely in an effort to improve upon the methods used. Although great care was taken to ensure good squeeze jobs, including testing various cement mixtures and placement techniques (different methods of hesitation squeezing, pump rates, etc.), some squeezes still required multiple jobs with increasing costs to obtain the required casing test results. Much was learned regarding the formation competence and problems associated with utilizing the old wells.

#### *7.2.4.1 Repair Alternatives*

Additional pump testing resulted in additional breakdowns, finally requiring temporary abandonment for safety reasons. It was apparent that additional squeezing of these perforations would most likely be unsuccessful

and not cost-effective. An evaluation was made to determine the optimum method of repair to bring the well back on production. Alternatives included:

1. A complete resqueezing program with a special epoxy-based resin cement which needed to be designed and ordered from the United States.
2. Setting approximately 160 ft of casing patches, which also at the time needed to be ordered with setting tools and a serviceman stationed in Indonesia.
3. Isolating the bad section of pipe with a special packer, complete with electrical feed-through and individual vent line to surface.
4. The possibility of setting a 4 1/2-in. liner (5 1/2-in. pipe was not available) through the bad casing sections, which would then require a different lift mechanism, as submersible pumps were not available small enough to fit this size casing.
5. Drilling and completing a completely new twin well on location, a rather expensive prospect.
6. After evaluating all factors, such as cost, logistics, reliability, and production rates required, the casing patch alternative looked best. Although these were new in Indonesia, the one other operator with experience with the casing patch had been very satisfied with the cost effectiveness service, and results.
7. Patch materials on hand could also be used in the other pilots that were being installed, thereby reducing future workover and ultimate project costs.
8. Casing patches will not improve zone isolation behind the pipe. But it was felt that if the differential pressure across a cement squeeze into the casing could be borne by the patch, the cement could maintain zonal isolation behind pipe (casing-formation annulus) with a much lower vertical (formation-to-formation) pressure differential than horizontally (formation-to-casing) across the old perforations.
9. The patch materials and setting tool were ordered and preparations made to perform a nine-patch casing repair operation.

#### 7.2.4.2 *Setting Patches*

The patches were set using the setting tool, circulating break-out sub and drillpipe system. A marker sub was located above the setting tool to

position the first and lowest patch accurately over the perforations. Marker sub depth was located with a wire line gamma ray and CCL.

The deepest patch was set first. The first 5 ft were hydraulically set using 2,500 psi and then the remaining length set by straight rig pull of 50,000 to 60,000 lbs. A bar was dropped to break the circulating sub plugs and the tool was pulled out of the hole.

The second patch was rigged up and lowered into the hole and the first patch tagged. It was then pulled up hole until it was located opposite the second set of perforations to be patched. The wire line gamma ray and CCL was run again to verify the location. The second patch was then set using the same procedures as the first. In the same manner, the remaining seven patches were set. The overall time to set the nine patches was 104 hr.

#### *7.2.4.3 Results and Lessons Learned*

No downtime due to squeeze breakdown or indications of casing leaks occurred during the first 7 months on continuous production. The well pumped a stabilized 2,250 bbl of fluid/day, almost one-third higher than the rates that previously caused breakdowns.

The patches were exposed to differential pressures of up to 700 psi. Although some of the rig work prior to patching would have been required for various reasons including pump testing, it is estimated that 65% of the rig and associated cementing costs were solely attributable to repair of the cement breakdowns. This cost would have been even higher if not for the fact that the ESP did not require replacement. The total cost of the patch work was approximately \$70,000, including rig time and reflecting the high logistics costs involved in this remote area. This well was an exceptional case due to the many old perforations, and the fact that this was the first producer completed.

However, eliminating similar completion problems on future wells by utilizing casing patches is expected to provide savings of up to \$60,000 per producer. Savings are based on rig work, with workover time reduced by approximately 4 days.

The location of the patch was set in the casing over perforations or other type leaks. It formed a thin wall cylinder in the casing, reducing the internal diameter by only 0.31 in., thus allowing packers or other remedial operations to take place whenever necessary. The patches effectively sealed off the leaks and was strong enough to withstand both internal and external pressures. The patch was composed of a long, thin metal tube, corrugated in an 8 or 10 pointed star shape. This shape reduces the outside diameter so it can be run downhole. The outside was covered with a layer of glass cloth or



other material depending on the application. As the patch was lowered into the casing, a layer of special epoxy coating was applied. The coating had a gel life of 608 hr before it hardens. The epoxy and glass cloth form a permanent seal between the casing and patch when it hardens. The patch length was designed to cover the leaking area and extend approximately 8 ft on each end into good casing. The setting operation forced the patch to conform to the casing ID and puts the patch in compression. After the first 3 to 4 ft were set, the patch was firmly anchored to the casing and remained stationary.

The setting tool is a series of hydraulic cylinders actuated by pump pressure. The cylinder rod extends below the setting tool in the opened position. Attached to the rod were extension rods long enough to accommodate the length of the patch. To these were attached a solid cone wedge and a powerful flexible collet. The patch was installed over the extension rods and between the cone at bottom and a liner stop at the top. On top of the hydraulic cylinders various tools were attached, determined by the type operation. Combinations of tools can be holddown, bumper sub, slide valve and tubing or breakout plug-type circulating valve, and drill pipe. The procedures and operations to set a standard patch were as follows:

1. The leak depth was located using packers. A casing scraper was run to clean the scale, cement, etc., out of the section of casing to be patched.
2. A gauge ring was run to verify that the casing was not undersized. The setting tools and patch are assembled and positioned above the well bore.
3. A two-part epoxy was mixed and as the assembled tool was lowered it was applied to the fiber glass cloth on the patch. The assembly was then run downhole and centered over the leak.
4. The slide valve allowed the tubing to fill up going downhole.
5. While positioned over the leak, the slide valve was closed and pump pressure was applied. This activated the hydraulic cylinders that then pulled the cone and collet into the bottom of the patch and sets the bottom 5 ft.
6. The star-shaped patch was forced to conform to casing ID. The epoxy formed a cylindrical seal between the casing and patch and was also squeezed into the leaks occurring in the casing.
7. After the first 5 ft of patch is set, the pump pressure was released and the working string raised 5 ft. This stroked the tool open, and it was ready to set an additional 5 ft hydraulically.

A second method of setting the remaining patch was a straight pull on the working string. The patch was anchored to the casing after the first 5 ft were set so either method can be used. Either system allows the working string to drain while coming out of the hole. Additional patches can then be run or other operations begun. If the patch is to be pressure tested, it can be done after the epoxy hardens, 24 hrs from the time it was mixed.

### 7.2.5 Case Study – 5 (Use of Gel for Water Leaks)

Jurinak and Summers (1991) presented a case study that involved colloidal silica gel for water leakage control. Colloidal silica gel system that can withstand up to 250°F and passed a series of high performance tests was selected. Colloidal silica was selected for extensive investigation because its gelation is less sensitive to salinity and pH variations than the gelation of silicates is, providing more reliable gel-time control. The higher silica concentrations required for colloidal silica gel than for silicate gels was accepted as a necessary consequence. Colloidal silica gel has been used in 11 well workovers for water-injection-profile modification (four wells), water-production control (three wells), and remedial casing repair (four wells).

Colloidal silica gel was used in 11 well treatments between Sept. 1985 and April 1988. Table 7.5 provides a chronological summary of the field work.

The treated wells represent a spectrum of reservoir lithologies, including tight consolidated sandstone, high-permeability unconsolidated sand, dolomitic sandstone, and carbonate. Static reservoir temperatures ranged from 70 to 180 °F and formation brine salinities varied between 1 and 16% total

**Table 7.5** Summary of Field Applications.

Date	Well	Location	Treatment
September 1985	I-1	Southeast New Mexico	Profile modification
Oct. – Dec. 1985	C-1 through C-3	South Texas	Casing repair
July 1986	C-4	Southeast Oklahoma	Casing repair
Sept. 1986	P-1	Offshore Louisiana	Water shutoff
Jan. 1987	I-2	Southern California	Profile modification
Feb. 1987	I-3	Southern California	Profile modification
March 1987	P-2	Southern California	Water shutoff
March 1987	I-4	West Texas	Profile modification
April 1988	P-3	Offshore Louisiana	Water shutoff

**Table 7.6** Properties of Ludox and Sodium silicate solutions.

	<b>Ludox</b>	<b>Sodium silicate</b>
Average particle diameter, mm	7	1
SiO <sub>2</sub> , wt.%	30	29.1
pH at 25 °C	10.2	11.1
SiO <sub>2</sub> /NaO <sub>2</sub> , wt.%	52	3.3
Viscosity at 25 °C, cp	5	300
Weight, lbm/gal	10.1	11.6
Specific gravity	1.22	1.39

dissolved solids (TDS). Only one of the four injection-well treatments was a clear-cut technical success, with failure typically caused by pressure parting the gel plug after the well treatment. Two of the three water-production-control jobs were technical and economic successes. Temporary success was achieved in three of the four casing-repair treatments. Du Pont Ludox® colloidal silica (7-nm particle size) was used in all the laboratory work and field testing. The properties of Ludox colloidal silica sol are given in Table 7.6, along with analogous properties for a 3.3:1 sodium silicate.

The casing repair cases involved the South Texas Wells of for sections C-1 Through C-3. Colloidal silica gel was used to patch small casing leaks in three shallow injection wells operated in a large south Texas field waterflood. These were 1,500-ft wells that penetrated multiple water sands at depths ranging from 400 to 1,200 ft. The casing damage was caused by mildly corrosive in situ water during the 30 years of field operation. Mandated casing integrity tests are conducted by hydro testing the tubing/casing annulus at 500 psi, with no more than 25-psi decline allowed over the 30-minute test interval. Test failures in this field indicated leaks that are often not detected and remedied with conventional approaches. Each treatment followed a similar procedure (Figure 7.12).

During the remedial operation, the waterflood packer was released, and the tubing/casing annulus was filled with preflush solution by injection down the annulus. The packer was reset, and preflush brine was pumped into the leaks for 4 to 7 hours. In each case, the net preflush injection into the leaks was less than 1 bbl. Silica solution was squeezed into the leaks in a similar manner. The injection rate was maintained low enough in each case so that water injected on top of the silica-solution column would not displace water deep enough in the casing to flood a shallow leak. The injection pressure was at least as high as the final system test pressure of

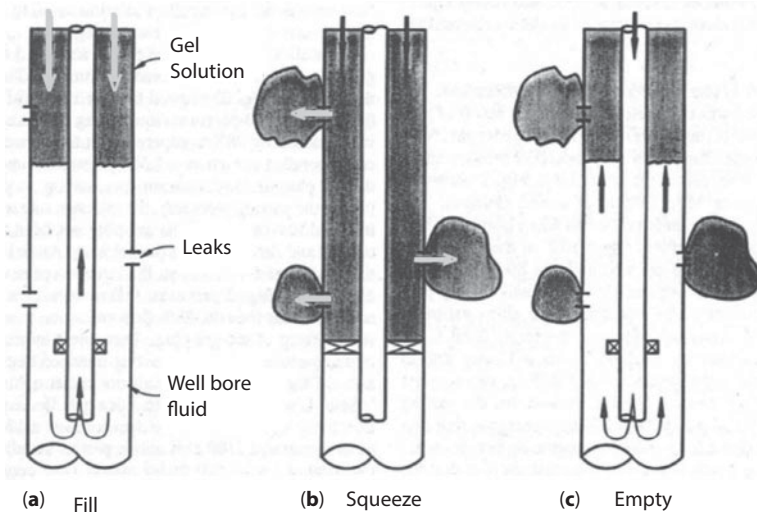
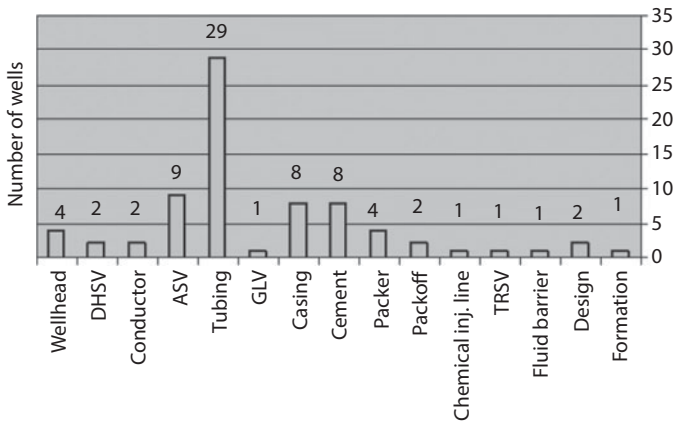

**Figure 7.12** Casing repair procedure used in South Texas field.

500 psi. In all cases, less than 1 bbl of silica solution was injected after the leaks were squeezed for 5 to 7 hours. The packer was released after the estimated time of solution gel time and the silica solution circulated out of the annulus with a packer fluid. This left the annulus clear but the leaks plugged with silica gel (Figure 7.12). The silica-solution recovered after the flushout that the gel viscosity was maintained at around the gel point. The wells were shut in and then pressure tested the next day. All three wells passed the casing-pressure integrity test immediately following treatment. All three wells were retested about 6 months after treatment. One well had developed a tubing leak and was not tested. One well failed the test, showing a 50-psi pressure decline over 10 minutes. The third well tested within standards. Although the gel squeeze procedure successfully repaired small casing leaks in the test injection wells, the underlying cause of the casing degradation was not addressed by the silica gel. Consequently, new leaks ultimately formed, and it appeared that the retreatment frequency could be as often as every 6 months. This may be economical only if the workover cost is low to medium.

### 7.2.6 Case Study – 6 (Unusual Lithology)

A case study of a field offshore Norway has been performed (Aadnoy *et al.*, 1991). The preliminary conclusions are that the 30-in casing setting depth is difficult to model, whereas the 20-in casing string could be set

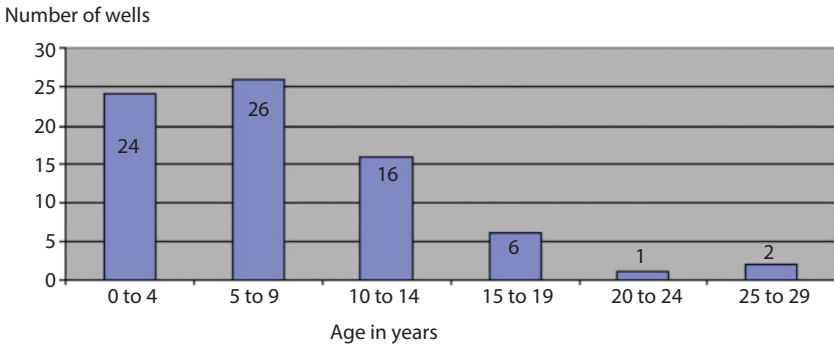

**Figure 7.13** Number of wells suffering from different barrier element failure (from Vignes & Aadnoy, 2008).

at shallower depths. The large spread in leak-off pressures of the field has been investigated further. Some of the spread is found to be caused by the failure mechanisms of the rock and is therefore unpredictable. Part of the spread in observed fracture gradients, however, seems to correlate with mud properties. Improved hole strength is, therefore, possible by formulating a proper mud.

In 2006 a “pilot well integrity survey” was performed by the Petroleum Safety Authority Norway. The objective of the project was to determine to what extent wells on the Norwegian Continental Shelf suffer from integrity problems (Vignes, *et al.*, 2006). Figure 7.13 shows various types of well integrity problems emerging from the survey (Vignes and Aadnoy, 2008). Seven companies were contacted and asked to share information concerning well conditions on pre-selected offshore facilities. To get a representative selection of wells both injectors and producers were assessed. The range of wells varied in age and had different development categories.

Figure 7.14 indicates that wells from 1992 to 2006 represent a peak for integrity occurrence. Of the 406 wells that were evaluated, 75 were found to be suffering from an integrity problem. The majority of these wells are from the early 1990s (Vignes *et al.*, 2006). Figure 7.14 shows some of the different leak paths that can develop within a well. Some common failures that result in sustained casing pressure (SCP) are: leaks through casing or tubing, intrusion of fluids from surrounding formations and leaks through packers and wellhead seals (Vignes & Aadnoy, 2008). Various cases of SCP were identified and solutions proposed to remedy each case.



**Figure 7.14** Age of wells with integrity issues. 75 out of 406 wells show integrity problems.

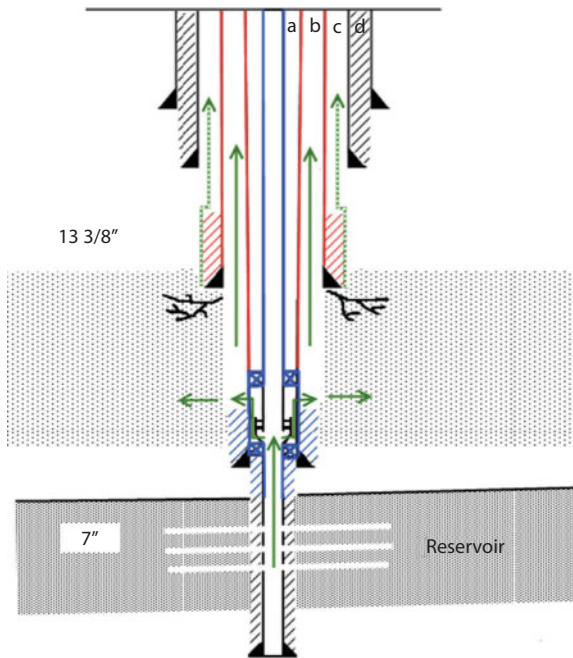

**Figure 7.15** Cement outside the 9 5/8 in. casing is set below the production packer.

*7.2.6.1 Case 1: Leak below Production Packer*

The 9 5/8 in. cement does not qualify as a primary barrier according to the requirements in the Norsok D-010 guideline. To qualify as a barrier TOC outside the 9 5/8 in. casing should be above the production packer. This defect occurred relatively frequently in older wells. The SCP in annulus “b” and possibly in annulus “c” shown in Figure 7.15 takes place because of two

barrier element failures. The first failure takes place in the 7 in. liner while the second failure occurs in the 9 5/8 in.

A leak below the production packer may therefore lead to fluid flowing into the formation or SCP in annulus b and/or annulus c. Primary barrier is marked with blue and secondary barrier with red color (from Eikås, 2012).

If a leak occurs below the production packer, and the formation outside cannot withstand the pressure, the fluid may flow along the wellbore or into the formation and, in some instances, all the way to the surface. If fluid is allowed to flow along the 9 5/8 in. wellbore, SCP may build up in annulus b. Because annulus b is outside the secondary barrier envelope, SCP is very unfavorable here. A SCP situation may or may not occur in annulus c depending on the formation in which the 13 3/8 in. casing shoe is set and the cement quality. This scenario is more thoroughly described in Case 3.

**Proposed Solution:** If the cement had been set above the production packer as shown in Figure 7.16, the problem might have been eliminated assuming the cement provided an impermeable seal. Also if the 13 3/8 in.

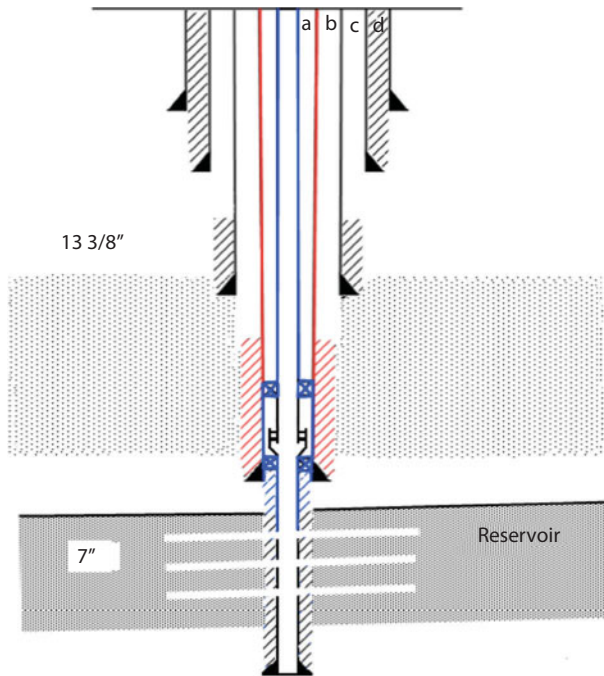

**Figure 7.16** Well cemented above production packer according to the Norsok standard D-010 (from Eikås, 2012).

casing and cement could have been redefined as a barrier, the SCP in annulus b would have been inside a barrier envelope and easier to control. The primary barrier is marked with blue and secondary barrier with red color as shown in Figure 7.16.

**Comparison:** Norsok D-010 has defined that the cement needs to be over the production packer to be valid as a barrier. If the packer not is covered by cement and the 13 3/8 in. casing cannot be redefined as a barrier, the well only has one valid barrier. According the Norsok standard there should always be at least two independent barrier envelopes in a well operation when a risk of uncontrolled outflow from the well to the external environment is present.

#### 7.2.6.2 Case 2: Casing Shoe above Unsealed High Pressure Formation

In Figure 7.17 a high pressure formation has to be drilled through to reach the reservoir. To be able to drill conventionally through the high pressure

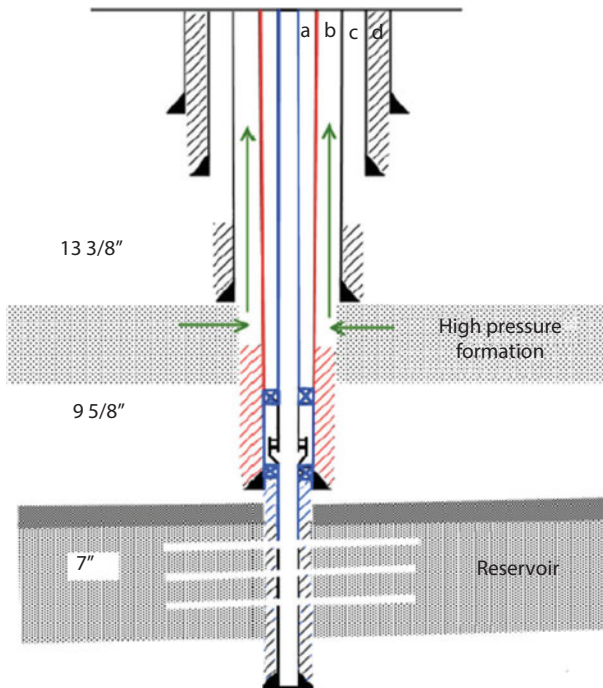
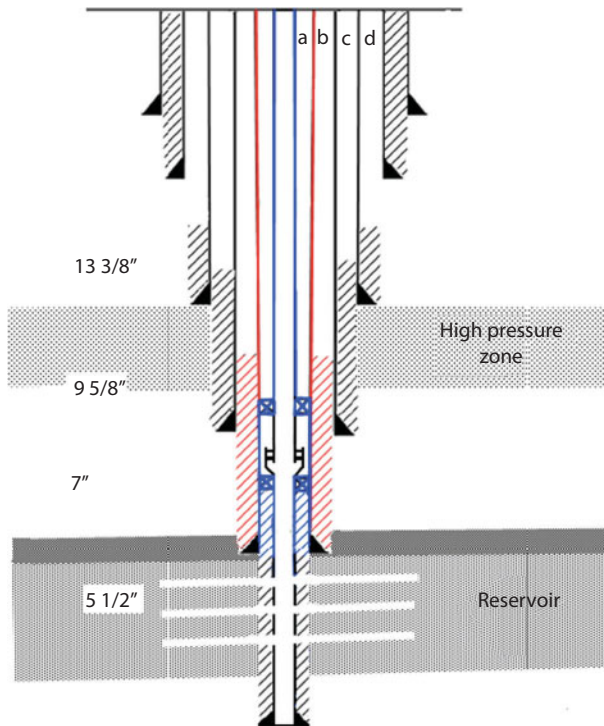

**Figure 7.17** Fluid from the high pressure zone enters the well causing pressure build up in annulus b (from Eikås, 2012).



formation, the 13 3/8 in. casing shoe was set just before entering the formation. The next casing was set at a depth that made it impossible to seal off the high pressure zone by cement. The result was an open hole section in the high pressure formation. Because the pore pressure in the high pressure formation exceeded the annulus fluid pressure, formation fluids were entering the wellbore creating SCP in annulus b. Primary barrier is marked with blue and secondary barrier with red color as shown in Figure 7.17.

**Proposed Solution:** To solve the problem with SCP arising in annulus b because of influx of formation fluids an extra casing may be used as shown in Figure 7.18. The 9 5/8 in. casing is set just below the high pressure formation instead of just above the reservoir. The new setting depth of the 9 5/8 in. casing makes it possible to seal off the high pressure formation. Since the 9 5/8 in. casing is set shallower a 7 in. production casing is set right



**Figure 7.18** The high pressure formation is properly sealed off preventing any inflow to the well (from Eikås, 2012).

above the reservoir. The production liner diameter is therefore reduced from 7 in. to 5 1/2 inches. This solution is in accordance with the recommendations from OLF – 117; “Formation zones which can give influx and pressure build up in annuli outside the established well barriers is often the most complex and challenging situations to manage and eliminate after SCP has occurred.” When the zone is properly isolated the drilling can be continued to the initially planned depth, but now with a smaller diameter. Primary barrier is marked with blue and secondary barrier with red color.

**Comparison:** It can be seen in Figure 7.17 that it was rather a lack of barriers than barrier failure that caused SCP. In Figure 7.18 it is shown how an extra casing string may be inserted enabling a proper seal off of the formation. It is more likely to get the high pressure formation properly sealed off when the height of the cement column is reduced. If the required seal off height is too large, the weight of the column might exceed the formation strength. In Figure 7.17 the required height was quite large. By inserting an extra casing string the required height is reduced and a successful seal off is more likely. In the proposal above an extra production casing of 7 in. was inserted leading to a reduction of the production liner diameter from 7 to 5 1/2 inches.

To avoid the reduction in production liner diameter it may have been possible to insert an 11 in. casing between the intermediate and production casing. If the casing strings are designed to withstand high pressure, the wall thickness will be quite large. The insertion of an extra casing string may therefore lead to a tight casing program. It may be harder to perform a good cement job in a tight annulus due to circulation rate.

If possible a different drilling method like dual gradient or MPD may have been used instead of inserting an additional casing. This may have allowed setting the 13 3/8 in. casing shoe below the high pressure formation and the production liner diameter would stay unchanged.

To use a different drilling method the previous set casing shoe must be able to withstand the pressure it may be exposed to in case of a leak.

To save steel the 9 5/8 in. intermediate casing may have been set as a liner as seen in Figure 7.19. A liner can be used instead of a casing string extending all the way to the surface if the previous casing string is designed any SCP that may occur. Primary barrier is marked with blue and secondary barrier with red color. If the burst resistance of a casing is increased, so is the wall thickness. A large diameter pipe needs a greater thickness than a small diameter pipe to resist the same amount of pressure. It may therefore be favorable to run the casing all the way to the surface instead of increasing the diameter of the previous casing string.

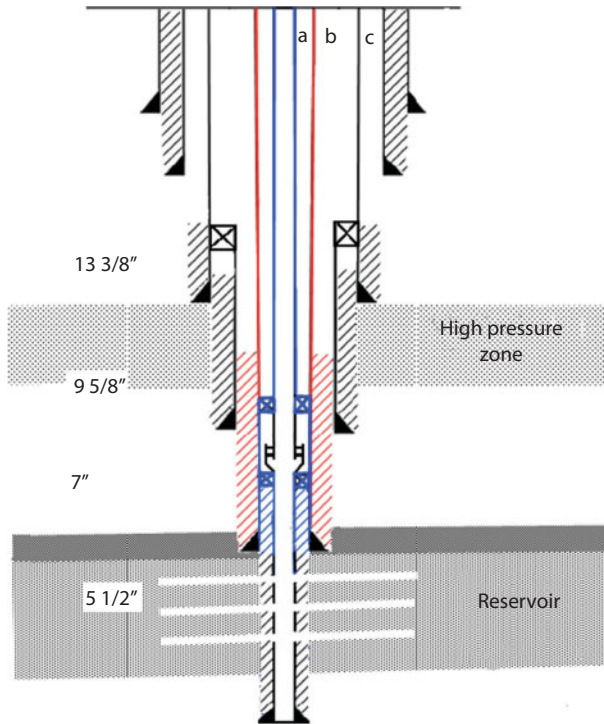

**Figure 7.19** The 9 5/8 in. casing is set as a liner instead of a casing going all the way to the surface (from Eikås, 2012).

### 7.2.6.3 Case 3: Casing Shoe set in Weak Formation

In Figure 7.20 a situation where two formations with different formation strength are located close to the setting depth of the 13 3/8 in. casing is shown. The 13 3/8 in. casing is set in the top formation i.e., the weakest formation of the two. During production a leak occurs in the production liner and in the 9 5/8 in. casing below the casing hanger packer. Reservoir fluid is allowed to flow and build up pressure in annulus b. The weak formation cannot withstand the reservoir pressure and fractures below the 13 3/8 in. casing shoe. Because of a bad formation/cement bond or channels in the cement fluid is allowed to flow into annulus c creating SCP here as well. If the leak occurs in other parts of the well, other sections of the well path may experience the same challenges. If the casing shoe and formation cannot handle the pressure of the leaked fluid, the shoe and surrounding formation cracks and fluid is allowed to enter the formation and/or migrate along the 13 3/8 in. casing into annulus c. Primary barrier is marked with blue and secondary barrier with red color.

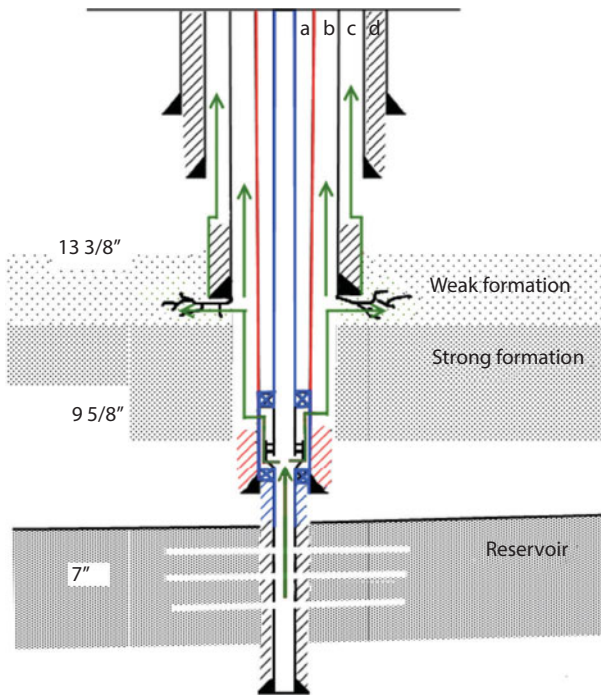

**Figure 7.20** 13 3/8 in. casing shoe is set in weak formation (from Eikås, 2012).

**Proposed Solution:** If the casing shoe can be set in different formations, OLF recommends setting the shoe in the formation that can withstand reservoir pressure. Assuming the strong formation could withstand reservoir pressure, the casing shoe should have been set there instead. By utilizing a different drilling method it may be possible to drill far enough so that the casing shoe can be set in the strong formation. An illustration of casing shoe set in the strong formation can be seen in Figure 7.21. 13 3/8 in. casing and cement can be redefined as a well barrier hence SCP can be monitored and controlled. Primary barrier is marked with blue and secondary barrier with red color.

If a more advanced drilling method does not enable deep enough drilling, an extra casing or liner may be applied. Setting the 13 3/8 in. casing shallower and adding an 11 in. casing may allow the 9 5/8 in. casing to be drilled deeper and set in the strong formation as shown in Figure 7.22. This arrangement can handle reservoir pressure. Here, primary barrier is marked with blue and secondary barrier with red color. Setting the shoe in the strong formation makes it possible to redefine the 13 3/8 in. casing and cement to a well barrier if required. The redefinition is possible because the

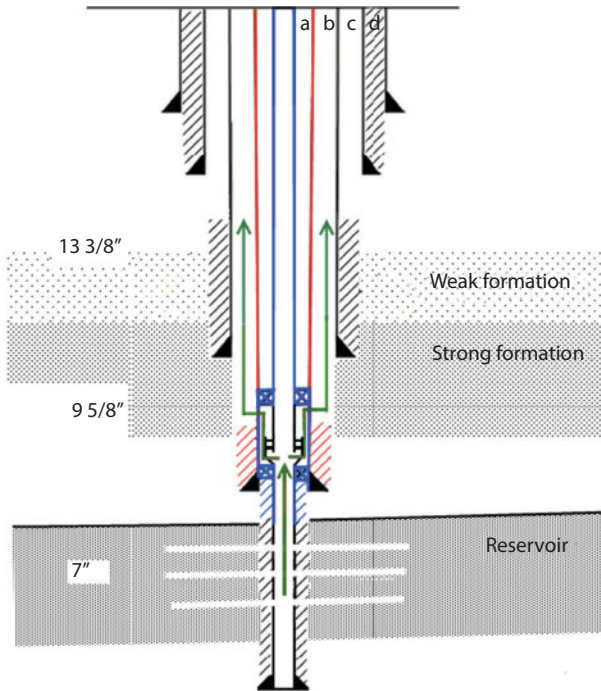

**Figure 7.21** Casing shoe set in the strong formation (from Eikås, 2012).

formation in the open hole section between the 9 5/8 in. cement and the 13 3/8 in. casing qualifies as a well barrier element.

**Comparison:** As mentioned in the discussion in case 2, to insert an extra casing in the casing program may involve challenges related to casing thickness and cementing. An option if further drilling or inserting the 11 in. casing is possible is to set a 9 5/8 in. casing at the planned 11 in. casing depth. A 7 in. production casing may be set above the reservoir and reduce the production liner diameter to 5 1/2.

#### 7.2.6.4 Case 4: Leak below Production Casing Shoe

If a leak occurs below the production casing shoe, it will not be restrained by the secondary barrier. This may be an extra unfortunate situation and should by all means be avoided. Figure 7.23 shows two possible origins of SCP. One leak has its origin directly from the reservoir along the 7 in. casing. The other leak originates in production liner and cement failure. The formation in which the 9 5/8 in. casing shoe is set in cannot withstand

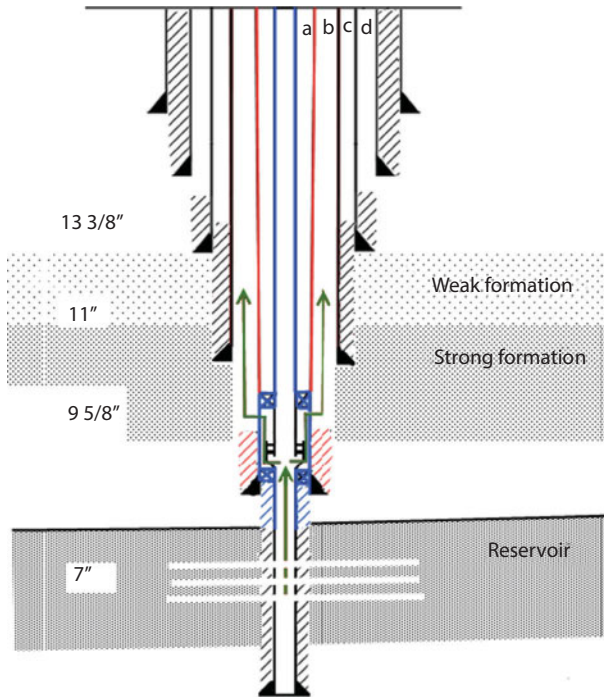
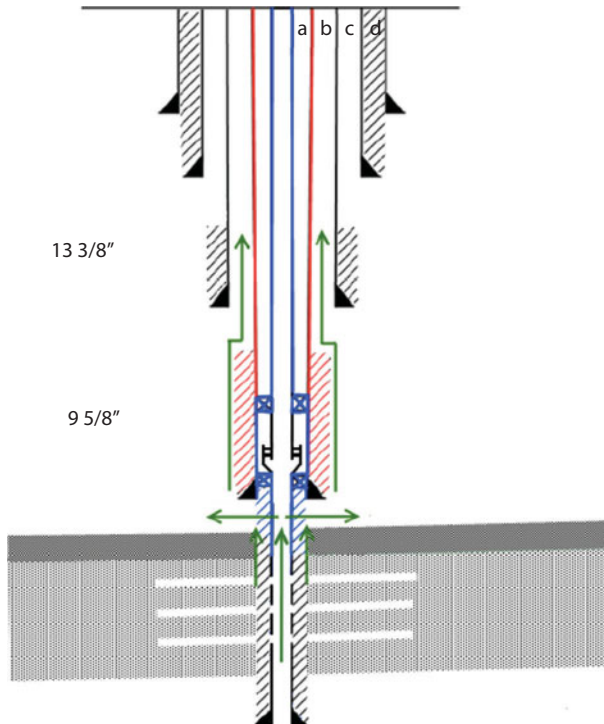

Figure 7.22 An additional 11 in. casing string (from Eikås, 2012).

reservoir pressure. Reservoir fluids are therefore allowed to flow into the formation and along the 9 5/8 in. cement into annulus b.

**Proposed Solution:** If it is found out that the formation strength at the chosen setting depth for the 9 5/8 in. casing not is sufficient to withstand reservoir pressure, the casing shoe needs to be set deeper (since formation strength usually is increasing with depth). If no part of the formation can take the pressure, the casing shoe may be set in the cap rock. The original 9 5/8 in. casing can be extended by using optional drilling methods or an additional casing string can be utilized. In Figure 7.24 it is shown how the 9 5/8 in. production casing is set in the cap rock to prevent fluids from escaping and crating SCP in annulus b.

Adding an extra casing string after the 9 5/8 in. casing may affect the liner diameter. Figure 7.25 shows how the liner diameter is reduced from 7 in. to 5 1/2 in. because a 7 in. production casing is inserted. Inserting an additional casing earlier in the drilling process may be an option that allows the production casing to be set deeper. It may also not affect the production liner diameter.

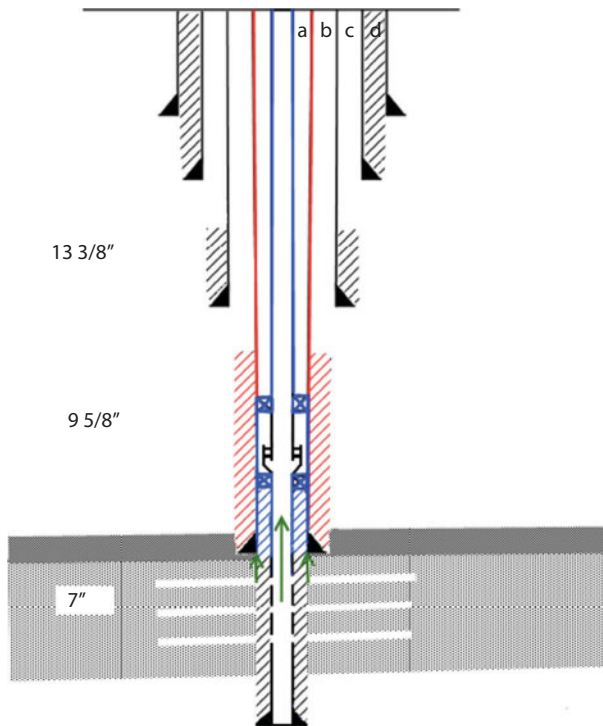

**Figure 7.23** Leak below liner hanger packer migrating into annulus a, b, and surrounding formation. Primary barrier is marked with blue and secondary barrier with red color (from Eikås, 2012).

**Comparison:** In the well planning phase the different formation strengths are supposed to be tested. If it is found out that the formation above the reservoir cannot withstand reservoir pressure, a casing planned to be set there should be reconsidered. If the leak path is directly from the reservoir along the 7 in. cement it may be hard to remove by redesigning the well. To remove this leak by setting the production casing in the caprock, the casing shoe has to be completely tight.

#### 7.2.6.5 Lessons Learned and Recommendations

When it comes to explaining how SCP arises, most research has its main focus on equipment failure, cement quality and cementing performance. Very little is done on the relation between casing shoe setting depth and SCP. The common practice today is often to drill a well with consideration to only situations that may arise during drilling. This study has tried to



**Figure 7.24** The 9 5/8 in. Casing is set deeper to extend the secondary barrier so that it protects leaks from below casing hanger packer. Primary barrier is marked with blue and secondary barrier with red color (from Eikås, 2012).

reveal whether the well would have been drilled differently if the production phase had been taken into consideration during the design phase.

Some factors contributing to the decision of casing shoe setting depth today are:

- Pore pressure
- Fracture gradient
- Protection of freshwater aquifers
- Lost circulations zones
- Salt beds and low pressure zones that may cause stuck pipe
- Kick criteria

These factors are important and should be considered to ensure a safe drilling operation. Since the well has more than one stage during its lifetime, factors that can contribute to improve the safety should also be



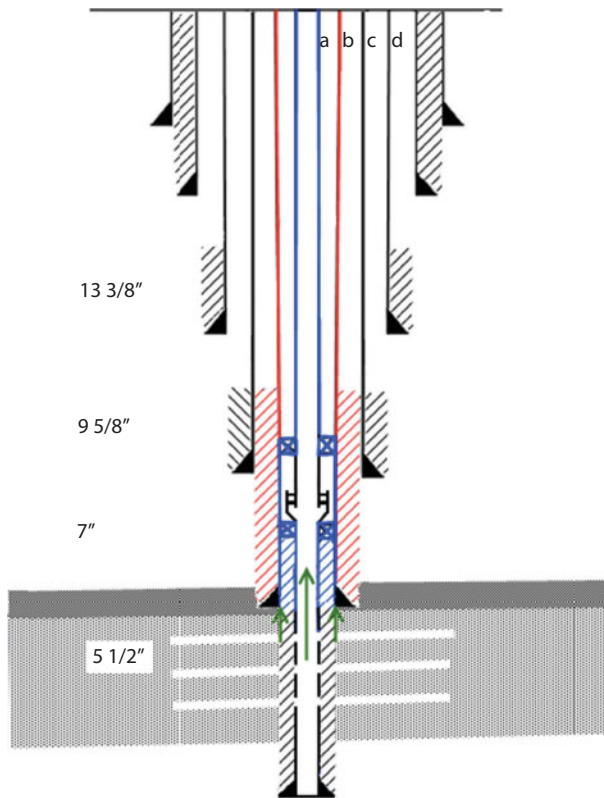
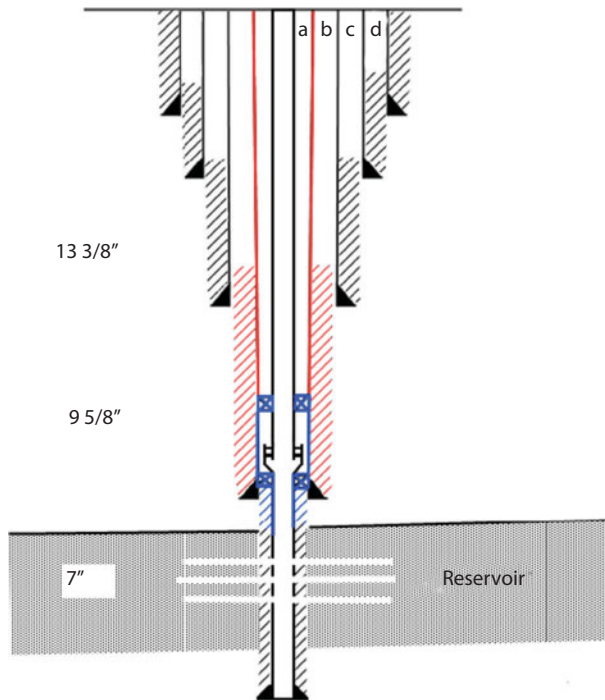

**Figure 7.25** A 7 in. production casing is added after the 9 5/8 in. to extend the secondary barrier so that it can prevent leaks from under the liner hanger packer to travel into annulus b and the surrounding formation. Primary barrier is marked with blue and secondary barrier with red color (from Eikås, 2012).

implemented during well planning and design. Some important factors that are advantageous during the production phase are:

- Possible to redefine barriers
- Set shoe in strong formation so that it can withstand situations with high pressure
- Avoid open hole sections in high pressure and high permeable formation cementing

Many SCP situations that occur because of fluid migration between casing layers is a result of bad conversion between TOC and the previous casing shoe setting depth. If the cement column had been higher, or the casing shoe had been set deeper, many SCP situations may have been avoided.



**Figure 7.26** Well design preventing inflow from surrounding formation into annulus if the cement is perfect without channels and the cement-formation/casing bond is good etc. Primary barrier is marked with blue and secondary barrier with red color (from Eikås, 2012).

If the well had been completed with completely overlapping between all cement columns and casing strings, the problem with SCP related to casing shoe setting depth might have been avoided. Figure 7.26 shows a well design where inflow into annulus from surrounding formations is prevented by overlapping between cement and previous casing strings. This assumes that the cement sheet is flawless hence no channels, good cement formation/casing bond, etc. As previously discussed the chance of a perfect cement seal is very small.

It is not common practice to have overlapping sections between cement and casing strings in all parts of the well. This may be due to:

- Cement expenses and complications related to obtaining a good cement sheet when cementing over large intervals.
- Much easier to do a sidetrack in an open hole than in a cemented section.

- Sometimes it may be better that excessive pressure has the opportunity to flow into the formation rather than building up inside the annulus threatening to break casing strings and in worst case the wellhead causing a blowout.

There may be several different reasons why the cement is not satisfying the criterion. It may be:

- The required height of the cement column creates too large pressure on the formation surrounding the casing shoe
- Annulus may be too tight, not possible to squeeze cement into the small space
- Cement may break down the formation

A solution on how to get the cement column high enough is to use squeeze cementing. The bottom part is cemented first, then the casing can be perforated at TOC and the next section is cemented. One of the disadvantages related to squeeze cementing is that the perforated casing creates a possible leak path. SCP is often a result of poor correlation between casing shoe setting depth and TOC. This means that eliminating the deficiency in one of them may remove SCP. Deficiency for casing shoe setting depth may include, but is not limited to:

- Casing is not set deep enough
- Casing is not designed to withstand the pressure it may be exposed to
- Casing may be set in a formation that cannot withstand high pressure
- Cement deficiency due to column not being high enough as required by the Norsok standard
- Cement deficiency due to the prevalence of poor sealing in high pressure zones or weak formations.

### 7.2.7 Case Study – 7 (Surface Casing Setting)

Baron and Skarstol (1994) presented a number of case studies. A new technique for optimizing surface casing depth was tested against a number of field cases. This new method was inspired by a set of new regulation changes in Alberta on surface casing setting. The depths determined with the new method compare favorably with the depths currently used by industry.

The optimum setting depth for surface casing can only be determined with an understanding of why surface casing is set. The first task is to determine what is the primary purpose of the casing. Is the primary function of surface casing to protect aquifers, to provide hole stability, to allow a kick to be circulated out, to or allow the well to be completely shut-in after a kick has been detected?

The primary function of surface casings is to allow a kick to be circulated safely out of a well. The new requirements in Alberta should ensure that fracturing to surface is prevented by the ability of the formation at the surface casing shoe to tolerate kick pressures during the driller's method of well control. For shallow wells (<1,000 m), the low-choke method of well control should continue to be used (Alberta Rules, 2018).

### 7.2.7.1 Leak-off Tests

Other methods of picking the optimum casing point have concentrated mainly on determining the formation fracture or leak-off gradient. However, the formation leak-off gradients cannot be predicted with any reasonable certainty. Although leak-off testing procedures are crude and can lead to variations in data, they will generally yield a reasonable minimum leak-off gradient for a given well. Leak-off gradients from a given well cannot be applied to adjacent wells because of the wide range in results. Figure 7.27 shows the severe scatter of leak-off gradient data from a sample area in Alberta.

Approximately 75% of the data points in Figure 7.29 are above 22 kPa/m. The 22 kPa/m value approximates the average overburden gradient in most areas. Thus, a competent zone is defined as having a leak-off gradient

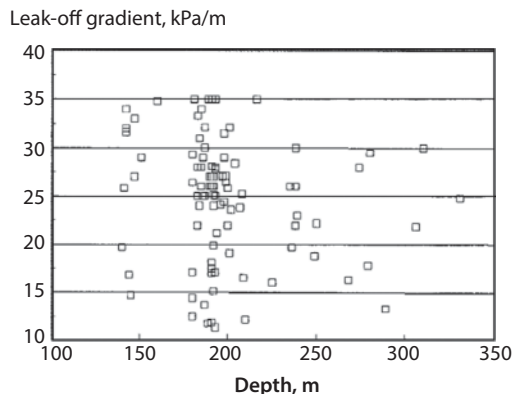

Figure 7.27 Variability of leak-off test results (From Baron and Skarstol, 1994).

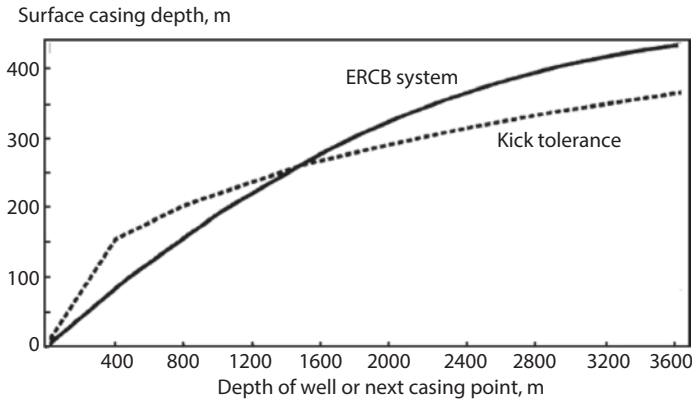

Figure 7.28 Surface casing depth selection (From Baron and Skarstol, 1994).

of at least 22 kPa/m. If more emphasis were placed on choosing a competent zone for the casing seat, the number could approach 100%. It is recommended that 22 kPa/m be used as the formation leak-off gradient in the kick tolerance equation.

If a competent zone were defined by a minimum formation leak-off gradient, there would be no need to use theoretical methods to determine fracture gradient. Instead, individual well leak-off testing would be necessary to ensure that the minimum is met.

If a leak-off test determines that the gradient is less than the minimum, then the driller's method of well control may result in casing pressure exceeding the maximum allowable casing pressure (MACP). An acceptable alternative method, such as the low-choke method should then be used.

Figure 7.28 shows the results from using the kick tolerance equation, assuming a 3 cu m pit gain or initial kick volume. The kick tolerance equation yields surface casing depths in the range of 10–30% of total depth. These values compare favorably to the depths currently used by industry as dictated by regulators.

The new system uses the ERCB's previous curve which was based on a formation fracture gradient of 22 kPa/m at the surface casing shoe and a reservoir pressure gradient of 10 kPa/m. The built-in assumption in the curve was that 27.5% of the reservoir pressure must be held at the surface casing shoe for wells drilled to 3,600 m. This percentage increases linearly to 50% of reservoir pressure for a theoretical zero well depth.

The changes included a system that modifies the curve by allowing the use of reservoir pressure gradients greater or less than 10 kPa/m (Figure 7.29). In the decision to retain this part of its requirements, the ERCB compared

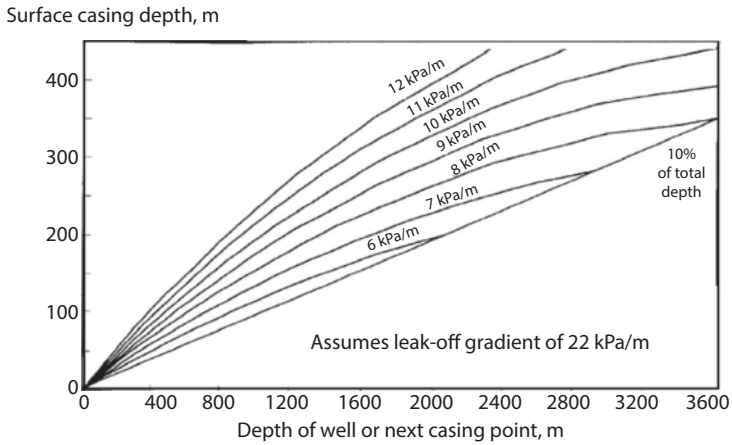

Figure 7.29 ERCB Surface casing requirements (From Baron and Skarstol, 1994).

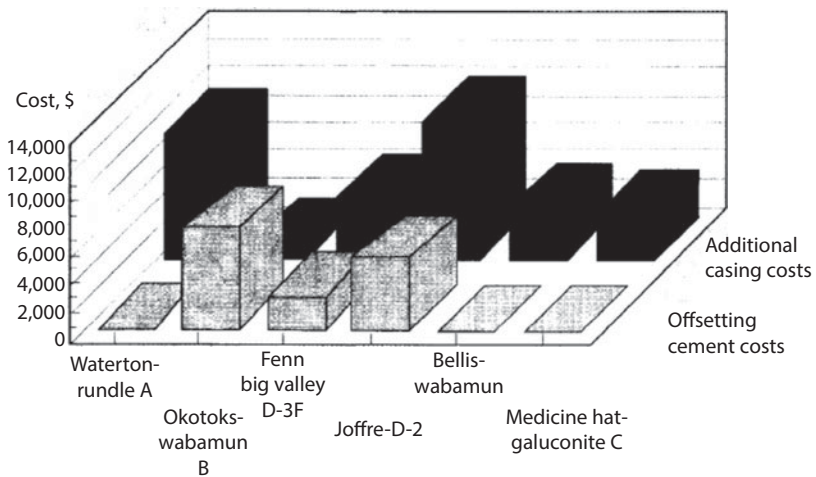

Figure 7.30 Surface casing and long string cement cost (From Baron and Skarstol, 1994).

its curve to results from the kick tolerance method (assuming an initial kick volume of 3 m<sup>3</sup>).

The ERCB's curve yields less surface casing than the kick tolerance method for wells less than 500 m in depth and more surface casing for wells in the 1,500–3,600 m depth range (Figure 7.30). Overall, the comparison is fairly close, and the justification for retaining the curve is that the low-choke method of well control has been successfully used in Alberta's shallow wells. The use of the low-choke method allows less surface casing

than the driller's method because casing pressure is deliberately held just below the ACP. In the driller's method, casing pressure is allowed to rise to the MACP and then fall.

The low-choke method can require numerous circulations before the influx can be completely circulated out of the wellbore. By comparison, the driller's method theoretically requires only one circulation to remove a kick from the well bore. Thus, the low-choke method is not desirable in deeper wells because of the large volume of fluid to be circulated. Many circulations may be needed, increasing the risk of failure in the bleed-off system.

The margin of safety gained by requiring deeper wells to have more surface casing than calculated by the kick tolerance equation is justified because actual leak-off tests may yield a formation fracture gradient less than 22 kPa/m.

#### 7.2.7.2 Reduction System

The second draft of the ERCB's guide included a reduction system that allowed for less surface casing than determined by the system shown in Figure 7.29. The reduction system is based on well control.

The oil industry considered the 3 m<sup>3</sup> initial kick volume, used in the kick tolerance method, to be too high. The argument was that kick volumes could be limited to 1.5–2.5 m<sup>3</sup> where electronic pit volume totalizer (PVT) systems were in use.

It is generally understood that 5–8 m<sup>3</sup> (30–50 bbl) is a reasonable estimate for conditions frequently encountered. According to Aadnoy, *et al.* (1991), 5 m<sup>3</sup> is a typical detectable kick volume. The ERCB agrees with industry that recent advances in technology should allow earlier detection of kicks. Thus, for casing design, the detectable kick size can be limited to less than 3 cu m. Based on the kick tolerance method, the surface casing depth is proportional to the square root of initial kick volume. The ERCB reduction system uses the square root of kick volume in determining reduction factors as follows:

- If a PVT system is installed on a well and sounds an alarm at 2.0 m<sup>3</sup>, the kick volume can be limited to 2.5 m<sup>3</sup>. Therefore, a reduction factor of  $(2.5 \text{ m}^3/3.0 \text{ m}^3)^{1/2} = 0.91$  can be applied to the surface casing determined by the base system in Figure 7.29.
- If a PVT system is installed on a well and sounds an alarm at 1.0 m<sup>3</sup>, the kick volume can be limited to 1.5 m<sup>3</sup>. Therefore, a reduction factor of  $(1.5 \text{ m}^3/3.0 \text{ m}^3)^{1/2} = 0.71$  can be applied to the surface casing determined by the base system.

The first tier reduction factor of 0.91 can be applied to the surface casing depth determined for any well proving the PVT is installed, or a leak-off test is conducted.

The second tier reduction factor of 0.71 can only be applied to low-risk development wells. A low-risk well is defined as a well drilled in a field where the kick rate is less than 3 kicks per 100 development wells drilled. The reasoning is that the substantial 30% reduction in surface casing setting depth should be applied only where there is a high degree of confidence, that is, where reservoir pressure and other data are well known and where the risk of taking a kick is small.

The third tier reduction included in the ERCB's guide is for locations where surface casing may be reduced to the historical setting depth. This reduction can result in surface casing set as shallow as 5% of planned total depth, which is insufficient to circulate a kick using the driller's method.

Because the low-choke method must be used where there is a high risk of a failure in the bleed-off system for deep wells, the ERCB requires an emergency flare line to be installed. In addition, because the low-choke method relies heavily on the MACP value, a leak-off test is mandatory. Finally, this type of reduction can only be applied to low-risk development wells that use a PVT system that sends an alarm for a 1.0 cu m kick.

Accurate determination of the leak-off pressure is essential during well control. Although leak-off tests are only mandatory for wells with reductions to historical setting depth, the ERCB strongly encourages leak-off testing on all other wells to ensure accurate determination of leak-off pressures.

The regulations in Alberta stipulate that all useable aquifers must be covered by either a cement sheath or surface casing. In many cases the surface casing setting depth is not deep enough to cover all useable aquifers, and therefore the next casing string must be cemented full-length or staged to ensure aquifer coverage.

The new regulations in Alberta have resulted in deeper surface casing for some areas, increasing the potential for aquifer coverage by the surface casing. In pools where the deeper surface casing covers the aquifer, the cement top requirement for the next string has often been lower.

Prior to any changes in the surface casing requirements, a study tried to determine if there would be some offsetting cost savings in cementing. Six pools with depths from 700 to 3,600 m in central and southern Alberta were selected at random (Table 7.7). Pools in northern Alberta were not selected because of a limited amount of aquifer data.

Figure 7.30 shows the additional surface casing costs (\$70/m, which includes surface casing and additional surface hole cost) that would be incurred under the new system for the six pools. The approximate offsetting



**Table 7.7** Cost study area

Field	Depth, m	Existing system, m	New system, m	Required cement top, m	Deepest useable aquifer, m
Waterton	3600	360	490	1200	600
Okotok	2700	365	375	950	350
Fenn Big Valley	1650	165	230	300	180
Joffre	2080	210	355	650	233
Bellis	700	70	125	390	115
Medicine Hat	825	125	175	0	123

cementing costs include \$1,500 for fixed costs, \$10.50/m for cement, and \$2.00/m for cement service (These costs are book prices and therefore a 40% discount was applied).

In three of the pools, the deeper surface casing covered the useable aquifers, thereby reducing the long string cementing costs. Figure 7.31 shows the overall cost changes because of the new system.

In five of the pools, the overall effect is an additional capital outlay averaging \$4,000 and ranging from \$2,000 to \$9,000. The Okotoks-Wabamun B pool, however, had a net decrease in costs as a result of surface casing aquifer coverage. In this example, the additional surface casing costs were completely offset by lower cementing costs.

The three-tier reduction system may also help offset the increased costs. For tier one, a 10% reduction in surface casing costs can be realized for any well where a PVT system with a 2 cu m alarm is used or where a leak-off test is conducted. For many years, the deeper wells drilled in Alberta have used rigs equipped with PVT systems. Thus, the 10% savings in surface casing can be realized without incurring additional cost.

For shallower wells, the cost of renting a PVT system can be offset by the surface casing reduction (PVT rental for 10 days is approximately \$2,500, and the cost is approximately offset by a 20-m reduction in surface casing setting depth, at \$70/m).

The tier two reduction for low risk development wells can decrease surface casing costs by 30%. Wells eligible for the tier-three reduction may have the setting depth requirement revert back to the historical depth, resulting in no increase in surface casing costs (the Harmattan East-Rundle pool, for example).

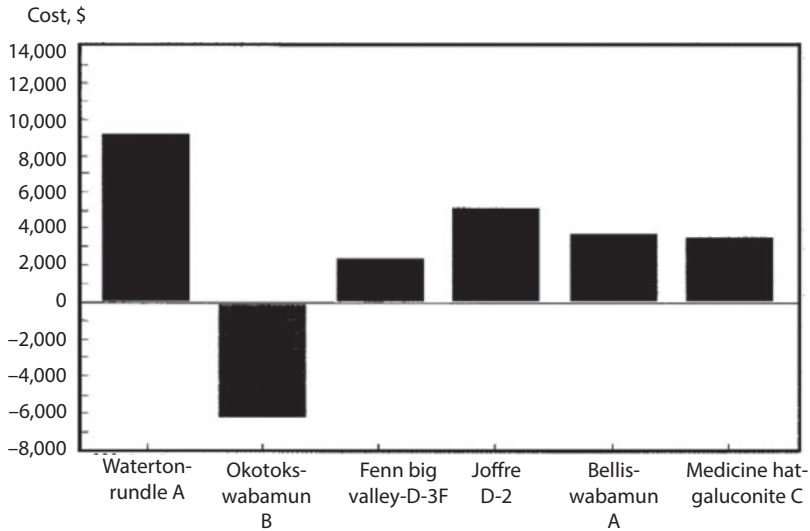

Figure 7.31 Change in net cost.

In general, the changes were expected to result in slightly increased costs to industry. In areas where full-length cementing of the next casing string was already required or in areas such as the foothills where deep useable aquifers exist, the potential for offsetting cementing costs is low. In other areas, such as south-central Alberta, however, there is potential for lower cementing costs to partially offset increased surface casing costs. Furthermore, the three-tier reduction system may also offer some cost relief in areas where it is applicable.

### 7.3 Summary

In this chapter, various problems associated to casing drilling or workovers related to casing damages or malfunctions are presented. Best industry practices are mentioned for remedying each problem. A number of case studies are presented, carefully selected from a diverse array of applications, albeit all related to casing problems.

### References

Aadnoy, B.S. 2010. *Modern Well Design*, second edition, Leiden, The Netherlands: CRC Press/balkema, ISBN 978-0-415-88467-9

- Aadnoy, B.S., Soteland, T., Ellingsen, B., 1991, Casing point selection at shallow depth, *Journal of Petroleum Science and Engineering*, Volume 6, Issue 1, July 1991, pp. 45–55.
- Adams, N., 1980, *Well Control Problems and Solutions*, Petroleum Publishing Co., 1980.
- Addis, M. A., Hanssen, T. H., Yassir, N., Willoughby, D. R. *et al.* 1998. A Comparison Of Leak-
- Alberta Rules, 2018, [http://www.qp.alberta.ca/documents/Regs/1971\\_151.pdf](http://www.qp.alberta.ca/documents/Regs/1971_151.pdf) accessed Jan. 13, 2018.
- Alliquander, O., *Design Methods of Setting Protecting Casing String in Hungary*, American Institute of Mining Metallurgical and Petroleum Engineers, 1974.
- Anonymous, 2012, Casing Problem in Drilling, *Drilling Today*, Nov. 13.
- Bachu S, Watson TL. Review of failures for wells used for CO<sub>2</sub> and acid gas injection in Alberta, Canada. *Energy Procedia*. 2009;1:3531–3537.
- Bailey, B. *et al.* “Water Control,” *Oilfield Review* 12 (Spring 2000) 30–51.
- Baron, S. and Skarstol, S., 1994, New method determines optimum surface casing depth, *Oil & Gas Journal*; Tulsa Vol. 92, Iss. 6, (Feb 7, 1994): 51.
- BCPRB, 1991, British Columbia Petroleum Resources Branch, “Drilling and Production Regulations,” 1991.
- Begos K. 2014. Some states confirm water pollution from drilling. Associated Press. Available at <http://bigstory.ap.org/article/some-states-confirm-water-pollution-drilling>. Accessed Jan 7, 2018.
- Bellabarba, M., Bulte-Loyer, H., Froelich, B. *et al.* 2008. Ensuring Zonal Isolation beyond the Life of the Well
- Bonett, A., Pafitis, D. 1996. *Getting to the Root of Gas Migration*.
- Bourgoyne, A.T. Jr., Chnevert, M.E. and Millheim, K.K. *et al.* 1986. Applied Drilling Engineering, Vol. 2, 330–339. Richardson, Texas: Textbook series, SPE
- Bourgoyne, A.T. Jr., Scott, S.L. and Manowski, W. 1999. A Review of Sustained Casing Pressure Occurring on the OCS. Technical Report Contract Number 14-35-001-30749, Louisiana State University, Louisiana (24–25 March)
- Brufatto C, *et al.* From mud to cement—Building gas wells. *Oilfield Review*. 2003;15:62–76.
- Carey J.W. Geochemistry of wellbore integrity in CO<sub>2</sub> sequestration: Portland cement-steel-brine-CO<sub>2</sub> interactions. *Rev Mineral Geochem*. 2013;77:505–539.
- Christman, S.A. 1976. Casing Stresses Caused by Buckling of Concentric Pipes. Presented at the SPE Annual Fall Technical Conference and Exhibition, New Orleans, Louisiana, USA, 3–6 October. SPE-6059-MS. <https://doi.org/10.2118/6059-ms>.
- Clark, C.E. and Veil, J.A., 2009, Produced Water Volumes and Management Practices in the United States, DoE Report, Argonne National Laboratory.
- Considine TJ, Watson RW, Considine NB, Martin JP. Environmental regulation and compliance of Marcellus Shale gas drilling. *Environ Geosci*. 2013;20-1:16.
- Davies RJ, *et al.* Oil and gas wells and their integrity: Implications for shale and unconventional resource exploitation. *Mar Pet Geol*. 2014 doi: 10.1016/j.marpetgeo.2014.03.001.

- Davies RJ, *et al.*, 2014, Oil and gas wells and their integrity: Implications for shale and unconventional resource exploitation. *Mar Pet Geol.* 2014 doi:10.1016/j.marpetgeo.2014.03.001.
- Dawson, R. 1984. Drill Pipe Buckling in Inclined Holes. *J Pet Tech* 36 (10): 1734–1738. SPE-11167-PA. <https://doi.org/10.2118/11167-pa>.
- Driscoll, F., 1986, *Groundwater and Wells*, St. Paul: Johnson Division, submitted as NRC015, Aug. 25, 2014.
- Eikås, Inger Kamilla, 2012, Influence of Casing Shoe Depth on Sustained Casing Pressure, MSc Thesis, Department of Petroleum Engineering and Applied Geophysics, Norwegian University of Science and Technology.
- ERCB, 1986, Energy Resources Conservation Board of Alberta, “Minimum Surface Casing Requirements and Exemptions --ERCB Guide G-8,” 1986.
- ERCB, 1990, Energy Resources Conservation Board of Alberta, “Oil and Gas Conservation Regulations,” AR19/90.
- Erno B, Schmitz R. Measurements of soil gas migration around oil and gas wells in the Lloydminster area. *J Canadian Petroleum Technol.* 1996;35:37–45.
- Frequency of inspections, The Pennsylvania Code, Chapter 78, Subchapter X, Sect. 78.903 (2001)
- Government Accountability Office 1989. Drinking Water: Safeguards Are Not Preventing Contamination From Injected Oil and Gas Wastes, GAO-RCED-89-97. Available at [www.gao.gov/products/RCED-89-97](http://www.gao.gov/products/RCED-89-97).
- Ifeanyi1, N.R., Francis, A., and Tsokwa, T., 2017, Predicting Drillstring Buckling, *American Journal of Engineering Research (AJER)*, Volume-6, Issue-5, pp 301–311.
- Ingraffea AR, Wells MT, Santoro RL, Shonkoff SBC. Assessment and risk analysis of casing and cement impairment in oil and gas wells in Pennsylvania, 2000–2012. *Proc Natl Acad Sci USA.* 2014, 111, 10955–10960.
- IOGCC, 1992, Interstate Oil and Gas Compact Commission, “Summary of State Statutes and Regulations for Oil and Gas Production,” 1992.
- Islam, M.R., 1993, “Oil Recovery from Bottomwater Reservoirs”, *J. Pet. Tech.*, Technology Today Series, June, 514–516.
- Jackson, R.B., 2014, The integrity of oil and gas wells, *Proc Natl Acad Sci U S A.* 2014 Jul 29; 111(30): 10902–10903.
- Jurinak, J., & Summers, L. (1991), Oilfield applications of colloidal silica gel. *SPE Production Engineering*, 6(4), 406–412.
- Kang M. 2014. CO<sub>2</sub>, methane, and brine leakage through subsurface pathways: Exploring modeling, measurement, and policy options. PhD dissertation (Princeton Univ, Princeton)
- Khosravanian, R. and Aadnoy, B.S., 2016, Optimization of casing string placement in the presence of geological uncertainty in oil wells: Offshore oilfield case studies, *J. Pet. Sci. Eng.*, vol. 142, 141–151.
- King GE, King DE. Environmental risk arising from well construction failure—Differences between barrier failure and well failure, and estimates of failure frequency across common well types, locations and well age. *SPE Production and Operations.* 2013;28:323–344.

- Li, C., and Samuel, R., 2017, Buckling of Concentric String Pipe-in-Pipe, SPE-187455, presented at SPE Annual Technical Conference and Exhibition, 9–11 October, San Antonio, Texas, USA.
- Lubinski, A. 1950. A Study of the Buckling of Rotary Drilling Strings. In *Drilling and Production Practice*. Washington, DC: American Petroleum Institute.
- Lubinski, A. and Althouse, W.S. 1962. Helical Buckling of Tubing Sealed in Packers. *J Pet Tech* 14 (06): 655–670. SPE-178-PA. <https://doi.org/10.2118/178-pa>.
- Marca, C.: “Remedial Cementing” in *Well Cementing, Developments in Petroleum Science* 28 (1990), E.B. Nelson, ed., Elsevier, Amsterdam, 13–1.
- MiReCOL, 2017, Overview of available well leakage remediation technologies and methods in oil and gas industry, Project no. Project no.: 608608, final report.
- Mitchell, R.F. 1982. Buckling Behavior of Well Tubing: The Packer Effect. *SPE J* 22 (05): 616–624. SPE-9264-PA. <https://doi.org/10.2118/9264-pa>.
- Miyazaki B. Well integrity: An overlooked source of risk and liability for underground natural gas storage: Lessons learned from incidents in the USA. *Geol Soc Lond Spec Publ.* 2009;313:163–172
- Nicot JP, Scanlon BR. Water use for Shale-gas production in Texas, *U.S. Environ Sci Technol.* 2012;46(6):3580–3586.
- Norsok standard D-010 *Well integrity in drilling and well operations*, third edition. 2004.
- O&G Journal*, 1990, patches cure leaky casing problems in Indonesia, May 28.
- Off Test And Extended Leak-Off Test Data For Stress Estimation. Paper SPE/ISRM 47235, presented at the SPE/ISRM Eurock '98, Trondheim, Norway, 8–10 July.
- Paslay, P.R. and Bogy, D.B. 1964. The Stability of a Circular Rod Laterally Constrained to Be in Contact with an Inclined Circular Cylinder. *Journal of Applied Mechanics* 31 (4): 605–610.
- RCT, 1992, Railroad Commission of Texas, “Statewide Rules for Oil, Gas, and Geothermal Operations,” Oil and Gas Division, 1992.
- SCDC, 1988, State of California Department of Conservation, “California Code of Regulations,” Title 14, Register 88, No. 22-5-28-88.
- Schlumberger, Oilfield Glossary, ID: 1464 , <http://www.glossary.oilfield.slb.com/Display.cfm?Term=liner> (accessed 26 May 2012).
- SEM, 1991, Saskatchewan Energy and Mines, “Oil and Gas Conservation Regulations,” 1992.
- Seright, R.S., 1993, “Effect of Rock Permeability on Gel Performance in Fluid-Diversion Applications,” *In Situ*, 17(4), 363–386.
- Seright, R.S., Lane, R.H., Sydansk, R.D., 2003, A Strategy for Attacking Excess Water Production, *SPE Production & Facilities*, August, 158–169.
- Shen, Z., 2012, Numerical Modeling of Cased-Hole Instability in High Pressure and High Temperature Wells, PhD Dissertation, Texas A&M University.
- Tancret, F. *et al.*, 2003, Design of a creep resistant nickel base superalloy for power plant applications Part 3–Experimental results, *Materials Science and Technology*, March, Vol. 19, 296–302.

- Vengosh A, *et al.* A critical review of the risks to water resources from unconventional shale gas development and hydraulic fracturing in the United States. *Environ Sci Technol.* 2014 doi: 10.1021/es405118y.
- Vidic RD, Brantley SL, Vandenbossche JM, Yoxtheimer D, Abad JD. Impact of shale gas development on regional water quality. *Science.* 2013, 340 (6134):1235009.
- Vignes, B. and Aadnoy, B.S. 2008. Well-Integrity Issues Offshore Norway. Paper SPE/IADC 112535 presented at the SPE/IADC Drilling Conference, Orlando, Florida, 4–6 March.
- Vignes, B., Andreassen, J. and Tønning, S.A. 2006. PSA Well Integrity Survey, Phase 1 summary report. Petroleum Safety Authority Norway, Norway (30 June 2006).
- Watson TL, Bachu S., 2009, Evaluation of the potential for gas and CO<sub>2</sub> leakage along wellbores. *SPE Drill & Compl.*, 24:115–126.
- Wojtanowicz, A. K., Nishikawa, S. and Rong, X 2001. Diagnosis and Remediation of Sustained Casing Pressure in Wells. Technical Report, Louisiana State University, Baton Rouge, Louisiana, 31 July

# 8

## Cementing Problems

### 8.0 Introduction

Even though cementing technology has been in existence throughout human civilization, artificial cementing technology that processes limestone at a very high temperature to produce inorganic cement is in sync with the plastic era. Portland cement, which originates from limestone, was developed in the mid-19<sup>th</sup> century in England. However, the first patent on that technology came out in 1822, albeit with the name “British cement” (Francis, 1977). When Halliburton received its patent for a “Method and Means for Cementing Oil Wells,” it helped revolutionize industry practices of well completion. For the first time, cement was being proposed to be used without any other material, such as sand or concrete. Since the introduction of Portland cements for the construction of oil and gas wells in the 1920s, cementing has become one of the essential phases in drilling operations and in the maintenance of production wells. Halliburton’s patent (No. 1,369,891, approved on March 1, 1921) identified the role of cementing the annulus, i.e., prevent water intrusion that diminishes oil productivity and leads to premature abandonment of many wells. It turns out that most

of the functions of a casing cannot be maintained unless the cementing of the annulus is in good condition. More importantly, none of the safety measures can survive a failed cement job. For instance, BOP operations, mud loss, collapse of casing, and well integrity are all related to functionality of the cementing job. If the primary barrier is the inner envelope surrounding the well bore, then the secondary well barrier is the envelope that closes around both the primary barrier and the well bore. This happens to be linked to the quality of a cement job. To strengthen the well and protect the environment, cement is pumped down the surface casing to fill the space between the outside of the casing and the well bore all the way to the surface. The casing and the cement typically are tested under pressure for 12 hours before drilling operations can resume. A vital piece of equipment for controlling pressure – the blowout preventer – is attached at the top of the surface casing. This ensures the protection of freshwater aquifers and the security of the surface casing. It is only after the placement of the surface casing and its cementation that the BOP Unit is installed at the wellhead.

Cementing job as such remains a challenging one because each cementing operation must be designed based on local conditions with their unique geological environment. It is commonly recognized that (i) there is no single fit-for-purpose design, well construction, or barrier verification process that is right for all wells, (ii) the barrier system that protects usable water includes surface casing and cement, (iii) verification of the effective isolation is typically accomplished by both pressure testing (direct measurements of casing and shoe cement) and by an operational evaluation (cement placement behind tubular), and (iv) there is no direct measurement available to verify a cement barrier behind casing at present.

## **8.1 Problems Related to Cementing and their Solutions**

The petroleum well cementing process involves mixing cement powder with water and a number of additives to prepare cement slurry and placing the slurry into the annular space between the casing and the wellbore. The additives usually are selected in order to address the specific need of the annulus being isolated. Often, the additives also dictate the setting period of the cement slurry – a period during which cement dehydrates and the compressive strength rises rapidly. Simultaneously, the cement permeability drops drastically. This is also the time any fissure within the cement body develops that might have a long-term effect on the casing integrity.



The wells are drilled in stages with smaller diameter being drilled as deeper formation is reached. Each stage has to have its own casing and cementation of the annulus. Until cementing of a given casing is completed, cement set, and casing integrity tested, further drilling cannot proceed. It is, therefore, extremely important to maintain best cementing practices throughout the drilling operation. Even during the production phase, cementing is used most commonly to permanently shut off water influx into the well. At the end of the well life when production is no longer economical, cementing prepares the well for abandonment.

Numerous factors affect a cementing job. They all play a role and can lead to cementing problems if not considered adequately. These factors are summarized as (i) condition of the drilling fluid, (ii) use of spacers and flushes, (iii) movement and rotation of the pipe, (iv) centralizing the casing, (v) the displacement rate, (vi) slurry design vis à vis prevailing temperature and pressure conditions, (vii) cement composition, and (viii) cement slurry volume and the volume of the spacer fluid.

### 8.1.1 Leaks due to Cement Failure

The principal objective of cementing is to provide an impermeable, zonal isolating sheet that is supposed to last throughout the lifetime of the well (Bellabarba *et al.*, 2008). Cement failure can occur for many reasons. The cement may become brittle and may not respond very well to pressure and temperature induced loads.

During the process of cement setting, it goes from the liquid slurry form to final solid form through a series of exothermic reaction that alters the prevailing temperature significantly. Because many parameters contribute to the cement setting process, each of which is affected by the temperature, the probability of a defect is quite high. The cement is set in a liquid form until it obtains its final condition as a solid. It goes through different phases. During this process there are many parameters contributing that may lead to defects in the cement (Bourgoyne *et al.*, 1986).

Figure 8.1 shows the variation of thermal conductivity of concrete as a function of temperature. Similar relationship exists for petroleum well cements. The variation in thermal conductivity leads to non-uniform setting of a cement slurry that in turn triggers non-uniformity in mix properties, such as moisture content and permeability. Similar effects are also expected from pressure change as well. Casing and cement react to temperature in different manners when they are exposed to pressure and temperature changes. If the cement expands more than the casing during temperature and pressure loads, they may get separated and generate a micro annulus

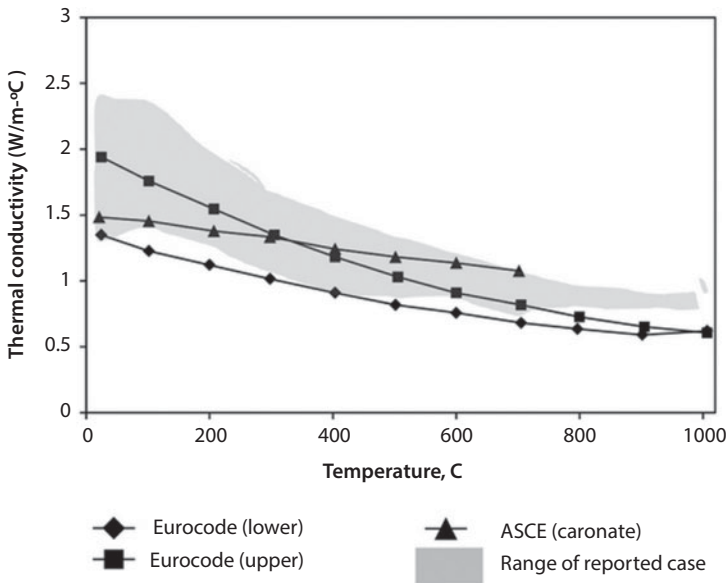
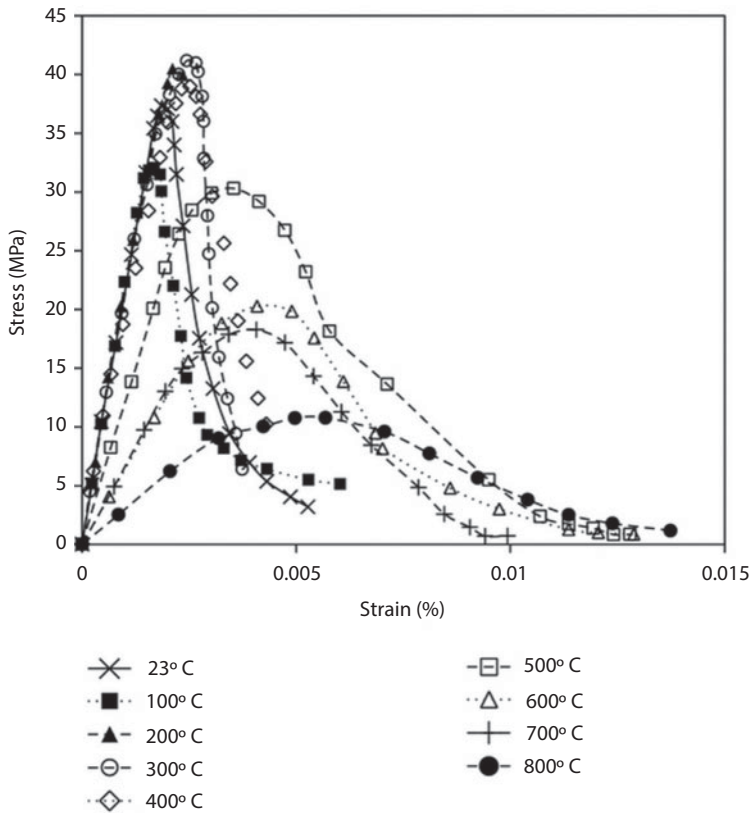

**Figure 8.1** Variation in thermal conductivity of normal strength concrete as a function of temperature (from Kodur, 2014).

around the casing. Such a micro annulus impacts the casing integrity in two ways. If the micro annulus extends over a long interval, it may become a vehicle for fluid migration causing sustained casing pressure (SCP). In addition, the existence of a micro annulus further disrupts the cement setting process, which would eventually affect casing integrity. Both temperature and pressure changes can create mechanical shocks to the cement system. They may also occur during tripping. In each instant, weakening of the casing cement bond occurs, forming a micro annulus at the interface or creating cracks within the cement body. The mechanical response of concrete is usually expressed in the form of stress-strain relations that lead to variations in compressive strength as well as ductility of concrete.

Figure 8.2 shows how the slope of stress-strain curve decreases with increasing temperature. The strength of concrete has a significant influence on stress-strain response both at room and elevated temperatures. All cases exhibit a linear response followed by a parabolic response till peak stress, and then a quick descending portion prior to failure. The point here is such dynamic change in rheology which can onset cracks and channels within the cement body and lead to a faulty cementing job.

Either a poor primary cement or any damage to the primary cement can lead to SCP, resulting in different problems with consequences on the



**Figure 8.2** Stress-stress response of concrete at various temperatures (from Kodur, 2014).

drilling process. Even if the primary cement job is well done, there are certain events that can cause cement damage. Such events are for example invasion of the annulus by the formation fluid, which may be corrosive to the casing. Such invasion is possible if the formation pressure is consistently higher than the annulus pressure. This is illustrated in Figure 8.3.

In this figure, formation pressure,  $P_1$  is greater than the hydrostatic cement slurry pressure,  $P_2$ . Due to the pressure gradient toward  $P_2$ , formation fluid will migrate upward through the cement annulus. This fluid in turn can invade other zones within the same formation that have lower pressure prevalent within them. The remedy to this problem is to ensure  $P_2$  is greater than  $P_1$ . This can be achieved through adjustment of density of the slurry so that the hydrostatic pressure of cement slurry remains greater than the formation pressure. However, the hydrostatic pressure should not be higher than the fracturing pressure. Otherwise slurry may be lost and well may lose control.

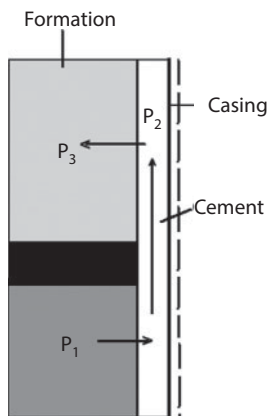

**Figure 8.3** Pressure differential within the subsurface can trigger fluid migration through the annulus.

Another problem related to cement leaks is the formation of channels that form at the top of the liner as well as cement shoe. This problem can be remedied by squeezing cement into the affected area. However, channels in between cannot be remedied due to lack of access to them. It is therefore important to ensure that the primary cementing is of good quality. Some factors contributing to cementing are mud characteristics, pore pressure and fracture pressure in zones that can get connected through channels and create a cross flow. One factor to consider is the fact that the ability of gel to transmit hydrostatic pressure decreases with time. This may allow fluids to enter the cement and form channels during the hydration process. Irrespective of the quality of cementing process, the hydration phase is vulnerable to fluid invasion either from the reservoir or from other formations containing fluid at high pressure.

In order to ensure cementing conforms to a standard, oil companies provide one with a guideline. In absence of strict adherence to the guideline renders a cement job incomplete. Table 8.1 gives an example of such guidelines from Norwegian oil company, Norsok.

#### 8.1.1.1 Preventive Methods

Any remediation is more difficult than prevention. As pointed out decades ago by Smith (1984), who wrote: “The added cost to perform a successful primary job is much less than the cost of remedial work to repair a failure (not to mention the potential delay or loss of production).” It is for this matter therefore, substantial savings are possible with a good successful

**Table 8.1** Acceptance table for casing cement according to NORSOK standard D-010 2004, Table 22 (From Norsok Standard, 2018).

Features	Acceptance criteria	See
A. Description	This element consists of cement in solid state located in the annulus between concentric casing strings, or the casing/liner and the formation.	
B. Function	The purpose of the element is to provide a continuous, permanent and impermeable hydraulic seal along hole in the casing annulus or between casing strings, to prevent flow of formation fluids, resist pressures from above or below, and support casing or liner strings structurally.	
C. Design, construction, and selection	<ol style="list-style-type: none"> <li>1. A design and illustration specification (cementing programme) shall be issued for each primary casing cementing job.</li> <li>2. The properties of the set cement shall be capable to provide lasting zonal isolation and structural support.</li> <li>3. Cement slurries used for isolating permeable and abnormally pressured hydrocarbon bearing zones should be designed to prevent gas migration.</li> <li>4. The cement placement technique applied should ensure a job that meets requirements whilst at the same time imposing minimum overbalance on weak formations. ECD and the risk of lost returns during cementing shall be assessed and mitigated.</li> <li>5. Cement height in casing annulus along hole (TOC):               <ol style="list-style-type: none"> <li>5.1. <b>General:</b> Shall be 100 m above a casing shoe, where the cement column in consecutive operations is pressure tested/ the casing shoe is drilled out.</li> <li>5.2. <b>Conductor:</b> No requirement as this is not defined as a WBE.</li> </ol> </li> </ol>	ISO 10426-1 Class "G"

*(Continued)*

Table 8.1 Cont.

Features	Acceptance criteria	See
C. Design, construction, and selection	<p>5.3. <b>Surface casing:</b> Shall be defined based on load conditions from wellhead equipment and operations. TOC should be inside the conductor shoe, or to surface/seabed if no conductor is installed.</p> <p>5.4. <b>Casing through hydrocarbon bearing formations:</b> Shall be defined based on requirements for zonal isolation. Cement should cover potential cross-flow interval between different reservoir zones.</p> <p>6. For cemented casing strings which are not drilled out, the height above a point of potential inflow/leakage point/permeable formation with hydrocarbons, shall be 200 m, or to previous casing shoe, whichever is less.</p> <p>7. Temperature exposure, cyclic or development over time, shall not lead to reduction in strength or isolation capability.</p> <p>8. Requirements to achieve the along hole pressure integrity in slant wells to be identified.</p>	ISO 10426-1 Class “G”
D. Initial verification	<p>1. The cement shall be verified through formation strength test when the casing shoe is drilled out. Alternatively, the verification may be through exposing the cement column for differential pressure from fluid column above cement in annulus. In the latter case the pressure integrity acceptance criteria and verification requirements shall be defined.</p> <p>2. The verification requirements for having obtained the minimum cement height shall be described, which can be</p> <ol style="list-style-type: none"> <li>verification by logs (cement bond, temperature, LWD sonic), or</li> <li>estimation on the basis of records from the cement operation (volumes pumped, returns during cementing, etc).</li> </ol> <p>3. The strength development of the cement slurry shall be verified through observation of representative surface samples from the mixing cured under a representative temperature, and pressure. For HPHT wells such equipment should be used on the rig site.</p>	

**Table 8.1** Cont.

Features	Acceptance criteria	See
E. Use	None	
F. Monitoring	<ol style="list-style-type: none"> <li>1. The annuli pressure above the cement well barrier shall be monitored regularly when access to this annulus exists.</li> <li>2. Surface casing by conductor annulus outlet to be visually observed regularly.</li> </ol>	WBEAC for "well-head"
G. Failure modes	<p>Non-fulfilment of the above requirements (shall) and the following:</p> <ol style="list-style-type: none"> <li>1. Pressure build-up in annulus as a result of e.g., micro-annulus, channeling in the cement column, etc.</li> </ol>	

primary cement job that takes all the preventative measures. In order to prevent cement leaks, the following measures can be taken.

1. Identify causes of inadequate cementing: Potential sources may be corrosive fluid, erosive materials, fluids with incompatible pH, and mitigating pressure and temperature conditions. The presence of such elements should be monitored and their impact on cement slurry studied. We have discussed the role of temperature and pressure; also should be considered the role of native fluid, sands, and others. Erosion and corrosion can be monitored through surface samples and by downhole inspection such as caliper. The cementing program, including composition of the cement slurry, should be custom designed based on the prevailing conditions in the wellbore.
2. Avoid unnecessary loading of the well. Such extraordinary loading is imparted when a well that is shut in started up. Such events create significant changes in temperature and pressure within a short period of time that might be taxing on the well, creating unfavorable conditions for cementing.
3. When the cement job outside the production casing is planned, it is important to consider both pore and fracture pressure to be able to design an adequate top of casing (TOC). It is important that TOC is so high that the requirements for setting of the production packer can be acquired with an acceptable margin.
4. If two fluid bearing zones are supposed to be drilled through with the same mud, precaution has to be taken with regard to the cementing, as demonstrated in a previous section. It is

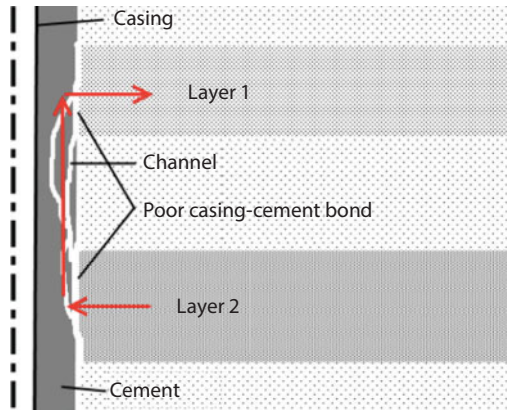

**Figure 8.4** Pore pressure in layer 2 is larger than the fracturing pressure in layer 1 (From Eikås, 2012).

important to make sure that the pore pressure in the lower zone is not too close to the fracture pressure in the upper zone. Figure 8.4 shows an example, for which pore pressure in layer 2 is greater than the fracture pressure in layer 1. Consequently, channels are formed within the cement body before it gels, resulting in crossflow between two layers, thus further affecting the gelling process.

5. Prior to any cement job, it is also important to remove mud cake as much as possible from the cement/formation interface. The presence of mud cake can give rise to weak bonding between cement and casing and lead to further formation of permeable annulus which is vulnerable to cement leaks and connecting of the channels. Also, residual mud cake may create a route for gas to flow up the annulus and lead to SCP.

### 8.1.2 Key Seating

Key seating is a phenomenon that can occur at the dogleg, where a new hole is created by the drillstring until the drillpipe is stuck at the borewall. Key-seat is encountered in deviated holes, when the drillpipe wears into the wall. It is because the drillpipe, which is of smaller diameter than the drill collars, rubs against the side of the hole and wears a slot (Figure 8.5). During the passage through a dogleg, the drillstring attempts to straighten the dogleg by exerting a lateral force. This lateral force ends up forcing the joint to dig into the formation at the dogleg bow. Thus, the extra hole



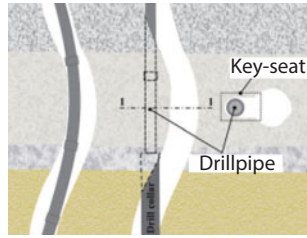

**Figure 8.5** Key-seating.

usually has the same diameter as the tool joint. As a result, the drill collars cannot pass through the secondary hole while tripping out. Key seating is diagnosed when the drillpipe can be reciprocated within the range of tool joint distances or until the collar reaches the key seat, while pipe rotation and circulation remain normal. Even though drilling ahead can continue, key-seat effects set in while pulling out.

Two conditions should be met before a key-seat is formed. The formation has to be soft and the hanging weight below the dogleg has to be large enough to create a threshold lateral force. The problem of key-seating can be identified only during the downward movement of the drillstring.

### 8.1.2.1 Prevention

Dogleg severity leads to lateral forces that lead to the formation of key-seat. This type of problem is likely to occur in soft formation while dropping angle. The problem can also develop at ledges and casing shoes, where the groove is dug into the metal instead of the formation (Matanovic *et al.*, 2014). The formation of key-seats is directly linked to the number of rotating hours. As usual, prevention is better than remediation. In order to prevent key-seating, the following steps can be taken:

1. Drill straight holes. For deviated wells, avoid sudden changes in hole inclination or direction of drilling. A preventative measure is to control upper hole deviation and dogleg severity throughout the well path. This would eliminate lateral forces that lead to key-seat creation (Matanovic *et al.*, 2014).
2. Dogleg severity should be minimized by better monitoring the drilled subsurface in real-time and making adjustments in drilling parameters.
3. Minimize pipe rotation. Each time, a pipe rotation leads to unintended reorientation downhole and can onset formation of dogleg or aggravate the conditions in favor of key-seating.

4. Design the Bottomhole assembly (BHA) in such a way that the formation of dogleg is avoided. Typically, the “PACKED” BHA is designed to drill straight holes and to reduce the severities of doglegs, key seats, and ledges. It provides the highest assurance that casing can be run into a hole. The theory which supports the packed BHA was developed by Roch. The packed hole assemblies are used when it is necessary to keep angle and direction change to a minimum. In directional wells, packed hole assemblies are used after the maximum drift angle is reached and it is desired to maintain the angle. The stiff rigid assembly fits closely in the hole and is held in place by multiple stabilizers. The stabilizers are normally placed at 0-10'-40' or 0-10'-40-70' above the bit (Figure 8.6). The rigidity and stiffness force of the BHA should remain in the same relative position. It is desirable to have higher stiffness and rigidity that would maximize efficiency.
5. Minimize the length of the rat hole below the casing. In traditional reaming-while-drilling BHA, the reamer is placed above the rotary steerable system (RSS) and logging-while-drilling (LWD) tools, creating a long rathole and requiring an extra trip to enlarge the hole to total depth. The recently developed Halliburton tool, TDReam™ enables the rathole length to be reduced to less than 3 ft without requiring an extra trip. The tool is activated at TD to enlarge the rathole left below the reamer.

#### 8.1.2.2 Remediation

The following remedies can be implemented.

1. The hole should be reamed. When the small-diameter portion of the hole is reamed with a reaming tool, the immediate problem of stuck-pipe is solved. This process is shown in Figure 8.7. However, the key-seat problem can return unless preventative measures are taken (Matanovic *et al.*, 2014)
2. Organic fluids can be spotted to reduce friction around the key-seat in order to facilitate the working of the pipe.
3. As stated earlier, after the key-seat is formed, downward movement can continue. But, in order to remedy a key-seat, the drillstring should be worked upwards gradually. However, this process becomes increasingly difficult if the

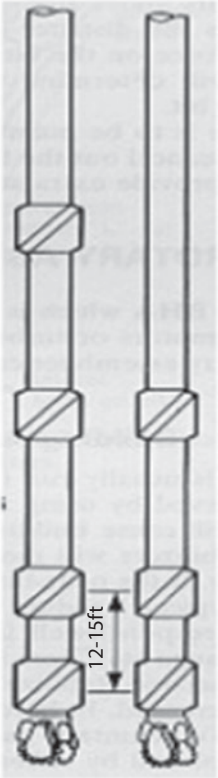

Figure 8.6 Packed hole assembly.

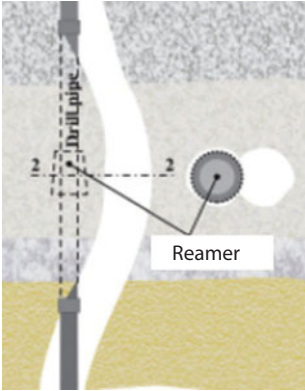

Figure 8.7 Key-seating, reaming helps.

key-seat has been in place for a long time or if the BHA is jammed within the key-seat. Attempts should be made to rotate the drill string up and out of the key seat with minimum tension (Baker Hughes INTEQ, 1995). In wells where this problem is expected, sometimes a tool called a key-seat reamer is included in the BHA. This is a reamer shell on a sub that is engaged to open up the hole enough for the drill collars to pass if it encounters an obstruction such as a key seat when being pulled out of the hole. The Halliburton tool, TDReam™ also falls under a similar category.

### 8.1.3 Cement Blocks

This problem is associated with dislodged cement blocks that accumulate within the bottomhole and jam against the drillstring. This dislodgment can be caused by large-sized collars and stabilizers that can break loose blocks of cement after the cement has been set and leak off test been completed (Baker Hughes INTEQ, 1995). Preventive measures include:

1. Minimize the length of the rat hole below the casing shoe;
2. Always ream rat holes or cement plugs before drilling ahead;  
and
3. Be careful when tripping back through the casing shoe.
4. If jamming occurs, attempt to dislodge or break up the obstructions by using alternating upward and downward working and jarring. These freeing forces should be gradually increased until the drillstring is freed, and if available, an acid solution can be pumped to dissolve the cement.

### 8.1.4 Problems Related to Mud/Cement Rheology

Poor cement jobs are mainly due to three key factors (Chen *et al.*, 2014; Nair *et al.*, 2015):

- a. Poor mud displacement by cements
- b. Improper mud cake removal during cementing operation
- c. Poor mixing and/or testing of cement slurry

Many of the cement related problems point to improper removal of mud cakes. In case the mud cake is not properly removed, it provides for a passage fluid through the annulus. Improper mud and mud cake displacement can be caused by many factors that were summarized by Mwang'ande (2016):

- a. Eccentric annulus
- b. Cement slurry flow regime (pattern)
- c. Mud rheology
- d. Running in casing without scrapers or applying other means of removing mud cakes
- e. Cementing technology applied.

Each of the above factors can lead to improper mud cake removal. Figure 8.8 shows the schematic of a cementing operation, so the roles of various factors can be visualized.

As discussed in previous sections, cement slurry contains cement powder in an aqueous solution. Most of the time, cement additives are also added. These additives are added in order to achieve a desired slurry property (Skalle, 2014a). The commonly used cement additives are as described in Table 8.2. The immediate effect of these additives is the alteration of the interface between mud and cement as well as cement and formation. Little is known about the exact nature of these interactions as most of the tests are focused on cement properties within a clean environment.

#### 8.1.4.1 Contamination with Oil-based Mud

Cement slurry cannot be injected continuously and must be pushed through with mud. However, an intermediary fluid has to be used as a buffer, called the spacer (Nelson and Guillot, 2006). Typically, the spacer is an aqueous fluid that contains surfactants, the presence of which makes it easier for the injection system to clean the transition zone before cement is injected. It is this fluid that cleans the mudcake, thus increasing the adhesion of the

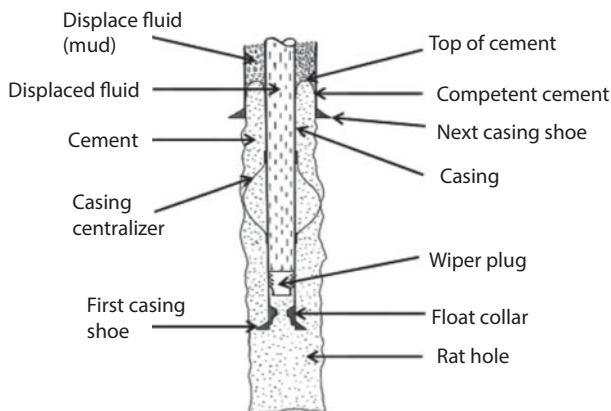

**Figure 8.8** Schematic of the cementing operation (from Mwang'ande, 2016).

**Table 8.2** Examples of cement additives with their effects on cement slurry (from Mwang'ande, 2016).

Additive category	Benefit or effect on Slurry
Accelerator	<ul style="list-style-type: none"> <li>• Shorter thickening time</li> <li>• Higher early compressive strength</li> </ul>
Retarder	<ul style="list-style-type: none"> <li>• Longer thickening time</li> </ul>
Extender	<ul style="list-style-type: none"> <li>• Lower slurry density</li> <li>• Higher slurry yield</li> </ul>
Weighting agent	<ul style="list-style-type: none"> <li>• Higher slurry density</li> </ul>
Dispersant	<ul style="list-style-type: none"> <li>• Lower slurry viscosity</li> </ul>
Fluid-loss additives	<ul style="list-style-type: none"> <li>• Reduce slurry dehydration</li> </ul>
Lost circulation control agent	<ul style="list-style-type: none"> <li>• Prevent loss of slurry to formation</li> </ul>
Specialty additives	<ul style="list-style-type: none"> <li>• Antifoam agents</li> <li>• Fibres, etc.</li> </ul>

cement with the formation (API, 2004). A spacer is selected after a series of tests involving rheological measurements, slurry sedimentation test, fluid loss, compressive strength and thickening time. The interpretation of results also considers factors such as geometry of the well, casing centralization, volume and flow rate of the fluids (API, 2004). However, current standards do not have any provision to test under simulated wellbore conditions. In addition, the scaling laws for realistic interpretation of laboratory tests are non-existent at the present time.

During injection of spacer followed by the cement slurry that is pushed by the mud system, the cement is vulnerable to contamination by oil-based mud (Li *et al.*, 2016; Soares *et al.*, 2017). It is well known that cement qualities are severely affected by the presence of oil. It's because the oil-based mud is miscible with all additives of the cement slurry, causing alteration of cement slurry properties. Oil-based mud has certain advantages, such as borehole stability, temperature stability, resistance to contamination, lubricity, and superior penetration rates for certain formations. So, contamination with oil-based mud is a common concern. In case oil-based mud is in use, it is important to determine the contamination of cement during placement, so necessary remediation measures can be taken. Figure 8.9 shows how the impact of oil-based mud (OBM) can affect cement compressive strength adversely. It is important to note in this graph that the impact of OBM is not 'felt' until a later stage and there is little impact on hydration process itself. However, in the long run, the strength would falter

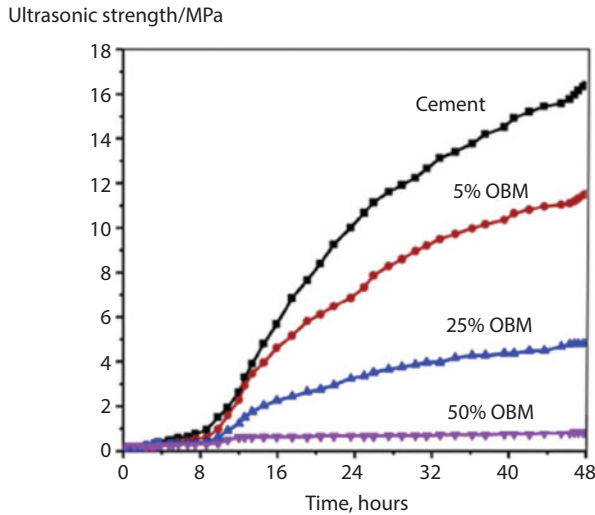

**Figure 8.9** Impact of the presence of OBM on cement strength (from Li *et al.*, 2016).

and overall casing integrity will suffer due to the presence of OBM. Soares *et al.* (2017) listed the following:

- a. The cement slurry mixture with oil-based drilling fluid causes an increase in plastic viscosity and yield point, and may compromise the maximum pumpable consistency of the cement slurry during oil well cementing.
- b. The formation of microcavities after curing time reduces the compressive strength of the set cement, and this could affect the stability of the hydraulic seal and cause well control problems.
- c. The wetting agent contacting the cement particles modifies the cement preferably wettable from the oil phase of the drilling fluid, hindering the formation of cement hydration products.

Li *et al.* (2016) observed that the presence of oil or emulsion in the cement (i) reduces the liquidity of the cement slurries and can make it immobile, (ii) reduces the compressive strength and bonding strength of the cement stone and increased the porosity and permeability of the cement stone, and (iii) lubricates between the particles of the cement skeleton, leading to the easy slippage of particles for the cement skeleton under the action of an external force.

Problems related to OBM contamination cannot be averted after the cementation is done. Therefore, it is highly recommended that compatibility tests be performed under realistic conditions prior to the cementing operation. While it is true that there is no rule or standard governing this problem, as a matter of good industry practice, such measures should be taken in order to avert any problems related to poor cementing job.

Of relevance is the recent introduction of a monitoring technique for real-time evaluation of cement. Wu *et al.* (2017) recently introduced an advanced distributed fiber-optic sensing system to evaluate the quality of cementing job and the state of zonal isolation in an oil and gas well. Based on the temperature profiles obtained during cement hydration, the actual setting time can be determined in real time. In addition, contamination of the cement slurry by mud can also be detected and the displacement efficiency can be estimated. The system is capable of identifying and locating cemented and uncemented sections. This can be used in an actual field application to determine the TOC and cement defects such as channels, cracks and voids. Although this technique has yet to be tested in the field, it does offer an opportunity to research into real-time adjustment of a cementing operation.

#### 8.1.4.2 Problem Related to Eccentric Annulus

When the casing is not well centralized in the wellbore, cement slurry flows more easily and faster through the wider annular gap. The flow rate being proportional to  $d^5$ , where  $d$  is the equivalent diameter of the cross section available for flow, the difference in velocity can be significant between the larger and narrower sides of the annulus. In the narrower gap, displacement lags behind and may be incomplete. This non-uniform annular fill-up and/or incomplete cement placement in the annulus can lead to unreliable zonal isolation, with areas of high capillary pressures that do not allow any cement propagation (Wu *et al.*, 2017). Figure 8.10 shows the differences in mud heights in the annulus for both widest and narrowest sides. Note how mud flows in the narrowest sector while cement on the widest side. An eccentric annulus has the same cross-sectional area as the concentric annulus. However, the flow through the eccentric annulus exhibits various forms. Figure 8.11 shows how velocity profiles change with varying standoff values. If a casing is perfectly centered, the standoff is 100%. A standoff of 0%, on the other hand means that the pipe touches the wellbore. Regardless of the centralizer type, the goal is to provide a positive standoff, preferably above 67%, throughout the casing string. The goal here is to maximize standoff by using as many centralizers as needed. The casing



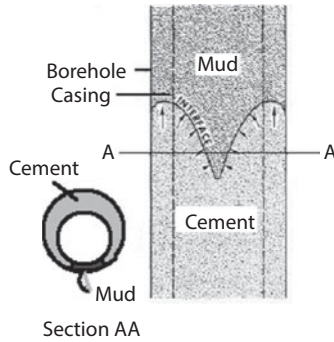

Figure 8.10 Displacement of mud affected.

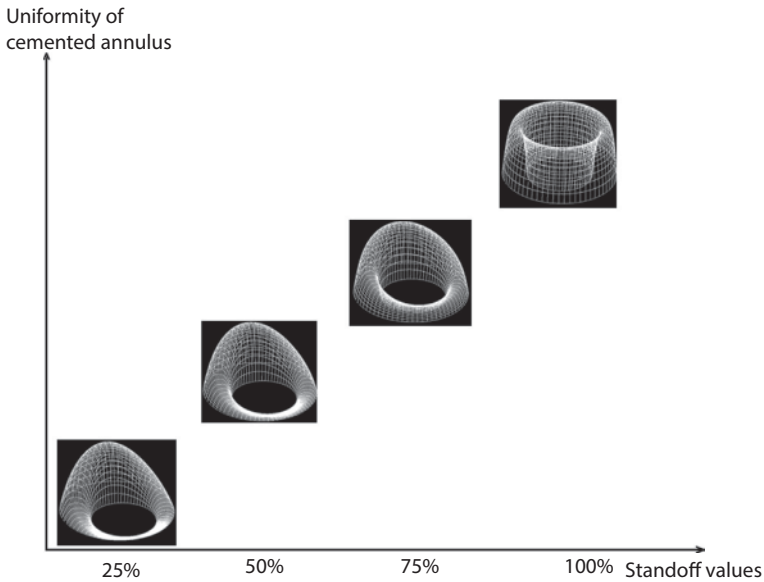
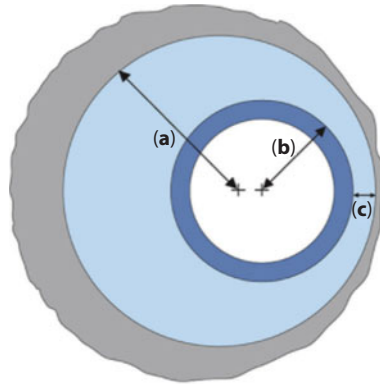

Figure 8.11 Uniformity of the cemented annulus by eccentric annulus. suffers greatly for low standoff values.

standoff itself depends on the subsequent factors: (i) well path and hole size, (ii) casing OD and weight, (iii) centralizer properties, (iv) position and densities of mud and cement slurries.

A high value of casing standoff helps reduce the mud channeling and improves the displacement efficiency. A well-centered pipe in a wellbore will lead to a more uniform axial velocity profile and shorter fluid interface length. As standoff approaches 0, the narrow side flow could even



**Figure 8.12** Standoff is 0, when casing touches the bore wall ( $C = 0$ ).

be blocked, leaving fluid not displaced. In Figure 8.12, the standoff value becomes  $C/(A-B)$ . Regardless of the centralizer type, the goal is to provide a positive standoff, preferably above 67%, throughout the casing string.

For a low standoff casing, cuttings bed becomes difficult to clean out of the annulus and can lead to significant problems for the drilling operation if the pipe becomes stuck in the cuttings bed. The problem of eccentric annulus is also common in horizontal wells where gravitational forces affect the centralization of casing string and promotes solids settling from the drilling fluids. All these abnormalities can lead to poor mud displacement during cementing.

#### 8.1.4.3 Flow Regime of Cement Displacement

For a cement slurry to be effectively placed within the casing/borehole annulus, a turbulent cement slurry phase is necessary in order to avoid problems related to narrowing of the displacement front. The turbulent flow displacement front is flat, and therefore, it displaces the chaser fluid in a piston-like motion. The laminar flow regime, on the other hand, produces narrow displacement profile resulting in poor displacement of mud (Skalle, 2014a).

Figure 8.13 shows the nature of velocity profile under a laminar flow regime. In the laminar flow regime, the profile narrows as cement propagates. By contrast, for turbulent flow the displacement profile remains as the initial profile, maintaining a piston-like displacement (Skalle, 2014a).

It is well known thinned or dispersed muds are Newtonian and are more readily displaceable than thicker muds that fall under the category

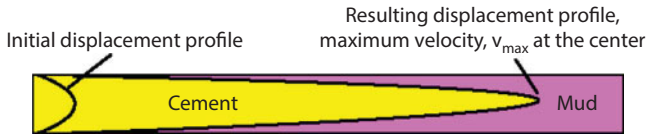

Figure 8.13 Displacement profiles affected by flow regimes.

of Bingham fluids. It is therefore advisable to condition muds before chasing the cement with them. If the Newtonian behavior is restored in mud, it would be easier for it to be injected at higher velocity with minimum frictional loss in the drillpipe, thus increasing cement slurry velocity, which would help maintain a turbulent regime for the cement slurry. Other techniques suggested are:

1. Use of centralizers to ensure casing is well centered with respect to wellbore and hence avoid non-uniform and incomplete cement placement in the annular space (Nair *et al.*, 2015).
2. Use appropriate cementing technology. Cement packer completion using Liquid Cement Premix (LCP) in off-shore Gulf of Mexico (GoM) has proved to have better results and cost saving of between 60–70% compared to when a normal workover rig is used (Eberhardt & Shine Jr, 2004).
3. Keeping cement slurry weight at least 0.24 kg/l higher than mud and circulate cement at a very low flow rate to aid displacement process. The more eccentric the annulus, the thicker must be the cement relative to the mud (McLean *et al.*, 1967). This helps to achieve a piston-like displacement in the annulus.
4. In extended reach and horizontal wells, the heavier cement is even much important than in vertical wells. When a displacing fluid with higher density than the displaced fluid is used, the lighter mud in the narrow part of the annulus will float up into the wide part and be transported away with ease (Jakobsen *et al.*, 1991).
5. Isolating the cement by plugs while it is pumped down the casing. This is necessary to ensure that the cement fills the whole annulus properly and also to avoid cement contamination with muds (Wilde Jr, 1930).
6. Establishing turbulent flow of cement slurry in the annulus to aid good mud displacement.

#### 8.1.4.4 *Improper Mud Cake Removal during Cementing*

Improper mud cake removal when running in casing string and during cementing can be caused by one or all of the following reasons which are the means of removing mud cakes properly:

- a. Running in casing string without including mechanical scrapers or scratchers
- b. Running in casing string without applying hydraulic jetting
- c. Pumping in cement slurry without treating the pre-flush fluids with acids

Other factors involved are:

- a. Eccentric annulus
- b. Cement slurry flow regime (pattern)
- c. Mud rheology
- d. Running in casing without scrapers or applying other means of removing mud cakes
- e. Cementing technology applied

Remedial procedures involve:

- a. Use of centralizers when running in casings
- b. Run casing with scratchers, hydraulic jetting or treatment with acids
- c. Thinning the mud before running in casing
- d. Isolating cement by plugs when pumping down
- e. Establishing turbulent- or plug flow of cement slurry

Casing centralizers are bow-like devices with both ends fixed on the outside wall of the casing to serve two purposes: (i) to clean wellbore (aid in removing mud cake), and (ii) to ensure that the casing string is centered relative to the wellbore (Jones and Berdine, 1940). Casing centralizers are important to ensure good cement displacement during cementing operation.

In addition to extra caution about centralizers, scratchers are also important. Mechanical scratchers are usually fixed onto the casing outside wall for the purpose of rubbing against wellbore wall when casing is rotated and moved axially. Scratchers remove any mud cake in the permeable formations leading to good cement bond with the formation.

#### 8.1.4.5 Poor Mixing and/or Testing of Cement Slurry

Field experiences for many years have shown that, without good cement formulation, good slurry mixing, and testing/simulating it, proper mud and mud cake displacement during cementing operation cannot yield good cement results even if the displacement is well done (Wu *et al.*, 2017). Good cement formulation starts at the chemistry level when cement is made at the factory. Cement mixing refers to blending/addition of other components like water, additives and/or noble gases (to make foamed cement).

Good cement slurry formulation/mixing, testing and displacement during pumping in the annulus can be well performed. However, if the annulus is not sufficiently filled, it leads to low top of cement (TOC). Insufficient annular fill-up (especially TOC) is caused by poor cement slurry volume calculation to match the annular spaces. Different methods have been developed to calculate hole volume and hence estimation of slurry volume. These techniques are:

1. Estimation of slurry volume from caliper measurements (Paternell Carballo *et al.*, 2013). The requirements for determining hole volume for wells drilled with water based mud (WBM) in deep-water environments can be met using the existing Logging While Drilling (LWD) electromagnetic propagation resistivity measurements. The hole size leading to determination of hole volume is obtained from caliper measurements (specific LWD caliper inversion processing in this method). Cement slurry volume can then be estimated based on the hole size determined by either excess percentage (150–200% of hole size) or fluid caliper values. This method is applicable in riser-less top hole sections especially in offshore Gulf of Mexico. The caliper measurements in this method are affected by large uncertainty of mud resistivity. The technique to overcome this uncertainty is by implementing a simultaneous inversion model and forward modeling database from standard 2-Mhz propagation resistivity for water-based mud (WBM) and large boreholes (top hole sections). In order to attain high accuracy in estimation of hole size and shape, the caliper tool used in this technique should be able to record the greater numbers of independent measurements. In case Wireline calipers are not available, an estimation of hole size can then be done by either specifying

a given percentage of excess of the bit size or having “Fluid Caliper” with tracer materials to detect the returns at sea floor (Peternell Carballo *et al.*, 2013).

Furthermore, this technique can advance the Measurements While Drilling (MWD) and LWD tools to enable estimation of open hole size from acoustic and nuclear measurements or resistivity measurements in conductive drilling muds (Peternell Carballo *et al.*, 2013). This advancement adds value to this method in determining hole volume compared to other methods that depend on only one means for determining the volume.

2. Cement slurry volume (Vcs) are estimated from wellbore geometrical model (Amanullah and Banik, 1987). Calculation of slurry volume in this method is based on a wellbore with circular geometrical shape. The cement slurry volume calculation is modeled by integrating  $V = f(h)$  for a constant wellbore and casing diameter. Use or mean geometric approximation is made for determining the area of the triangles. The conventional method or slurry volume calculation gives a coarse approximation due to the lack or desired level of accuracy as a result of uncertainties associated with wellbore diameter throughout the depth. To remedy this disadvantage, Amanullah and Banik (1987) use a single constant equation that divides the horizontal plane into  $n$  equal triangles and the total depth into  $m$  intervals. The slurry volume is obtained using a formula as seen in equation (8.1) and shown principally by Figure 8.14.

The main assumption in this method is that, since the open hole length is large, the inside diameter of previous casing is also assumed to be equal to the mean diameter of the open hole. The equation is modeled (developed) by integrating  $V = f(h)$  for a constant wellbore and casing diameter and dividing the horizontal plane into  $n$  equal triangles (Figure 8.15) and the total depth into  $m$  equal intervals (Amanullah and Banik, 1987).

The accuracy of this method is largely affected by the process of determination of wellbore mean diameter  $D_m$ . The bigger the number of triangles  $n$ , the higher the accuracy of the geometrical mean diameter  $D_m$ . In case, real-time data are available through any of the monitoring devices, this method can be improved greatly. Another constraint to this

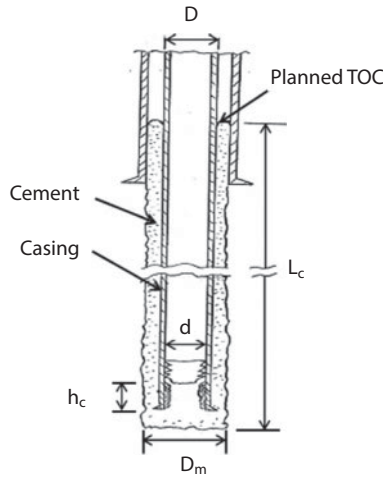

**Figure 8.14** Principal sketch describing estimation of mean diameter,  $D_m$  in equation 8.1 (Amanullah and Banik, 1987).

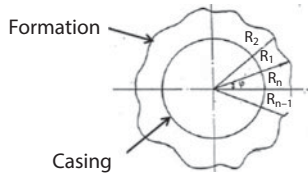

**Figure 8.15** Principal sketch describing parameters in equation (8.1)

method is that, the annular volume grows considerably as the wellbore becomes more irregular and consequently a detailed study of the wellbore configuration is essential in order to minimize the volume fluctuation from the actual (Amanullah and Banik, 1987).

$$V_{cs} = \frac{\pi}{4} k(D_m^2 - D^2)L_c + d^2 h_c \tag{8.1}$$

where

- $V_{cs}$  = cement slurry volume [m<sup>3</sup>];
- $k$  = marginal capacity factor, usually 1.2–1.3 for safety reasons;
- $D$  = outside diameter of the casing string [m];
- $d$  = inside diameter of the casing string [m];

- $D_m$  = wellbore mean diameter according to cavernogram of the section [m];
- $L_c$  = length of the cementing interval [m];
- $h$  = height [m].

3. Cement slurry volume are obtained from average hole diameter (Mian, 1992). Most drilled holes are exposed to wash-outs, ledges, caves and tight holes. Determination of cement slurry requirement for these holes is done by first calculating the average hole diameter and then using it to obtain annular volume. Determination of average hole diameter is achieved by using equation (8.2) and is described principally by the exaggerated wellbore in Figure 8.16. This method is somehow similar to method-2 presented by equation (8.1) since it is also based on determination of the average diameter. The difference is how this average/mean diameter is being estimated. The approach in this method is that the well is divided into  $j$  vertical sections of equal length  $L$  (Mian, 1992) whereas in method-2, the horizontal plane is divided into  $n$  equal sectors.

The slurry volume is then determined using equation (8.1) but the mean diameter,  $D_m$  in equation (8.1) is replaced with average diameter,  $d_{av}$  as in Equation (8.2). The higher

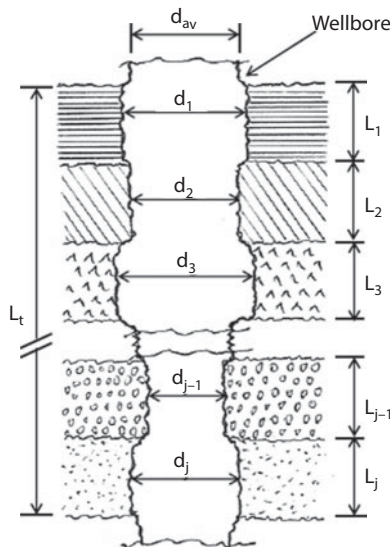

Figure 8.16 Principal sketch describing parameters in equation (8.2).



the number of vertical sections  $j$ , the higher the accuracy of the day and hence is the total volume of slurry.

$$d_{av} = \sqrt{\frac{1}{L_t}(D_1^2 L_1 + D_2^2 L_2 + \dots + D_j^2 L_j)} \quad (8.2)$$

where,

$d_{av}$  = average hole diameter;

$d_i$  = diameter of the corresponding  $n$ th section [m]

$L_i$  = length of the  $n$ th section [m]

$L_t$  = planned distance into previous casing (casing overlap length) [m]

### 8.1.5 Blowout Potentials

We have considered blowouts as a major drilling problem. In this section, however, we consider the specific aspect of blowout potentials that relates to cementing problems. In the context of the most recent catastrophic failure of Gulf of Mexico *Deepwater Horizon* events in 2010, AP (2010) reported that the major reason behind that blowout incident was cementing problems. Poor cement jobs have been attributed to other blowout events as well (e.g., August 21, 2009, blowout in Montara, Western Australia).

Ever since that event, it has come to the attention of the general public that federal regulations are not adequate as a guideline to cementing. For instance, they don't regulate what type of cement is used, leaving it up to oil and gas companies. The drillers are urged to simply follow guidelines of the American Petroleum Institute, an industry trade group. As new generations of cements are development through research arms of service companies, another problem arises from the fact that service companies are not operators and often (as was the case of *Deepwater Horizon*) they themselves contract out to another entity to complete the cementing job. Cementing can be faulty either by inherent nature of the cement and additives or by poor placement in the annulus. This is of particular safety concern for offshore wells. AP reported that 34 times petroleum well drilling disasters have been linked to cementing during the period 1978–2010. In fact, many of the reports, available from the U.S. Minerals Management Service that regulates offshore wells, identify the cause simply as "poor cement job." For instance, in a November 2005 accident, faulty cement work allowed wall-supporting steel casing to come apart. Almost 15,000 gallons of drilling fluid spilled into the Gulf. It was in the neighborhood where the *Deepwater Horizon* was positioned. Within a week, in a

nearby well at another platform, cement improperly seeped through drilling fluid. This was because of an additive that was meant to quicken setting time. It turned out that the 'new technology' failed to give the cement low enough permeability thus failing to block a gas influx into the well. When the crew finally replaced heavy drilling fluid with lighter seawater, as they also did for *Deepwater Horizon* before the blowout, the well flowed out of control and much of the crew had to be evacuated.

Similarly, cementing was identified by federal investigators as a glaring cause of an August 2007 blowout, also off Louisiana. They discovered that "the cement quality is very poor, showing what looks like large areas of no cement." Reports by MMS, a branch of the Interior Department, also provide evidence of the role bad cement work has played in accidents. One study named cementing as a factor in 18 of 39 well blowouts at Gulf rigs from 1992 to 2006. Another attributed five of nine out-of-control wells in the year 2000 to cementing problems.

There are three major U.S. cementing companies: Halliburton, Schlumberger and BJ Services. Cementing is typically performed by such rig contractors as part of a broad range of drilling services that they supply. Halliburton, which had the *Deepwater Horizon* job, mixes in nitrogen to make its slurry more elastic. The nitrogen also helps create a lightweight cement that is supposed to bond better with the casing. The problem is, there is hardly any scope to test the cement under field conditions. Of course, companies perform tests in a laboratory with similar pressure and temperature conditions, but the scaling laws that would help one to correlate laboratory results to field conditions are primitive and have not been developed for such complex materials with unusual transient profiles. The actual field conditions are difficult to assess, let alone model in the laboratory setting. When cement mix is pumped through the well, it first sinks to the bottom then oozes upward to fill the narrow spaces between the casing and the borehole. During this time, cement itself undergoes exothermic reaction and then adjusts to continuously changing temperature and pressure conditions within the wellbore.

It is also important to note that every accident comes with an early sign. For instance, SCP is an indicator that can signal a poor cement job. In fact, in a 2007 blowout of the Gulf of Mexico well, investigators cited tests showing high casing pressures that could have indicated suspect cement work. The platform owner reported a problem to federal regulators, but nothing was done before the blowout.

More than 8,000 of the 22,000 offshore wells on federal leases, most of them in the Gulf, show sustained pressure, according to government reports. Of course, this data would be used by some to show that because SCP is frequent, whereas the number of accidents aren't, that must mean

SCP cannot be an indicator for an impending accident. The problem with this argument is, monitoring data on SCP are not complete and are rarely analyzed unless there is an accident that triggers an investigation. Had there been a protocol to maintain low or negligible SCP, one would avert the accidents altogether. Also, high SCP is never acceptable and such an incident occurs much before the actual blowout. For instance, a month after the *Deepwater Horizon* explosion, regulators wrote in the Federal Register that the oil and gas industry in the Gulf has “suffered serious accidents as a result of high sustained casing pressure, and the lack of proper control and monitoring of these pressures” (AP, 2010).

Often oil companies wait for the regulations to dictate their modus operandi. This view is short-sighted. Regulators have long been accused of being too ‘cozy’ with oil companies to be objective. Even after the *Deepwater Horizon* explosion, new rules that took effect within just a few months of the incident still took a conservative watch-and-wait approach and demanded only routines already carried out around the industry: a management program with monitoring and diagnostic testing. There are no new record-keeping or reporting requirements in the new rules. Not surprisingly the rules were backed by the industry that continues to view regulations as ‘a drain’ to the profit margin. The situation was summed up by U.S. Rep. Diana DeGette (D-Colo.), a member of the Energy Committee, in her statement: “Unfortunately, this is yet another crisis in a long line of accidents caused by cementing problems in drilling.”

#### 8.1.5.1 Overall Guidelines

The following guidelines can be provided:

1. There is no substitute to good primary cementing. Avoid using new products, especially the ones that are designed to rush time of setting. Usually, they are the most frequent source of cement failures.
2. For complex formations, scaled model studies must be made before cementing in order to determine the composition as well as pumping rate and setting time.
3. Identify early warning signs. The SCP values should be monitored closely and preventative measures taken before proceeding to next phase of drilling.
4. Don't wait for regulations to dictate your cementing practices. Drilling regulations are inadequate and oil operators must develop their own standard that conforms to zero tolerance policy.

## 8.2 Good Cementing Practices

The requirements for good displacements and hence successful cementing jobs have been described in previous sections. Jakobsen *et al.* (1991) conducted an experimental work using a 60° inclined large-scale deviated apparatus simulating a deviated wellbore which proved that when a displacing fluid has higher density than the displaced fluid by 5%, the latter fluid floated up in the wider annular space due to buoyancy and was therefore transported with ease leading to efficient displacement. Similarly their experimental work went on further to determine the effect of viscous forces, as determined by viscosity differences between displaced and displacing fluid. It was concluded that as the viscosity of mud (i.e., displaced fluid) becomes lower than that of cement (i.e., displacing fluid), a better displacement was achieved. This validated the long-standing notion that viscosity induced instability is minimized with favourable viscosity ratio. In this particular application, Smith and Ravi (1991) used this notion to argue that mud thinning should take place to ensure piston like displacement of the mud. Failure to adhere to the cementing standards will obviously lead to failure of cement jobs. However, within that framework, one should maximize the viscosity ratio of the displaced over displacing fluids. Loss of control of one of the mentioned factors can lead to adverse consequences, such as (O'Neill and Tellez, 1990):

1. Poor cement bonding with either casing or formation or both
2. Incomplete annular fill-up by cements during cementing leading to poor displacement efficiency
3. Lower compressive strength of the set cement
4. Inefficiency of cementing additives
5. Erroneous cement slurry thickening time
6. Possibility of inability to control formation pressure especially if slurry density control is lost.

Studies of the individual cementing variables should be combined to lead to a total cement-job design approach that results in effective zonal isolation in critical wells. For the proper design of cement columns in wells, a thorough understanding of the mechanism causing loss of hydrostatic head of a cement column is needed (Hartog *et al.*, 1983). Often, laboratory tests are required in order to simulate realistic field conditions but these data are not required by the industry or regulatory agency standards. A good business practice would be to collect such data on

cement rheology, fluid-loss control, slurry stability, and setting behavior. Attention should also be given to mud conditioning, batch mixing, scavenger slurries, and spacers. Efficient mud displacement is achieved with high cement-displacement rates, reciprocation, and suitable cement rheologies and contact times. Each of these variables should be optimized. Theoretical models exist but they are not adequate for guiding cementing operations in a vulnerable environment. A good understanding of the parameters that control the displacement of mud by cement slurry must be developed with custom designed study of the specific field of concern.

Crook *et al.* (2001) published a recipe for good cementing jobs. This document from nearly two decades ago remains valid today and subsequent disasters related to the failure of cement jobs add to the need of following a good business practice. They identified eight governing factors that determine the integrity of a cement job. They are: (i) condition the drilling fluid, (ii) use spacers and flushes, (iii) move the pipe, (iv) centralize the casing, (v) maximize the displacement rate, (vi) design slurry for proper temperature, (vii) select and test cement compositions, and (viii) select a proper cementing system.

### 8.2.1 Drilling Fluid

The drilling fluid condition is the most important variable in achieving good displacement during a cement job. It is common to have gelled pockets within the drilling fluid, especially during downtime when the casing is being prepared for installation. The formation of gelled bodies denotes the thixotropic properties of the mud and is a measurement of the attractive forces of the mud while at rest or under static conditions. As this and yield point (YP) are both measures of flocculation, they will tend to increase and decrease together. The YP is the attractive force among colloidal particles in drilling mud and is the yield stress extrapolated to a shear rate of zero on the stress-strain graph. It represents the characteristic feature of the Bingham plastic model. Plastic viscosity (PV) is the other parameter of the Bingham-plastic model. YP is used to evaluate the ability of a mud to lift cuttings out of the annulus. A high YP implies a non-Newtonian fluid, one that carries cuttings better than a fluid of similar density but lower YP. YP is lowered by adding deflocculant to a clay-based mud and increased by adding freshly dispersed clay or a flocculant, such as lime. Laboratory testings must be done to determine the probability of gel formation within the timeframe of a casing installation operation. Special considerations should be made if oil-based muds are being used. It's for gelling standpoint and contamination prospects.

High temperature – the high temperature environment tends to increase the YP in the water based mud. Contaminants such as carbon dioxide, salt, and anhydrite in the drilling fluids. Equivalent Circulating Density (ECD) – The ECD typically increases when the YP increases and must be considered for the design purposes.

### 8.2.2 Hole Cleaning

While drilling a large diameter hole, the YP in the drilling mud must be high in order to help hole cleaning efficiency. In order to get the most optimized value of PV for each a particular drilling campaign. It is difficult to determine an optimal level of PV for a particular operation and the best procedure is to build from experience, either from neighboring wells or from the well itself. In this, real-time monitoring can be very helpful.

### 8.2.3 Gel Strength

The gel strength is the shear stress of drilling mud that is measured at low shear rate after the drilling mud is static for a certain period of time. The gel strength is one of the important drilling fluid properties because it demonstrates the ability of the drilling mud to suspend drill solid and weighting material when circulation is ceased.

For a drilling fluid, the fragile gel is more desirable. In this case, the gel is initially quite high but builds up with time only slightly. This type of gel is usually easily broken and would require a lower pump pressure to break circulation. As part of good practice, one must ensure the pockets of gelled fluid are broken up.

Regaining and maintaining good fluid mobility after running the casing is the key. Drilling fluids with low gel strengths and low fluid loss are the easiest to displace. That type of high velocity with low pressure drop would enable driller to maintain turbulent flow for the cement. The advantage of having a turbulent regime has been discussed in previous sections. To condition the drilling fluid in preparation for a cement job, operators are encouraged to follow the following measures:

1. Determine the hole volume that can be circulated.
2. Evaluate the percentage of wellbore that is actually being circulated.
3. Remember that returned fluids are not reliable indicators of the fluid in the annular space.

4. Use a fluid caliper or material balance to determine downhole fluid mobility and check for annular fluid that is not moving.
5. Circulate the drilling fluid to help break the gel structure of the fluid. If predetermined data indicate that gel pocket formation is probable, change the composition of the drilling fluid to avoid gelling within the time frame of a cement job.
6. Condition the drilling fluid until equilibrium is achieved. After the casing is on bottom and before the displacement begins, circulating the mud decreases its viscosity and increases its mobility.
7. Do not allow the drilling fluid to be stagnant for an extended period of time, especially at elevated temperatures. When the drilling fluid is well conditioned (the mud properties coming out of the well are the same as the mud pumped in), continue circulating until the displacement program begins.
8. Modify the flow properties of the drilling fluid to optimize mobility and drill cuttings removal. Laboratory tests and even some crude testing with real cuttings in the field can be helpful.
9. Examine the mud gel strength profile, during the job planning stage and just before the cement job. Measure gel strengths at 10 sec, 10 min, 30 min, and 4 hr. An optimum drilling fluid will have flat, nonprogressive gel strengths. For example, it will have 6-rpm gel strength values of 1, 3, and 7-lbf/100 sq ft on a Fann 35 viscometer at 10 sec, 10 min, and 30 min, respectively.
10. Measure the gel strength development during the job planning stage, at downhole temperature and pressure.
11. Drilling fluid left in the well at elevated temperatures and pressures can gel to a consistency that prohibits removal. These increased gel strengths are not detectable at surface conditions.
12. Deviated wellbores usually require higher-viscosity drilling fluids to prevent solids from settling on the low side of the hole. Larger drill cuttings in the system also require that higher-viscosity fluids be used. Optimum use of higher-viscosity fluids should be driven by wellbore conditions and inclination.

### 8.2.4 Spacers and Flushes

Spacers and flushes are effective mud displacement aids and are an integral part of an effective cementing technique. As discussed earlier, the spacer is needed to clean the wellbore ahead of the cement. It keeps the cement isolated from the mud in order to prevent contamination of the cement, thereby losing vital properties. Figure 8.17 shows relative positioning of various components of the casing and fluid systems. In terms of operation, spacers enhance gelled-mud removal and allow better cement bond with the borehole (Figure 8.18). Various types of spacers can be added in order to control the wellbore chemistry surrounding the cement. For instance, weighted spacers help with well control, whereas reactive spacers provide increased mud-removal benefits. The fluid compatibility should be the most important consideration for the selection of a spacer and tests should

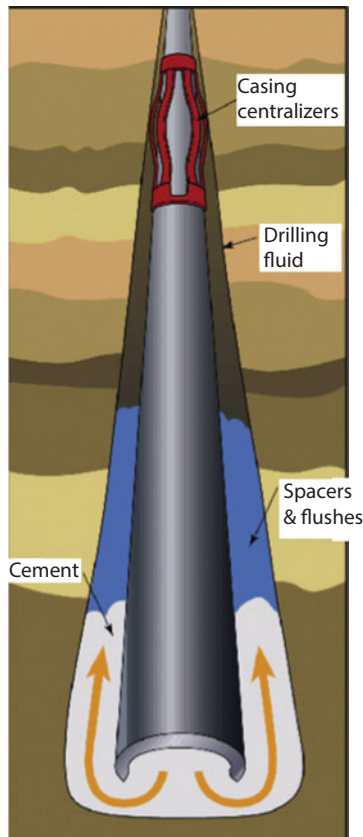

Figure 8.17 Spacers help keep fluids isolated (From Crook *et al.*, 2001).



be performed under realistic scenarios. Of course, API guidelines regarding well testing must be met, but operators are better off going beyond meeting the API standards. This is particularly true if a new type of cement additive is being used or if the drilling is in a region vulnerable to unpredictable behavior of the rock/fluid system.

Flushes are used for thinning and dispersing drilling-fluid particles. These fluids are mainly aimed at cleaning the wellbore and ridding it of mud residues. It is important to pump these fluids a velocity high enough to maintain turbulent flow in the annulus. Because the viscosity of flushes is low, it is relatively easy to maintain turbulent flow with reasonable pump pressures. Depending on the nature of mud and its mobility, sometime it is desirable to add chemicals that clean the hole by oxidizing heavier components of the residues from the mud. In order to maximize displacement efficiency, the following guideline is offered, based on expert opinions and research findings, as discussed in earlier sections.

1. Pump the spacer fluid at an optimized rate or as fast as possible without exceeding the fracture pressure breaking down the formation.
2. Conduct compatibility tests on spacer under realistic conditions prior to finalizing the selection.
3. Provide spacer contact time and volume to remove the greatest possible amount of mud.
4. Calculate the actual job time, using the slurry volume and average displacement rate. Limit the amount of trouble time to 1-1.5 hr. To calculate the approximate thickening time for slurry design, add 1-1.5 hr to the job time.

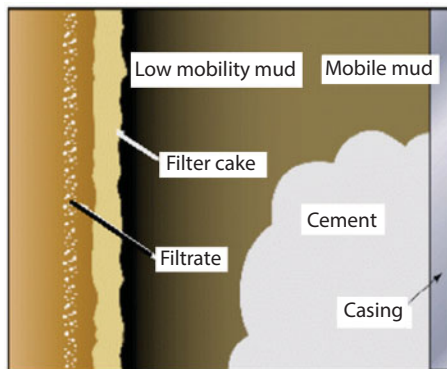

**Figure 8.18** Positioning of filtrate, filter cake vis a vis mud mobility (From Crook *et al.*, 2001).

5. Make sure the viscosity, yield point, and density of both the spacer and the cement slurry, are at least the same as the drilling fluid.
6. Take extra caution while using OBM, in which case the spacer has to be designed to water-wet the surface of the pipe and formation thoroughly.
7. One should test the spacer system using a new API apparent wettability testing technique. The technique allows the spacer-surfactant package to be customized, ensuring optimal water-wetting performance. Heathman *et al.* (1999) developed an accurate and fast screening tool that detects wettability. This test procedure can be used.
8. The ideal cement slurry has no measurable free water, provides adequate fluid-loss control, has adequate retarder to ensure proper placement, and maintains stable density to ensure hydrostatic control.
9. The ideal displacement of cement slurry is in the turbulent flow regime. All pumping calculations should be made to maintain turbulent flow regime.
10. One should not add dispersants and retarders in excess of the amounts indicated by wellbore conditions. Just enough fluid-loss control material should be added to allow cement placement before it gels.

### 8.2.5 Slurry Design

Several criteria affect slurry design. Any of these factors can become a trouble spot in case design criteria if they are not considered adequately. These criteria are listed below:

1. **Well depth:** Deeper wells have inherently more vulnerability.
2. **Bottomhole static temperature (BHST):** This would affect cement performance greatly and must be considered during compatibility test. Operators can optimize slurry design if they know the actual temperature the cement will encounter. Bottomhole cementing temperatures affect slurry thickening time, rheology, set time, and compressive-strength development.
3. **Drilling fluid hydrostatic pressure:** It is important considering each fluid of concern is non-Newtonian and fractures may be induced if fracture pressure is exceeded.

4. **Drilling fluid type:** For this, compatibility tests are important for spacers and muds.
5. **Slurry density:** Both low and high density have advantages and disadvantages and must be optimized.
6. **Lost circulation:** Geology must be properly understood and possibility of lost circulation taken in account. Cement dehydration from the loss of filtrate to permeable formations can cause bridging and increased friction pressure, viscosity, and density. Pump pressures can increase. Additives can be used to provide fluid-loss control when necessary to compensate for dehydration.
7. **Gas migration potential:** Gas migration can induce channeling during the setting of the cement, making the cementing inherently vulnerable to SCP.
8. **Pumping time:** Pumping time should be calculated in order to maintain turbulent flow regime for both the spacer and the cement.
9. **Quality of mix water:** Minerals present in water can affect the cement quality and must be considered in design. Organic materials and dissolved salts in mix water can affect slurry setting time. Organic materials generally retard the cement. Inorganic materials generally accelerate cement thickening. Before the job, one should check the cement reaction and actual location mix water to ensure the formulation will perform as expected. As discussed in previous sections, contaminants in the mix water can produce large variances in thickening time and compressive strength.
10. **Fluid-loss control:** The process of controlling fluid loss or the extent of fluid loss during the transition period can be of great significance.
11. **Flow regime:** The flow regime must be maintained as turbulent. This is easily achieved for the spacer and flushes that have viscosities close water viscosity. However, for cement, turbulent flow regime has to be established deliberately, often with special focus on high pumping rate. High-energy flow in the annulus is most effective to ensure good mud displacement. When turbulent flow is not a viable option for the formation or wellbore configuration, use the highest pump rate that is feasible. The best cementing results are obtained when the spacer and cement are pumped at maximum energy, the spacer is appropriately

designed to remove the mud, and good competent cement is used.

12. **Settling and free water:** This can lead to segregation and formation of gel pockets, both being harmful to the quality of cement.
13. **Quality of cement:** Raw materials and plant processing methods vary widely and can cause cement quality to vary.
14. **Dry or liquid additives:** Additives often play conflicting roles at different concentration values. As such, careful optimization under realistic conditions must be made prior to execution.
15. **Strength development:** This transitory factor is extremely sensitive to water content, contamination, temperature, and pressure and must be carefully assessed before designing the slurry.
16. **Quality of the cement testing laboratory and equipment:** Laboratory tests should be aimed at exceeding the expectations set by the standard.

### 8.2.6 Casing Rotation and Reciprocation

Rotating and reciprocating casing before and during cementing breaks up stationary, gelled pockets of drilling fluid and helps with homogenizing the slurry. Figure 8.19 shows the configuration of the casing/wellbore system. As shown in this figure, rotating the casing can help homogenize the fluid loss. At the same time, rotating can loosen cuttings trapped in the gelled mud. Pipe movement allows high displacement efficiency at lower pump rates by maintaining a steady flow of drilling fluids.

Movement compensates partially for poorly centralized casing by changing the flow path and allowing the slurry to circulate completely around the pipe. Mechanical scratchers attached to the casing further enhance the benefits of pipe movement. The industry has not specified minimum requirements for pipe movement during cementing and as such it is left to the experience of the driller in similar regions.

In some instances, reciprocating pipe is not recommended. It can induce surge and swab pressures that promote pipe sticking and surface casing-head pressure. This is particularly true when equivalent circulating density (ECD) and fracture pressures are close to each other, leaving the drilling window quite narrow. It can also occur when shallow gas or water influx is critical. Some liner hangers and mechanical devices prevent casing movement, which must be considered during cement displacement

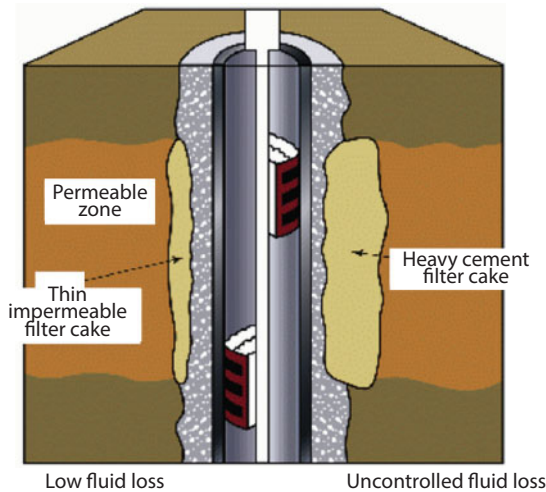

**Figure 8.19** Configuration of the casing/wellbore homogenizing the fluid loss system.

program design. The reader is directed to previous chapters to develop further insight into the process of pipe sticking.

### 8.2.7 Centralizing Casing

Centralizing casing with mechanical centralizers across the intervals to be isolated is integral to a good cement job. Without centralization, annular flow becomes inconsistent and various sides can actually maintain different flow regimes, leading to different strength and consistency. In poorly centralized casing, cement bypasses drilling fluid by following the path of least resistance. Cement travels down the wide side of the annulus, leaving drilling fluid in the narrow side (Figure 8.19). Figure 8.20 shows that cement setting is inconsistent and inhomogeneous in a case in which the casing isn't centralized.

As discussed before, a high number of pipe standoff helps ensure uniform flow patterns around the casing. Equalizing the friction loss or force that flowing cement exerts around the annular clearance increases drilling-fluid removal. The standoff values are even more critical in deviated wellbores to prevent solids from accumulating in a bed on the low side of the annulus. The best mud displacement at optimum rate is achieved when annular clearances are 1–1.5 in. There are a number of software packages available commercially that calculate the standoff values. However, the best option is to use a monitoring tool to observe anomalies in real time. Centralizing smaller annuli is difficult. Pipe movement and displacement

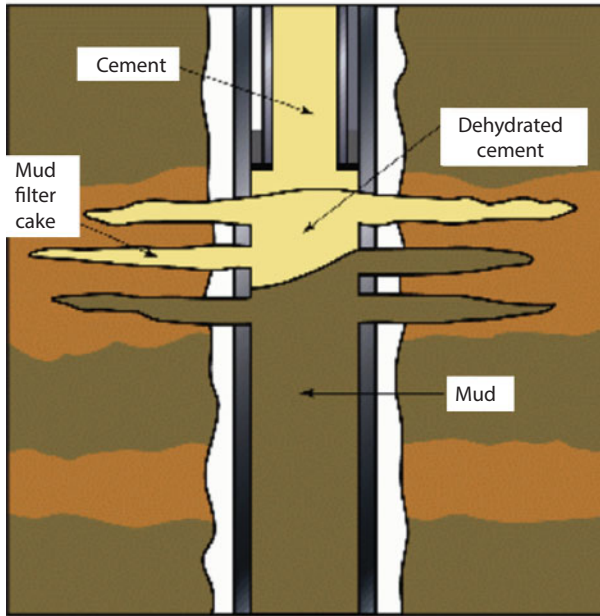

**Figure 8.20** Cement setting configuration in a non-centralized casing system.

rates are severely restricted. Larger annuli require a practically impossible redesign of the well due to telescopic nature of the well.

### 8.2.8 Displacement Efficiency

Displacement efficiency is maximized by maintaining a slug flow. However, this is rarely done in practice due to mitigating circumstances. One can optimize cost and displacement efficiency by following these guidelines:

1. Design the job on the basis of actual wellbore circulating temperatures, obtained from a downhole temperature sub recorder.
2. Estimate the bottomhole circulating temperature (BHCT) using the API Recommended Practice for Testing Well Cementing, if actual measurement is not possible.
3. Use the actual downhole temperatures measured. Do not exceed the amount of dispersants and retarders recommended for the wellbore temperature. When determining the amount of retarder required consider the rate at which the slurry will be heated.

4. Include surface mixing time when estimating job time, especially if the job is batch-mixed.

### 8.2.9 Cement Quality

Before the job, one should check the cement reaction and actual location mix water to ensure the formulation will perform as expected. Contaminants in the mix water can produce large variances in thickening time and compressive strength. Organic materials and dissolved salts in mix water can affect slurry setting time. Organic materials generally retard the cement. Inorganic materials generally accelerate cement thickening.

Raw materials and plant processing methods vary widely and can cause cement quality to vary. Cement dehydration from the loss of filtrate to permeable formations can cause bridging and increased friction pressure, viscosity, and density. Pump pressures can increase. Additives can be used to provide fluid-loss control when necessary to compensate for dehydration.

The traditional approach to cement selection has been on the basis that higher compressive strengths result in higher cement sheath quality. Today, research has proven that the ability of cement to provide good zonal isolation is better defined by other mechanical properties. Good isolation does not necessarily require high compressive strength. For instance, actual permeability and the absence of microfissures are better indicators of zone isolation. The real competence test is whether the cement system in place can provide zone isolation for the life of the well.

Field studies and laboratory research have shown that a cement sheath can lose its capability to provide isolation because of inelasticity. Annular fluid movement between zones and abnormally high annulus pressures indicate failure. Cement failure can be observed in any area of excess flowing temperatures at the surface of wellbores in which excessive internal casing test pressures are used. Applications in which cement sheath failure is a concern require the use of systems that can withstand wellbore stresses. Some cement additives impart ductile properties to cement and improve stress tolerances.

One of the most versatile systems to apply is foam cement, which produces a more ductile and resilient cement and withstands the stress associated with casing expansion and contraction. Researchers discovered that cement with approximately 25% foam quality can have the ductility and resiliency to expand and contract with the casing. However, low density foam has its own set of shortcomings that must be recognized before implementing the cement.

### 8.2.10 Special Considerations

As mentioned a few times in this chapter, API and ISO standards are not adequate for ensuring a cement job that would be free of future troubles. For instance, cementing in deep water demands consideration of a more challenging set of cementing criteria. The design considerations for these challenging conditions require considerable effort. Similarly cold temperatures, low fracture gradients, and challenging well conditions require development of custom temperature and pressure schedules for each well.

Temperature simulators should be run for each deep-water application. The API and ISO practices do not address the unique temperature and pressure conditions found in deep water environments or when there is abnormal pressure condition present in the formation. Under such scenarios, often it is impossible to employ all of the cementing practices noted in this section.

## 8.3 Case Studies

Even though any industry is focused on successes, more lessons are learned from failures than success stories. In the previous section, we have discussed best practices for a cementing job. In this section, we present field examples that demonstrate possible consequences of missteps in proper management of a cement job.

Once a failure has occurred, it is important to know the exact root cause and take countermeasures to cure the problem and if possible also to take preventive measures in order to avoid problem reoccurrences. Each failure, therefore, is associated with remedies and possible preventative measures in future operations.

### 8.3.1 Causes of Cement Job Failures

As discussed in previous sections, proper mud displacement during cementing is crucial to well completion. Various cementing challenges that lead to poor cement jobs related to displacements, wellbore geometry, and formations are presented in Figure 8.21. Figure 8.22 gives a cross sectional view of the sources of problems. This set of data are presented in Table 8.3. Figure 8.21 and Figure 8.22 show how challenging a cement job is especially if theoretical volume is incorrectly estimated (leading to poor displacement). Figure 8.21 shows the differences in actual TOC for wide and narrow annuli. It is high in the wide annulus and low in the narrow annulus.



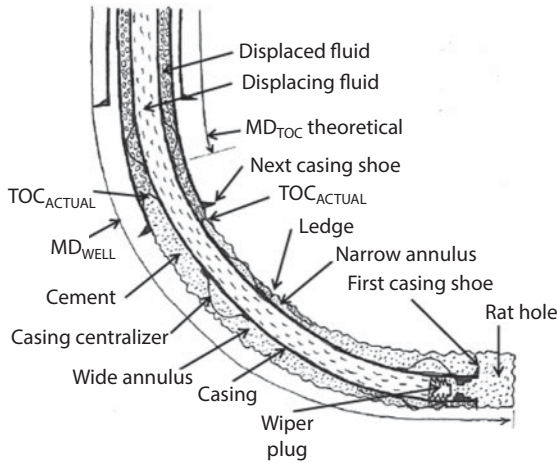

**Figure 8.21** Challenges and possible sources of problems (From Mwang’ande, 2016).

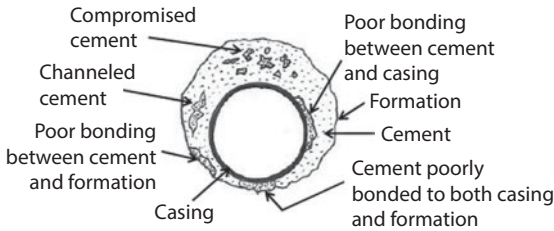

**Figure 8.22** Cross section view of sources of casing problems.

In addition, the actual TOC is below the planned TOC for both wide and narrow annuli which may lead to requirement of a squeeze cementing.

The number of casing centralizers is limited by complexity and geometry of the wellbore. As a consequence, decentralization of casing causes uneven pressure differential in the annulus which in turn leads to uneven flow of cement slurry. The result is a much difference in TOC on the narrow and wide sides of the annulus (Mwang’ande, 2016). That is, the TOC is high on the wide side and low on the narrow side as seen in Figure 8.21. The actual TOC is commonly obtained from CBL logs or similar tools.

Ledges are also another cause of poor displacement during cementing. They lead to poor cement bond especially with the formation because they block a continuous flow of cement in the annulus. If the ledge is long enough to touch the casing string, the effect is even worse since cement will then not bond with both the casing and formation as seen on the narrow side of casing annulus in Figure 8.21.

Table 8.3 List of symptoms of various cement-related problems.

Available observations “symptoms (s)/(ss)”	Description/options	Basic operator or source	Logic output
Build/Drop Section Inside Csg (ss)	When (MD, Csg. Shoe) – MD, Build/drop upper > 0		
Build/Drop Section Inside Openhole (ss)	When (MD, Csg. Shoe) – MD, Build/drop lower < 0; When inside openhole leads to csg decentralization		
Cement V/Theoretical V Low (ss)	When $V_c/V_{c.th} < 1.5 - 1.25 - 1.0$		
Csg Ann Slot Narrow	When (Bit Size – OD Csg) < 4 – 3 – 2 in Previous bit!!		
Fm Above Charged (ss)	Increasing reservoir pressure due to natural fracture in the formation or drilling fluid entering the reservoir through later induced fractures		
Fm Fault Expected (ss)	Fault intersect may add to the complexity of cementing the well		
Fm Special Expected	Here it will be defined in particular case		
Losses Expected (ss)	Known before drilling		
Well Depth High	Well TVD > 2-3-4 km		
Well Depth Shallow (ss)	When well TVD < 2-1.5-1 km		
Well Inclination High (ss)	When well inclination > 60 degrees, see WellPlan/EoW		

Well Inclination Low (ss)	When well inclination < 30 degrees,	
Well Inclination Medium (ss)	When Well inclination between 30 and 60 degrees	
Well Length High (ss)	Measured well length > 3-4-5 kmMD	
Well Openhole Long (ss)	If (MD well – MD Prev. Csg. Shoe) > 0.4 – 0.75 – 1 kmMD	
Csg Ann P High (s)	Can lead to induced LC	
Displacement Pressure High (s)	When; Frac. D – ECD < 1.0 – 0.5 – 0 kg/l	
Displacement Rate High (s)	When lead to pressure build up in the annulus	
Losses Seepage (s)	Loss < 5 – 3.5 – 2 % of pump rate	
Losses Serious (s)	Loss > 5 – 10 – 15 % of pump rate	
Packoff (s)	Restriction to cement flow caused by accumulated cuttings	
Pressure Bleeding High (s)	Pressure drop rate > 5 – 1 – 15 psi/min	

Figure 8.22 shows a poor cement job, which is caused by poor displacement during cementing. The cement has not bonded properly to both casing and formation on the narrow side and it is also compromised on the wide annulus. Channels in cements and poor bonds hold muds or spacer fluid in them. Basing on definition of displacement efficiency by equations (8.3) and (8.4). Figure 8.22 represents poor displacement efficiency of the cement job. Displacement efficiency is given by:

$$\varepsilon = \frac{\text{Pumped cement volume}}{\text{Total annular volume}} \quad (8.3)$$

$$\varepsilon = \frac{\text{Cemented area}}{\text{Annular area}} \quad (8.4)$$

To attain a successful cement job, displacement efficiency should be higher than 100%, that is, the pumped cement volume should be higher than the total annular volume to be cemented; otherwise, it will result into poor displacement job as seen in Figure 8.23 or lower top of cement (TOC) than planned.

### 8.3.2 Casinghead Pressure Problems

Sustained casinghead pressure is most likely the most ubiquitous symptom of a poor cement job. In pressure of such problems, continued operation is jeopardized and remedial action is often expensive and sometimes impossible. As Crook *et al.* (1991) pointed out for wells in federal waters of the Gulf of Mexico, the U.S. Minerals Management Service (MMS) rules and regulations, 30 CFR 250.517, concern sustained casinghead pressure. The rules say that casinghead pressures must be reported to the MMS district supervisor by the close of business on the next working day after one discovers the pressure. The rules allow a well with sustained casinghead

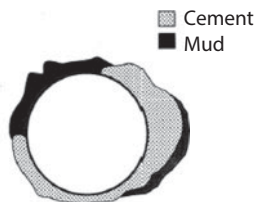

**Figure 8.23** Cross-section of a cemented annulus defining displacement efficiency of equation (8.4).

pressure that is less than 20% of the minimum internal yield pressure of the affected casing and that bleeds to zero through a 1/2-in. needle valve within 24 hr to continue producing. Diagnostic testing of all casing annuli in the well is required once sustained casinghead pressure is reported.

MMS requires a departure request to be submitted for wells with sustained casinghead pressure greater than 20% of the minimum internal yield pressure of the affected casing or for pressure that does not bleed to zero through a 1/2-in. needle valve.

Once an operator submits a departure request, additional diagnostic testing and reporting is required. One should refer to the MMS for the specific requirements. If MMS denies the departure request, the well's operator has 30 days to respond with a plan to eliminate the sustained casinghead pressure. Under certain conditions, denials may require shorter time periods for correction of the problem.

Crook *et al.* (2001) reported that about 36,000 wells have been drilled to date in the GoM Outer Continental Shelf waters by 2001. Of these, the MMS reported that 11,500 casing annuli in 8,000 wells have had reportable casinghead pressure. After the 2010 disaster, the production declined but ever since has picked up (Figure 8.24). The problem of casing pressure also rose.

In 2000, the MMS received 672 departure requests for casing annuli pressure problems, of which it processed 632. Of these requests, MMS allowed 217 wells to continue operation with specific monitoring requirements for a fixed time period, after which a new departure request is required. Another 238 wells had casing pressures less than 20% of the minimum internal yield pressure of the affected casing. Also, the pressure could be bled to zero and MMS allowed those to continue producing with no further reporting.

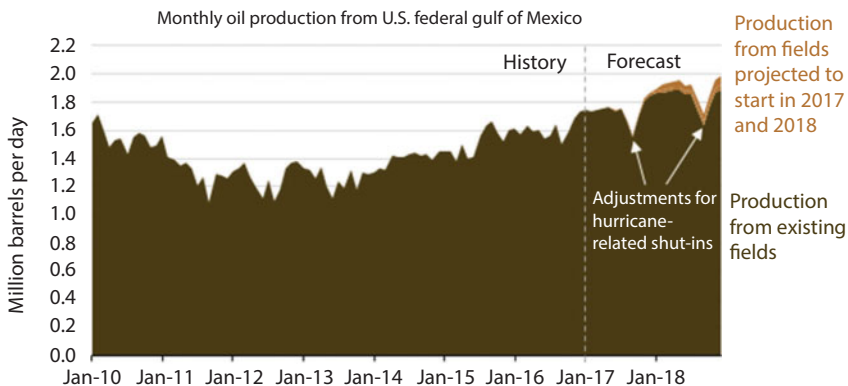

Figure 8.24 Production history of GoM (from IEA, 2017).

MMS allowed continued operation of 30 wells in which the casing pressure was attributed to thermal expansion of annuli fluids. The MMS denied 112 of the requests, preventing normal well operation and requiring the operator to perform remedial work to resolve the problem. Operators withdrew 35 departure requests.

Davies *et al.* (2014) reported more recent data that show that of 15,500 producing, shut in and temporarily abandoned wells in the outer continental shelf of the Gulf of Mexico, 6692 (43%) have sustained casing pressure on at least one casing annulus. Of these incidents, 47.1% occurred in the production strings, 26.2% in the surface casing, 16.3% in the intermediate casing, and 10.4% in the conductor pipe. Sustained casing pressure problems are not restricted to wells in the Gulf of Mexico. It is a problem that can develop in any petroleum basin, worldwide.

Vignes and Aadnøy (2010) examined 406 wells at 12 Norwegian offshore facilities operated by seven companies. Their dataset included producing and injection wells, but not plugged and abandoned wells. Of the 406 wells they examined, 75 (18%) had well barrier issues. There were 15 different types of barrier that failed, many of them mechanical, including the annulus safety valve, casing, cement and wellhead. Issues with cement accounted for 11% of the failures, whilst issues with tubing accounted for 39% of failures.

Analysis of Norwegian Continental Shelf showed that, in 2008, 24% of 1677 wells were reported to have well barrier failures; in 2009, 24% of 1712 wells had well barrier failures; and in 2010, 26% of 1741 wells had well barrier failures. It is unclear whether the same wells were tested in successive years or whether surveys targeted different wells (Vignes, 2011). A study of 217 wells in eight offshore fields was also carried out by SINTEF (Vignes, 2011). Between 11% and 73% of wells had some form of barrier failure, with injectors two to three times more likely to fail than producers (Vignes, 2011). Figure 8.25 shows that cementing problem features prominently whenever annular leak problems are reported.

At the 20th Drilling Conference in Kristiansand, Norway, in 2007, Statoil presented an internal company survey of offshore well integrity (Vignes, 2011). This analysis showed that 20% of 711 wells had integrity failures, issues, or uncertainties (Vignes, 2011). When subdivided into production and injection wells, the survey concluded that 17% of 526 production wells and 29% of 185 injection wells had well barrier failures.

The results of an inspection project carried out by the State Supervision of Mines Netherlands were also reported by Vignes (2011). Their inspections, carried out in 2008, included only 31 wells from a total of 1349 development wells from 10 operating companies. Of those wells, 13% (4 of 31)

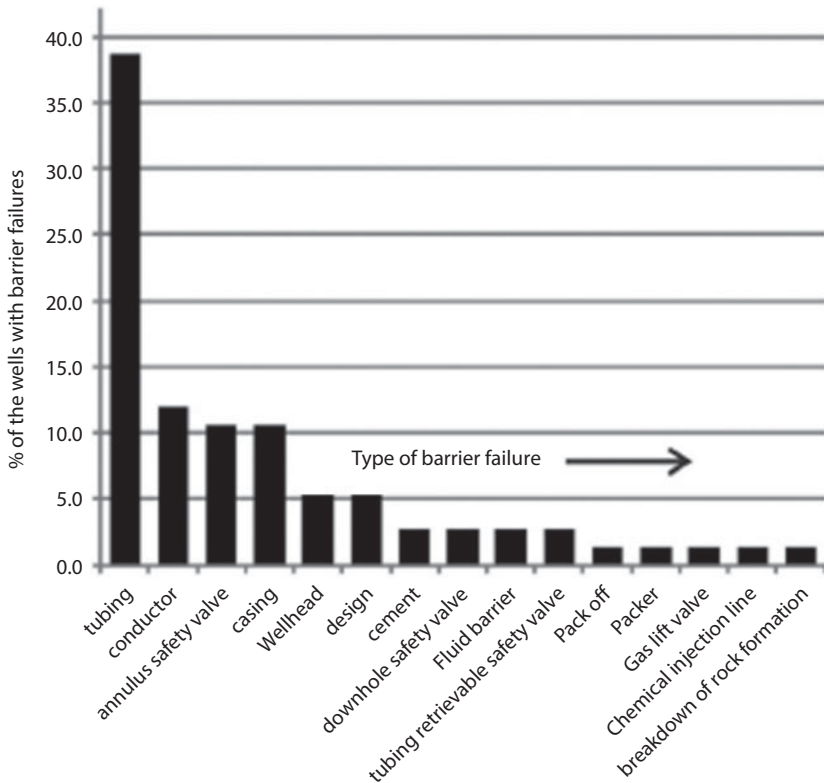

**Figure 8.25** Causes of barrier failures for the 75 (of 406) production and injection wells surveyed in offshore Norway that showed evidence for such failures (from Vignes, 2011).

had well barrier problems; by well type, problems were identified in 4% of the production wells (1 of 26) and 60% of the injection wells (3 of 5).

### 8.3.3 Cases of Good Cement Jobs

Summarizing earlier sections, a good cement job should have the following fundamental features (Mwang'ande, 2016).

1. Theoretical displacement ratio above one, and preferably 1.4 to account for excess volume due to hole over gauge in open hole intervals.
2. Observed TOC may be lower than the planned TOC but this should not be a problem. For example, if there is enough casing overlap filled with cement or present casing is hanged at sea bed, low observed TOC is not a problem.

3. The ratio of observed volume based on CBL or similar tools to pumped volume should be approaching one.
4. Actual displacement efficiency is closer to one.
5. The overall displacement process should not lead to compromised cement.

Mwang'ande (2016) compiled four cases with successful annular filling from the literature that are presented here in order to understand the characteristic features of normal jobs.

### 8.3.3.1 Good Case I

Well Name and Section: 34/10-C-47, section 8 1/2"

Data Source: Statoil A.S.

For well 34/10-C-47, an example of good cement job of the 7" Liner in well section 8 1/2" is presented. Well schematic is shown in Figure 8.26.

Cement loss was anticipated in this zone since it crossed several faults as seen in Table 8.4. Table 8.4 shows faults interpreted from well data and seismic data which are crossed by 8 1/2" well section in Good case I (From Mwang'ande, 2016). It was decided to pump 40 m<sup>3</sup> cement in advance (squeeze in faults to avoid losses) followed by 20 m<sup>3</sup> spacer and finally 30 m<sup>3</sup> foamed cement. As seen in Table 8.5, the three parameters such as theoretical displacement ratio (1.216), actual displacement efficiency (0.988), and fraction of the pumped volume that has actually filled annulus (0.808), all

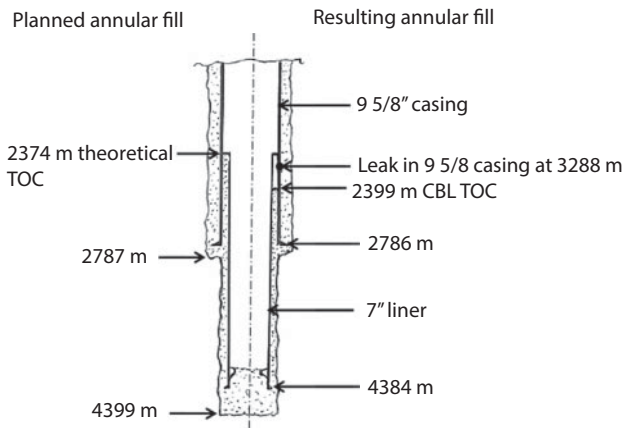

**Figure 8.26** Well configuration and planned and attained TOC of Case I (From Mwang'ande, 2016).



**Table 8.4** Faults interpreted from well data and seismic data

Faults/formation	Measured depth [m]	True vertical depth [m]	Section
Fault S3 (S5/S3)	3210	1975	8 ½"
Fault S3	3425	1999	
Fault S3	3555	1998	
Fault S2 (S5/S3)	3810	2000	
Fault S2	4080	2005	
Fault S2	4150	1999	
Fault S3	4350	1985	

indicate a good cement job. The slight failure in sealing the leak in 9 5/8" casing was cured by squeezing cement into the top of the 7" liner lap.

### 8.3.3.2 Good Case II

Well Name and Section: 2/2-5, section 12 ¼" (9 5/8" csg)

Data Source: AGR Database (Saga Petroleum A.S.)

This 2/2-5 well, an example of good cement job of the 9 5/8" casing in well section 12 ¼" is presented. The well schematic is shown in Figure 8.27.

As seen in Table 8.6, the three parameters; theoretical displacement ratio (1.513), actual displacement efficiency (0.961) and fraction of the pumped volume that has actually filled annulus (0.631), except the last, others indicate a good cement job. A slight fall in observed TOC was detected by CBL logs (planned and observed TOC's were 2070 m MD and 2120 m MD respectively). Since the 9 5/8" casing was hanged at seabed, it is not possible for leak to occur and it was therefore decided not to squeeze the lap and drilling continued to the next section.

### 8.3.3.3 Good Case III

Well Name and Section: 3/4-1, section 17 ½" (13 3/8" casing)

Data Source: AGR Database (Amoco Norway Oil Company)

Well 3/4-1 is an example of a good cement job for the 13 3/8" casing in well section 17 ½". Well schematic is shown in Figure 8.28. As can be seen in Table 8.7, the three parameters; theoretical displacement ratio (1.533), actual displacement efficiency (0.965) and fraction of the pumped volume that has actually filled annulus (0.582), except the last parameter others indicate a good cement job.

Table 8.5 Well data for Case 1 (from Mwang'ande, 2016).

Well name and section: 34/10-C-47, section 8 1/2"						
Data source: Statoil						
Data related to displacement efficiency						
1. Raw data						
Available drilling/cementing parameter	Description/options	OFU		SI		Probability
		Quantity	Unit	Quantity	Quantity	
Bit size	Previous section	12.25	in	0.311		100
Bit size	Present section	8.5	in	0.216		100
ID.Csg	Previous csg(p- 110,53.5 lb) Table 25	8.535	in	0.217		100
ID.Csg	Present (L-80,29 lbft) table 25	7	in	0.178		100
OD.Csg	Present csg			2786.000		100
MD.Csg shoe	Previous csg			4384.000		100
MD Float collar	Previous csg			4367.000		90
MD.Top of cs gliner	Previous csg/liner			2374.000		100
MD Build/Drop.Upper	Its approximate mid-point.Upper is normally csg			2370.000		90
MD Build/Drop.Lowest	Its approximate mid-point.Could well be in the op enhole			2370.000		90
Fm special Expected	2 option: Yes or No→ Yes;(to be stated what speacial)	No				
Fm Fault Expected	2 option: Yes or No→ Yes;could lead coment loss	Yes				
Losses Expected	2 option: Yes or No→ Yes: in true	Yes				
MD.Well	Well TD			4399.000		100
TVD.Well	True Vertical Depth for deviated wells			1982.000		100

Length csg overlap(L1)	Planned Length into previous csg		412.00	100
Length openhole(L2)	Distance from current csg shoe to previous csg shoe		1598.000	100
Length rat hole(LR)	Length of Rat hole(Hole sump)		15.000	100
Length shoe track(hc)	Distance from thrust collar to csg shoe		17.000	100
Well inclination	Average angle of the last hundreds metres	90	0	95
Cement Loss	Loss rate to the formation (% of pump rate)	7	%	75
Frac D – ECD	Narrow pressure margin during cement displacement	1.15	Kg1	80
Well packed-off	2 option: Yes or No <sup>®</sup> Yes: leads to cement loss	No		
Pressure Bleeding High	Pressure drop rate during pressure testing is high	8.7	psj/min	100
MD:TOC	Theoretical		2374.00	90
MD:TOC	From CBL log run (Actual MD of compent)		2399.00	100
Theoretical TOC	Planned Height of cement in annuhis referred from MD.Well		2025.000	90
Observed TOC	ACTUAL Height of cement derived from CBL		2000.000	100
V:Cement (V1)	The pumped volume		30.000	100
<b>2.Calculated/Estimated Results</b>				
V:Cement. Theoretical(v2)	Includes; Annular spaces in L1 & L2, hole sump and shoe track		24.670	
Theoretical dispL ratio(V1/V2)	Ratio of pumped cement volume to theoretical volume		1.216	
Actual dispL efficiency	The ratio of Observed TOC to Theoretical TOC		0,988	
V CBL (V3)	V. Cement Derived from CBL		24.251	
V4	V. Cement that has lost to the formation during pumping (known after CBL run)		5.749	
V3/V1	Fraction of the pumped volume that has actually filled the annulus		0.808	

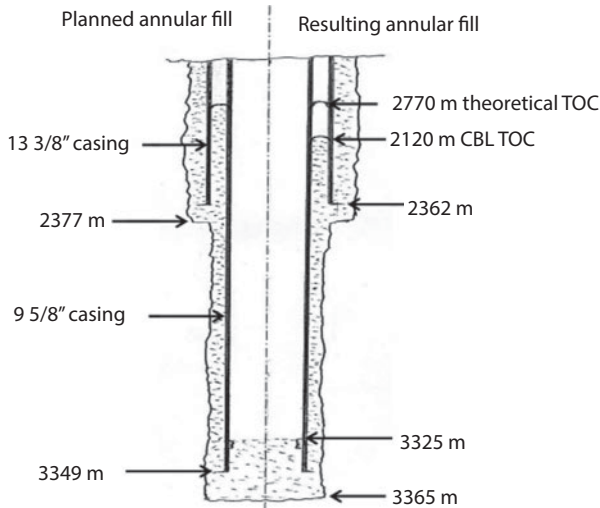

**Figure 8.27** Well configuration, planned and final for Case II.

Although continuous returns were observed throughout the job, material balance of the pit volumes before and after the job indicated a loss of 100 bbl (15.9 m<sup>3</sup>) of drilling fluid. This loss did not affect the cement displacement to a great extent since there was enough pumped volume. A slight fall in observed TOC was detected by CBL logs (planned and observed TOC's were 183 mMD and 230 mMD respectively). This fall in observed TOC proved not to halt the sealing since there was still enough length of cement overlap (see Figure 8.29) and drilling continued to the next section.

#### 8.3.3.4 Good Case IV

Well Sections/Liners: 8 ½" and 6" / 7" and 5 ½"

Data Source: Published literature

A case study from published literature, Hayden *et al.* (2011) is described here in order to show the contrast between good and bad cement bond, and ambiguity of the indicated TOC.

The purpose of cementing in this case study was to isolate the depleted (XX3 Sand) and non-depleted/additional (XX4 Sand) reservoir zones. Interpretation of cement integrity was challenging due to lack of good contrast of the cement bond for the cemented and non-cemented pipe. The resulting top of competent cement seen by normal CBL attenuation logs happened to be in four different levels. This led to uncertainty of whether

Table 8.6 Vital data in case 2 well.

Well name and section: 2/2-5, section 12 1/4" (9, 5/8" Csg)						
Data source: AGR database(saga petroleum A.S)						
Data related to displacement efficiency						
1.Raw data						
Available drilling/ cementing parameter	Description/options	OFU		SI		Probability
		Quantity	Unit	Quantity	Quantity	
Bit size	Previous section	17.5	in	0.445		100
Bit size	Present section	12.25	in	0.311		100
ID.Csg	Previous csg(p-110,72 lb)	12,347	in	0.314		100
ID.Csg	Present (L-110,53 lbf)	8,535	in	0.217		100
OD.Csg	Present csg	9,625	in	0.244		100
MD.Csg shoe	Previous csg			2362.00		100
MD.Csg shoe	Present csg			3349.00		100
MD Float collar	Present csg			3325.00		90
MD Top of csgliner	Present csg liner			89.000		100
MD Build/Drop.Upper	Its approximate mid-point. Upper is normally inside csg					
MD Build/Drop lowest	Its approximate mid-point. Could well be in the open hole. If only one build/drop than upper is also the lowest					
Fm special Expected	2 option: Yes or No→Yes;(to be stated what special)	No				
Fm special Expected	2 option: Yes or No→could lead cement loss	No				
Losses Expected	2 option: Yes or No→Yes: in true	No				
TVD.Well	True Vertical Depth for deviated wells			3364.000		100

(Continued)

Table 8.6 Cont.

Available drilling/ cementing parameter	Description/options	OFU		SI		Probability
		Quantity	Unit	Quantity	Quantity	
Length csg/glement overlap(L1)	Planned length of cement into previous csg			292.000		100
Length open hole(L2)	Distance from cured csg shoe to previous csg shoe			987.000		100
Length rat hole(LR)	Length of Rat hole(Hole sump)			16.000		100
Length. Shoe track(hc)	Distance from thrust collar to csg shoe			24.000		100
Well inclination	Average angle of the last hundreds metres	1.9	0			95
Frac D – ECD	Narrow pressure margin during cement displacement	1.17	Kg/l			80
Well packed-off	2 option: Yes or No→Yes: leads to cement loss	No				
Pressure Bleeding High	Pressure drop rate during pressure testing is high	2.3	Psj/min			90
MD.TOC	Theoretical				2070.000	90
MD.TOC	From CBL log run (Actual MD of competent)				2120.00	90
Theoretical TOC	Planned Height of cement in annulus referred from MD.Well				1295.000	90
Observed TOC	ACTUAL Height of cement derived from CBL				1245.000	100
V.Cement (V1)	The pumped volume(Lead 44+ Tail 6)				60.00	100
<b>2.Calculated/Estimated Results</b>						
V.Cement. Theoretical(v2)	Includes; Annular spaces in L1 & L2, hole sump and shoe track				39,649	
Theoretical dispL ratio (V1/V2)	Ratio of pumped cement volume to theoretical volume				1.513	
Actual dispL efficiency	The ratio of Observed TOC to Theoretical TOC				0,961	
V CBL (V3)	V: Cement Derived from CBL				37,842	
V4	V: Cement that has lost to the formation during pumping (known after CBL run)				22.158	
V3/V1	Fraction of the pumped volume that has actually filled the annulus				0.631	

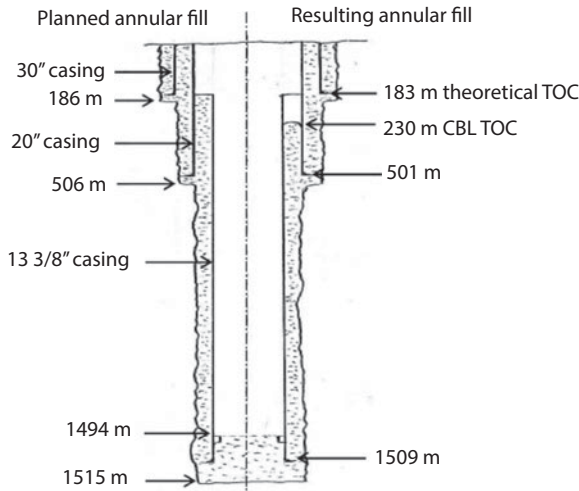

**Figure 8.28** Well configuration, planned and final for Case III.

there was a good or bad cement job in this interval as seen in Figure 8.29. An improved cement integrity evaluation technique helped to clear the doubt by specifying one correct TOC as seen in Figure 8.30. A good contrast between cemented- and free pipe intervals is now clearly seen in Figure 8.30 (Hayden *et al.*, 2011). The technique included Variable Density Logs and Flexural Attenuation map. These concluded that the resulting TOC was enough to offer good zonal isolation (above the XX3 sand) and hence a good cement job for this section was attained.

A good cement job is seen below the indicated TOC whereas above it and all the way to the planned TOC there is a poor cement bond (job). But this was not a problem since the zones were sufficiently isolated by the already attained TOC.

### 8.3.3.5 Good Case V

Well Name and Section: 34/10-37A, Section 12 1/4" (Casing 9 5/8")  
 Data Source: AGR Database (Statoil A.S.), as reported by Mwang'ande (2016).

An example of good cement job for the 9 5/8" casing in well section 12 1/4" is presented. Well schematic is shown in Figure 8.31. The figure shows that pumped cement was low but since there were no huge cement losses to formation, the overall job was good.

Table 8.7 Vital data on Case 3.

Well name and section: 3/4-1,section 17 1/2“(13 3/8” Csg)									
Data source: AGR database(saga petroleum A.S)									
Data related to displacement efficiency									
1.Raw data									
Available drilling/ cementing parameter	Description/options	OFU		SI		Probability			
		Quantity	Unit	Quantity	Unit		Quantity	Unit	Quantity
Bit size	Previous section	17.5	in	0.445		100			
Bit size	Present section	12.25	in	0.311		100			
ID.Csg	Previous csg(X-56,133 lb/ft)	18,73	in	0,445		100			
ID.Csg	Present csg (N-80,72 lbft)	8,535	in	0,217		100			
OD.Csg	Present csg	13,375	in	0,340		100			
MD.Csg shoe	Previous csg			501,000		100			
MD.Csg shoe	Present csg			1494,000		90			
MD Float collar	Present csg			3325.00		90			
MD Top of csgliner	Present csg liner			89,000		100			
MD Build/Drop. Upper	Its approximate mid-point. Upper is normally inside csg								
MD Top of csgliner	Present csg iner			183,000		100			
Fm special Expected	2 option: Yes or No→ Yes;(to be stated what special)	No							
Fm Fault Expected	2 option: Yes or No→could lead cement loss	No							
Losses Expected	2 option: Yes or No→ Yes: in true	No							
MD Well	Well/section TD			1515.000		100			



TVD.Well	True Vertical Depth for deviated wells			1514.950	100
Length csg/cement overlap(L1)	Planned length of cement into previous csg			318.000	100
Length open hole(L2)	Distance from cured csg shoe to previous csg shoe			108.000	100
Length rat hole(LR)	Length of Rat hole(Hole sump)			6.000	100
Length. Shoe track(hc)	Distance from thrust collar to csg shoe			15.000	100
Well inclination	Average angle of the last hundreds metres	0.9	0		95
Cement Loss	Loss rate the formation (% of pump rate)	4	%		85
Fract D-ECD	Narrow pressure margin during cement displacement	1.11	Kgl		
Well packed-off	2 option: Yes or No→Yes: leads to cement loss	No			
Pressure Bleeding H/gh	Pressure drop rate during pressure testing is high	2.7	psi/min		90
MD.TOC	Theoretical			183.000	90
MD.TOC	From CBL log run (Actual MD of compent)			230.000	90
Thoretical TOC	Planned Height of cement in annuhis referred from MD.Well			1332.000	90
Observed TOC	Actual Height of cement derived from CBL			1285.000	100
V.Cement (V1)	The pumped volume(Lead 65 bbl + Tail 229 bbl)	914	bbl	145	100
<b>2.Calculated/Estimated Results</b>					
V.Cement. Theoretical(V2)	Includes; Annular spaces in LI & L2, hole sump and shoe track				
Theoretical dispL ratio(V1/V2)	Ratio of pumped cement volume to theoretical volume				
Actual dispL efficiency	The ratio of Observed TOC to Theoretical TOC				
V CBL (V3)	V. Cement Derived from CBL				
V4	V. Cement that has lost to the formation during pumping (known after CBL run)				
V3/V1	Fraction of the pumped volume that has actually filled the annulus				

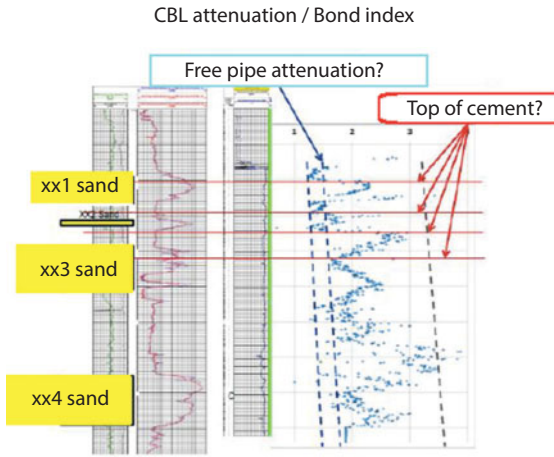

**Figure 8.29** Normal CBL attenuation logs indicating four TOC's due to lack of contrast between cemented and non-cemented pipes. Additional log data are needed to clearly show the specific TOC (Hayden *et al.*, 2011).

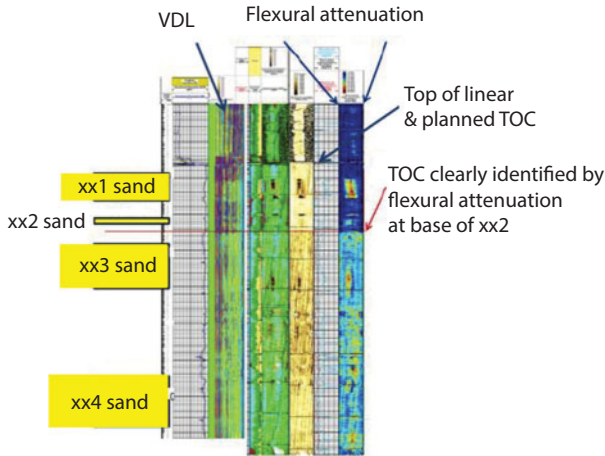

**Figure 8.30** Clear TOC indicated by VDL and Flexural Attenuation map.

Details of the case are found in Table 8.8. This table shows bit sizes, characteristic length and width of various boreholes and other basic features of the well.

Cementing was done by pumping 28.6 m<sup>3</sup> slurry in two stages; 10.7 m<sup>3</sup> lead cement and 17.975.06 m<sup>3</sup> tail cement. Theoretical volume to be displaced was found to be 27.944 m<sup>3</sup>. Under normal circumstances this could be defined as a poor cement job because of low displacement ratio. As seen in Table 8.8, with the exception of theoretical displacement ratio (1.023),

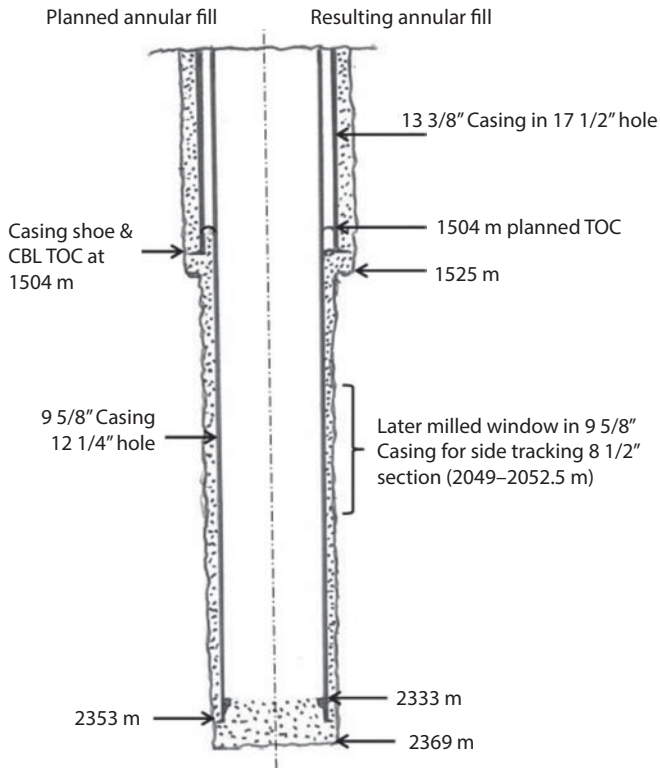

**Figure 8.31** Well schematic; Planned and resulting cement job for well 34/10-37A in Good case V.

actual displacement efficiency (0.951) and fraction of the pumped volume that has actually filled annulus (0.929), indicate a good cement job. The theoretical displacement ratio indicates a bad cement job in this case, but since there was low cement loss and continuous returns were observed throughout the job, and likewise no part of casing was left free then the overall cement job is perceived to be good and successful.

### 8.3.4 Cases of Failed Cement Jobs

In the previous section, we have seen cases of good cement jobs. They were examples of good practices that should help prevent later troubles during the course of cement setting and lifespan of the well. Equally important lessons or perhaps more important ones are learned from failed cement jobs. These jobs tell us what practices should be avoided and what could have done to avert a flawed cement job.

**Table 8.8** Data related to Displacement efficiency for Good Case V.

Well name and section: 34/10-37A section 9 5/8"						
Data source: AGR database(Statoil A.S)						
Data related to displacement efficiency						
1.Raw data						
Available drilling/ cementing parameter	Description/options	OFU		SI		Probability
		Quantity	Unit	Quantity	Quantity	
Bit size	Previous section	17.5	in	0.445	100	100
Bit size	Present section	12.25	in	0.311	100	100
ID.Csg	Previous csg (P-110,72 lb/ft) Table 25	12.347	in	0.314	100	100
ID.Csg	Present csg (P-110,53.5 lb/ft) Table 25	8.535	in	0.217	100	100
OD.Csg	Present csg	9.625	in	0.244	100	100
MD.Csg shoe	Previous csg			1504,000	100	100
MD.Csg shoe	Present csg			2353.000	100	100
MD Float collar	Present csg			2338.000	80	80
MD Top of csgliner	Present csgliner			89.000	100	100
MD Build/Drop.Upper	Its approximate mid-point. Upper is normally inside csg					
MD Top of csgliner	Present csgliner			163.000	100	100
Fm Fault Expected	2 option: Yes or No→Yes; could lead cement loss	No				
Losses Expected	2 option: Yes or No→Yes: in true	Yes				
Fm special Expected	2 option: Yes or No→Yes; leads to disintegrated fm	No				
MD Well	Well/section TD			2369.000	100	100

TVD.Well	True Vertical Depth for deviated wells			2369.950	100
Length csggglement overlap(L1)	Planned length of cement into previous csg			49,000	100
Length op anhole(L2)	Distance from cured csg shoe to previous csg shoe			849,000	100
Length rat hole(LR)	Length of Rat hole(Hole sump)			16,000	100
Length. Shoe track(hc)	Distance from thrust collar to csg shoe			15,000	80
Well inclination	Average angle of the last hundreds metres	1.5	0		100
Coment Loss	Loss rate the formation(% of pump rate)	2	%		90
Fract D-ECD	Narrow pressure margin during cement displacement	1.11	Kg1		
Well packed-off	2 option: Yes or No→Yes: leads to cement loss	No			
MD.TOC	Theoretical			1455,000	90
MD.TOC	From CBL log run (Actual MD of compent)			1500,000	90
Thoretical TOC	Planned Height of cement in annulus referred from MD.Well			914,000	100
Observed TOC	Actual Height of cement derived from CBL			869,000	100
V.Cement (V1)	The pumped volume(Lead 10.7 and Tail= 17.9)			28,600	100
<b>2.Calculated/Estimated Results</b>					
V.Cement. Theoretical(V2)	Includes; Annular spaces in LI & L2, hole sump and shoe track			27,944	
Theoretical dispL ratio(V1/V2)	Ratio of pumped cement volume to theoretical volume			1.023	
Actual dispL efficiency	The ratio of Observed TOC to Theoretical TOC			0,951	
V CBL (V3)	V. Cement Derived from CBL			26,576	
V4	V. Cement that has lost to the formation during pumping (known after CBL run)			2,024	
V3/V1	Fraction of the pumped volume that has actually filled the annulus			0,929	

### 8.3.4.1 Failed Cementing Case 01

Case Name: Lost cement due to hole pack-off

Well Name and Section: 2/1-3, Section 8 ½”

Data Source: AGR Database (BP Petroleum Development Ltd., Norway U.A.)

For well 2/1-3, a case of hole Pack-off leading to lost cement is noticed in well section 8 ½” during cementing operation of the 7” Liner. Well schematic is shown in Figure 8.32. The figure shows the well schematic, planned and attained TOC's for well 2/1-3 in failed case 01. Squeezing was unsuccessful because of pack-off problems in the hole. Analysis and details of the case are found in Table 8.9, Table 8.10, and Table 8.11. Table 8.9 shows bit sizes, characteristic length and width of various boreholes and other basic features of the well. Table 8.10 shows the ontological engineering data, whereas Table 8.11 shows the casual relationship of various problems related to the well.

Cementing was done in two attempts. Slurry mixing problems was the reason for second attempt. Due to the mixing problem, the slurry used in the first attempt was reversed out and dumped. 208 barrels (33.068 m<sup>3</sup>) of slurry was then pumped during the second attempt to cement a theoretical volume of 19.436 m<sup>3</sup>. While pumping cement, the hole packed-off and most of the cement was lost to the formation. This caused pressure build up to 750 psi (51.7 bar) in the well leading to taking in an 11 bbl (1.75 m<sup>3</sup>) kick which was then bled off to zero. After trip in, the mud was then conditioned to 1.71 SG and the well was effectively killed. After cleanup of the casing, CBL was run and showed the zone of lost circulation to be below 9 5/8” casing shoe. Poor or no cementation of the 7” liner lap was also detected. From the CBL, TOC was found to be at 3793 m which means the cement had failed to completely seal even the liner-open hole interval. That is no isolation of zones and which may eventually lead also to corrosion of the liner. Squeezing was unsuccessful because of hole pack-off. The huge loss of cement (18.389 m<sup>3</sup>) led to unsuccessful filling of the annulus (low TOC) as planned and hence poor cement job in this section. As seen in Table 8.9, with exception of theoretical displacement ratio (1.701), actual displacement efficiency (0.558) and fraction of the pumped volume that has actually filled annulus (0.444), both indicate a poor cement job. The pumped volume was enough but losses are the cause of poor cement job.

**Lessons learned:** The issue could have been avoided by:

- a. Ensuring good hole cleaning prior to cement displacement

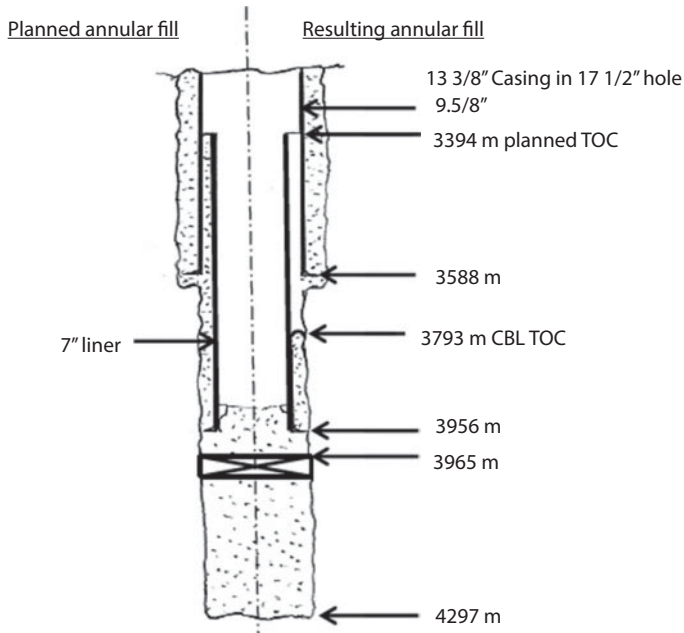

**Figure 8.32** Well schematic; Planned and attained TOC's for well 2/1-3 in failed case 01.

- b. Pumping a certain volume of cement in advance that comprises sufficient lost circulation additives to seal the leaking formation
- c. Pumping rate and pressure could have been reduced and hence avoid pressure build up in the annulus.

### 8.3.4.2 Failed Case 02

Case Name: Lost cement and poor quality cement sheath in washouts

Well Name and Section: 2/1-4, Section 8 1/2"

Data Source: AGR Database (BP Petroleum Development Ltd., Norway U.A.)

For well 2/1-4, a case of lost cement and poor quality of cement sheath is noticed in well section 8 1/2" during cementing operation of the 7" Liner. Well schematic is shown in Figure 8.33. The figure shows the well schematic, planned and attained TOC's for well 2/1-4 in Failed Case 02. Bad cement is seen from 4000 m to 3591 m due washouts. Squeezing was unsuccessful because of compromised cement in this interval. Details of the case are

Table 8.9 Data on failed case 1.

Case name: Lost cement due to hole packoff in well 2/13, section 8 1/2"									
Data source: AGR database(BP Petroleum development Ltd, Norway U.A)									
Data related to displacement efficiency									
1. Raw data									
Available drilling/cementing parameter	Description/options	OFU		SI		Probability			
		Quantity	Unit	Quantity	Unit		Quantity	Unit	Quantity
Bit size	Previous section	12.25	in	0.311		100			
Bit size	Present section	8.5	in	0.216		100			
ID.Csg	Previous csg(N-80 47 lb/ft) Table 25	8.535	in	0.217		100			
ID.Csg	Present csg (XTL-N-80 lb/ft) Table 25	6.094	in	0.155		100			
OD.Csg	Present csg	7	in	0.178		100			
MD.Csg shoe	Previous csg			3588.000		100			
MD.Csg shoe	Present csg			3956.000		100			
MD Top of csgliner	Present csgliner			3394.000		100			
Fm Fault Expected	2 option: Yes or No→Yes; could lead coment loss	NO							
Losses Expected	2 option: Yes or No→Yes: in true	Yes							
MD Well	Well TD			4297.000		100			
TVDD.Well	True Vertical Depth for deviated wells			4295.500		97			
MD Plug	Plugged TD(if well is plugged back)			3965.000		100			
Length cs gcoverlap(L1)	Planned length into previous csg			194.000		100			
Length op anhole(L2)	Distance from curruent csg shoe to previous csg shoe			368.000		100			



Length rat hole(LR)	Length of Rat hole(Hole sump)			341.000	100
Length. Shoe track(hc)	Distance from thurst collar to csg shoe			15.000	80
Well inclination	Aveigo angle of the last hundreds metres	0	0		90
Cement Loss	Loss rate to the formation(% of pump rate)	17	%		70
Fract D-ECD	Narrow pressure margin during cement displacement	0.63	Kg/l		70
Well packed-off	2 option: Yes or No→Yes: leads to cement loss	Yes			
Pressure Bleeding High	Pressure drop rate during pressure testing is high	9.6	Psi'min		70
MD:TOC	Thoretical			3394.000	90
MD:TOC	From CBL log run (Actual)			3793.000	100
Thoretical TOC	Planned Height of cement in annuhis referred from Well TD			903.000	95
Observed TOC	Actual Height of cement derived from CBL			504.000	95
V:Cement (V1)	The pumped volume	208	bbbl	33.068	100
<b>2.Calculated/Estimated Results</b>					
V:Cement. Theoretical(V2)	Includes: Annular spaces in LI & L2, hole sump and shoe track			19.436	
Theoretical dispL ratio(V1/V2)	Ratio of pumped cement volume to theoretical volume			1.701	
Actual displ. efficiency	The ratio of Observed TOC to Theoretical TOC			0.558	
V CBL (V3)	V. Cement Derived from CBL			14.679	
V4	V. Cement that has lost to the formation during pumping (known after CBL run)			18.389	
V3/V1	Fraction of the pumped volume that has actually filled the annulus			0.444	

**Table 8.10** Data related to Ontology engineering for Failed Case 01

Available observation “symptoms(s)(ss)’	Description/options	Basic operator or source	Logic output
Cement V/Theoretical V Low(ss)	When $V_c/V_{c.tc} < 1.5-1.125-1.0$	G36/G38	0
Csg Ann Slot Narrow(ss)	When (bit.Size-OD.Csg) $< 4-3-2$ in(current section)	E11-E14	3
Fm Above Charged(ss)	Increasing reservoir pressure due to natural fracture in the forma- tion or drilling fluid entering the reservoir though later induced fractures	No	0
Fm fault Expected(ss)	Fault intersect may add to the complexity of cementing the well	E18	0
Losses Expected(ss)	Known before drilling	E19	1
Well depth high(ss)	Well TVD $> 2-3-4$ km	G21	3
Well Depth Shallow(ss)	When Well TVD $< 2-1.5-1$ KM	G21	0
Well inclination High(ss)	When Well Incl $> 60$ degrees see WellPlan/EoW	E27	0
Well inclination Low(ss)	When Well Inclination is between 5 and 30 degrees	E27	0
Well inclination Medium(ss)	When Well Inclination is between 30 and 60 degrees	E27	0
Vertical Well(ss)	When Well inclination between 0 and 5 degrees	E27	1
Well length High(ss)	Messure Well lenth $> 3- 4 - 5$ kmMD	G20	2
Well openhole Long “L2+LR”(ss)	If(Md Well-MD Prev.Csg Shoe) $> 0.4-0.75-1$ kmMD	G24+G25	1
Csg Ann Pressure High(s)	Can lead to induced LC	Yes	1
Displacement Pressure High(s)	When;Frac D-ECD $< 1.0-0.5-0$ kG1	E29	1
Displacement Rate High(s)	When leads to pressure build up in the annulus	Yes	1
Losses Seepage(s)	Loss $< 5-3.5-2\%$ of pump rate (+)	E28	0
Losses Serious(s)	Loss $> 5-10-15-2\%$ of pump rate (+)	E28	3
Packoff(s)	Restriction to cement flow caused by accumulated cuttings	E30	1
Pressure Bleeding High(s)	Pressure drop rate $> 5-10-15$ psi/min	E31	1

Table 8.11 Causal relation for failed case 1.

Symptoms/observations	Path strength	Explanation strength	Target error	Probability	Resulting failures
Pack off	1	2.4			
Casing ann. P Hingh	0.8				
Casing ann slot narrow	0.4		Cement Not Sufficiently displaced	0.27	
Well length high	0.2				
<hr/>					
Pack off	1	2.2			
Losses serious	0.8		Cement Shealth Quality low	0.25	Lost cement, Kick and overall cement jop failure
Csg ann slot narrow	0.4				
<hr/>					
Losses serious	1	4.2			
Pack off	0.6				
Pressure bleeding High	0.8				
Displacement Pressure High	0.8		Leak Behind Casing	0.48	
Displacement Rate High	0.8				
Well Openhole long	0.2				
Total		8.8		1.00	

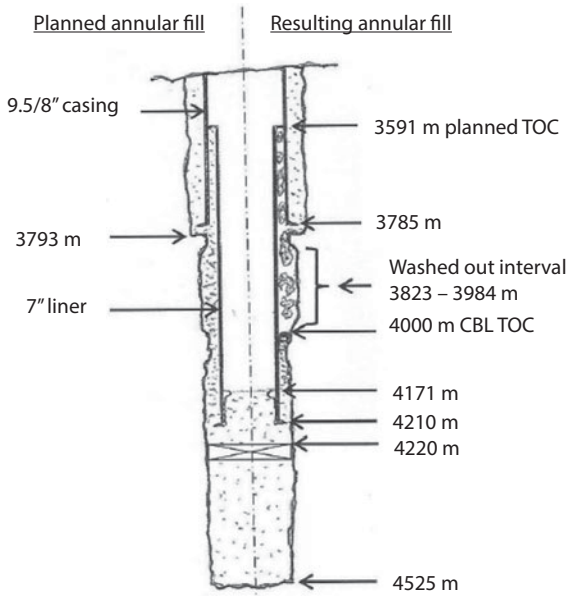

**Figure 8.33** Well schematic; Planned and attained TOC's for well 2/1-4 in Failed Case 02.

found in Tables 8.12, 8.13 and 8.14. Table 8.12 shows bit sizes, characteristic length and width of various boreholes and other basic features of the well. Table 8.13 shows the ontological engineering data, whereas Table 8.14 shows the casual relationship of various problems related to the well.

Cementing was done in two attempts. The first cementing attempt was unsuccessful because of failed air supply at the cementing equipment and the cement for this attempt was circulated out and dumped. A total of 12 hours 15 minutes were lost during the first attempt. A second attempt was initiated. A total of 1241 cubic feet (35.141 m<sup>3</sup>) cement was pumped in the second attempt to cement a theoretical volume of (19.876 m<sup>3</sup>). The second attempt faced severe displacement problems because of the following problems:

1. This section was badly washed out in the interval 3823-3984 m (maximum of 15" by 23" elliptical). The washouts led to poor hole cleaning and bad quality of the cement sheath.
2. Special formation (loose sand) was penetrated in the washed-out interval which led to poor bonding of cement and formation.
3. Displacement pressure was very high (max. 1200 psi). It was twice the pressure used in well 2/1-3 in the same area.

Table 8.12 Vital data of Bad case 2.

Case name: Lost cement and poor quality cement sheath in washouts of well 2/1-4, sec 8 1/2 <sup>p</sup>						
Data source: AGR database(BP Petroleum development Ltd, Norway U.A)						
Data related to displacement efficiency						
1.Raw data						
Available drilling/cementing parameter	Description/options	OFU		SI		Probability
		Quantity	Unit	Quantity	Quantity	
Bit size	Previous section	12.25	in	0.311	100	100
Bit size	Present section	8.5	in	0.216	100	100
ID.Csg	Previous csg(N-80 47 lb/ft) Table 25	8.681	in	0.220	100	100
ID.Csg	Present csg(N-80 29 lb/ft) Table 25	6.184	in	0.157	100	100
OD.Csg	Present csg	7	in	0.178	100	100
MD.Csg shoe	Previous csg			3785.000	100	100
MD.Csg collar	Present csg			4171.000	100	100
MD Top of csgliner	Present csgliner			3591.000	100	100
Fm Fault-Expected	2 option: Yes or No→Yes; could lead cement loss	NO				
Losses Expected	2 option: Yes or No→Yes; in tare	Yes				
Fm Special Expected	2 option: Yes or No→Yes;leads to disintegrated fm	Yes				
MD Well	Well TD			4525.000	100	100
TVD.Well	True Vertical Depth for deviated wells			4524.500	95	95
MD Plug	Plugged TD(if well is plugged back)			4220.000	100	100

(Continued)

Table 8.12 Cont.

Available drilling/cementing parameter	Description/options	OFU		SI		Probability
		Quantity	Unit	Quantity	Unit	
Length openhole(L2)	Distance from current csg shoe to previous csg shoe			425,000		100
Length rat hole(LR)	Length of Rat hole(Hole sump)			315,000		100
Length, Shoe track(hc)	Distance from thrust collar to csg shoe			39,000		100
Well inclination	Average angle of the last hundreds metres	1.3	0			95
Cement Loss	Loss rate to the formation(% of pump rate)	19	%			75
Fract D-ECD low	Narrow pressure margin during cement displacement	0.4	Kg1			80
Well packed-off	2 option: Yes or No→Yes: leads to cement loss	No				
Pressure Bleeding High	Pressure drop rate during pressure testing is high	15	Psi/min			100
MD:TOC	Theoretical					100
MD:TOC	From CBL log run (Actual MD of competent cement)			3591,000		100
Theoretical TOC	Planned Height of cement in annulus referred from MD Well			400,000		100
Observed TOC	Actual Height of cement derived from CBL			934,000		100
V:Cement (VI)	The pumped volume(Lead 270+Tail 971)	1241	Cu ft	525,000		100
2.Calculated/Estimated Results						
V:Cement. Theoretical(V2)	Includes: Annular spaces in LI & L2, hole sump and shoe track					19,876
Theoretical dispL ratio(V1/V2)	Ratio of pumped cement volume to theoretical volume					1.768
Actual displ efficiency	The ratio of Observed TOC to Theoretical TOC					0.562
V CBL (V3)	V. Cement Derived from CBL					14,754
V4	V. Cement that has lost to the formation during pumping (known after CBL run)					20,387
V3/V1	Fraction of the pumped volume that has actually filled the annulus					0.420

Table 8.13 Data related to Ontology engineering for Failed Case 2.

Available observation "symptoms(s)(ss)'	Description/options	Basic opertor or source	Logic output
Cement V/Theoretical V Low(ss)	When Vc/Vc.tc<1.5-1.125-1.0	G38/G40	0
Csg Ann Slot Narrow(ss)	When(bit.Size-OD.Csg<4-3-2 in(current section)	E11-E14	3
Fm Above Charged(ss)	Increasing reservoir pressure due to natural fracture in the formation or drilling fluid entering the reservoir though later induaced fractures	No	0
Fm special Expected(ss)	Formation that leads to washouts(disintegrated wellbore)	E21	1
Fm fault Expected(ss)	Fault intersect may add to the complexity of cementing the well	E19	0
Losses Expected(ss)	Known before drilling	E20	1
Well depth high(ss)	Well TVD>2-3-4 km	G23	3
Well Depth Shallow(ss)	Well TVD<2-1.5-1KM	G23	0
Well inclination High(ss)	When Well Incl>60 degrees see WellPlan/EoW	E29	0
Well inclination Medium(ss)	When Well Inclination between 30 and 60 degrees	E29	0
Well inclination Low(ss)	When Well Inclination is between 5 and 30 degrees	E29	0
Vertical Well(ss)	When Well inclination between 0 and 5 dregress	E29	1
Well length High(ss)	Measurre Well length>3- 4 - 5 kmMD	G22	2
Well openhole Long "L2+LR"(ss)	If(Md Well-MD Prev.Csg Shoe)>0.4-0.75-1 kmMD	G27+G26	1
Csg Ann Pressure High(s)	Can lead to induced LC	Yes	1
Displacement Pressure High(s)	When;Frac D-ECD<1.0-0.5-0 kG1	E29	1
Displacement Rate High(s)	leads to pressure build up in the annulus	Yes	1
Losses Seepage(s)	Loss<5-3.5-2%of pump rate (+)	E30	0
Losses Serious(s)	Loss>5-10-15-2%of pump rate (+)	E30	3
Packoff(s)	Restriction to cement flow caused by accumulated cuttings	E32	1
Pressure Bleeding High(s)	Pressure drop rate>5-10-15 psi/min	E33	1

Table 8.14 Causal relationships of failed case 2.

Symptoms/observations	Path strength	Explanation Strength	Target Error	Probability	Resulting failures
Fm special expected	1	1.6	Wellbore Enlarged	0.27	Lost cement,Kick and overall cement job failure
Well open hole long	0.4				
Displacement Rate high	0.2				
Losses serious	1	2.8	Cement Not Sufficiently displaced	0.19	
Casing ann. P High	0.6				
Csg ann slot narrow	0.8				
Well depth high	0.2				
Well length high	0.2				
Fm special expected	0.6	3	Cement sheath Quality low	0.20	
Well length high	0.4				
Losses expected	0.4				
Losses serious	0.8				
Csg ann slot narrow	0.8				
Pressure bleeding high	1				
Losses serious	0.8				
Csg ann slot narrow	0.8				



Pressure bleeding high	1				Lost cement, Kick and overall cement job failure
Csg ann P. hig	0.6			0.12	
Well open hole long	0.2				
<hr/>					
Losses serious	1				
Well depth high	0.8				
Csg ann slot narrow	0.2				
Casing ann. P High	0.8				
Losses expected	0.6				
Pressure bleeding high	0.6				
Displacement Pressure high	0.8				
Displacement Rate high	0.8				
Well openhole long	0.2				
Total			15		1.00

This led to development of induced fractures and hence loosening cement.

4. Displacement rate was also high (7.5 bbl/min) for this narrow annulus. This led to annular pressure build up. It is stated in EoW report for well 2/1-4 that CBL logs showed good cement bond from 7" liner shoe to 4000 mMD, except from some poor interval 4100–4130 mMD. Bad cements were seen from 4000 mMD to liner overlap at 3590 mMD which might be because of washouts.

### 8.3.4.3 Failed Case 03

Case Name: Risk of casing corrosion due to insufficient pumped cement volume and loss of cement to formation

Well Name and Section: 2/2-2, Section 17 ½"

Data Source: AGR Database (Saga Petroleum A.S.)

For well 2/2-2, a case of low TOC (casing exposed to formation) is noticed in well section 17 ½" during cementing operation of the 13 3/8" casing. Well schematic is shown in Figure 8.34. Details of the case are found in Table 8.15, Table 8.16 and Table 8.17. Table 8.15 shows bit sizes, characteristic length and width of various boreholes and other basic features of the well. Table 8.16 shows the ontological engineering data, whereas Table 8.17 shows the casual relationship of various problems related to the well.

Cementing was done by pumping cement volume of 4124 cu.ft, (87.226 m<sup>3</sup>) in two stages. 3549 cu.ft (75.06 m<sup>3</sup>) lead cement and 575 cu.ft (12.16 m<sup>3</sup>) tail cement. Theoretical volume to be displaced was found to be 84.872 m<sup>3</sup>. This led to poor displacement ratio. It is stated that CBL log was run and indicated the TOC to be at 1220 mMD while the planned TOC was anticipated to 706 mMD. The low observed TOC left the casing free (not cemented) and exposed to formation, leading to a high risk of casing corrosion which can develop a hole on it. Poor cement job in this section was due to:

1. Insufficient pumped cement volume. Pumped 87.226 m<sup>3</sup> cement to fill 84.872 m<sup>3</sup> annular space
2. High displacement pressure (2500 psi or 172 bar) which led to losses of both cement and mud during displacement as seen in Table 8.15, the three parameters; theoretical displacement ratio (1.028), actual displacement efficiency (0.592) and fraction of the pumped volume that has actually filled annulus (0.593), all indicate a poor cement job.

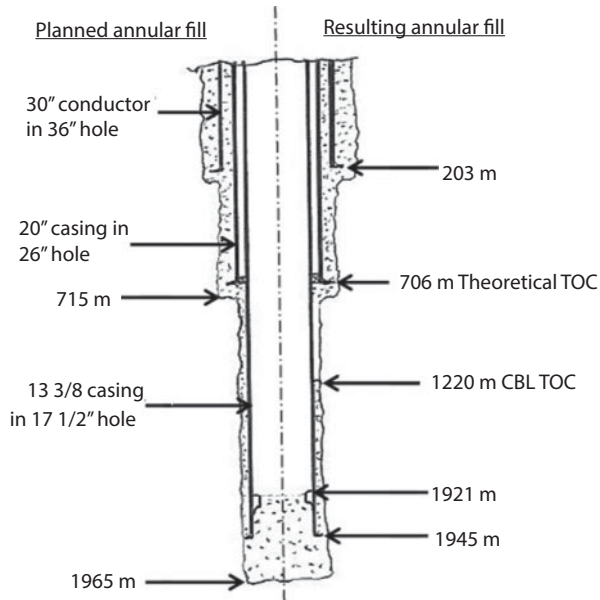

**Figure 8.34** Well configuration as planned and actual.

The situation could have been avoided by:

- a. Increasing the volume of pumped cement
- b. Reducing displacement rates
- c. Reducing displacement pressure

#### 8.3.4.4 Failed Case 04

Case Name: Poor cement bond and Poor cement coverage in inclined well section

Well Name and Section: 7/12-3A, Section 8 ½"

Data Source: AGR Database (BP Petroleum development of Norway A/S)

A case of poor cement-bond and sheath (annular coverage) is noticed in inclined well section 8 ½" during cementing operation of the 7" Liner. Well schematic is shown in Figure 8.35. Tables 8.18, 8.19, and 8.20 contain details about the well. Table 8.18 shows bit sizes, characteristic length and width of various boreholes and other basic features of the well. Table 8.19 shows the ontological engineering data, whereas Table 8.20 shows the casual relationship of various problems related to the well.

Cementing was done in a single stage by pumping 504 ft<sup>3</sup> (14.272 m<sup>3</sup>) cement slurry to fill a theoretical volume of 11.083 m<sup>3</sup>. It is stated that CBL/

**Table 8.15** Data related to Displacement efficiency for failed Case 0.3.

Case name: Risk of csg corrosion due to insufficient pumped v.cement in well 2/2-2, sect. 17 ½"									
Data source: AGR database(Saga Petroleum A.S)									
Data related to displacement efficiency									
1.Raw data									
Available drilling/cementing parameter	Description/options	OFU			SI			Probability	
		Quantity	Unit	Quantity	Quantity	Quantity			
Bit size	Previous section	26	in	0.660			100		
Bit size	Present section	17.5	in	0.445			100		
ID.Csg	Previous csg(X-52,133 Jb/ft) Table 25	18,73	in	0.476			100		
ID.Csg	Present csg(N-80 72 Jb/ft) Table 25	12.347	in	0.314			100		
OD.Csg	Present csg	13.375	in	0.340			100		
MD.Csg shoe	Previous csg			706.000			100		
MD.Csg Shoe	Present csg			1945.000			100		
MD. Float colar	Present csg			1921.000			100		
MD Top of csgrliner	Present csgrliner			90.600			100		
Fm Fault Expected	2 option: Yes or No→Yes; (to be stated what speacial)	NO							
Losses Expected	2 option: Yes or No→could lead cement loss	NO							
Losses Expected	2 option: Yes or No→Yes: in tare	Yes							
Fm Special Expected	2 option: Yes or No→Yes;leads to disintegrated fm	Yes							
MD Well	Section TD					4525.000	100		
TVD.Well	True Vertical Depth for section wells					4524.500	95		

Length cs goverlap(LI)	Planned length into previous csg(no cementation of lap)		1964.940	100
Length openhole(L2)	Distance from curruent csg shoe to previous csg shoe		1239.000	100
Length rat hole(LR)	Length of Rat hole(Hole sump)		425.000	100
Length. Shoe track(hc)	Distance from thrust collar to csg shoe		24.0000	100
Well inclination	Average angle of the last hundreds metres	0.75	0	100
Cement Loss	Loss rate to the formation(% of pump rate)	12	%	75
Fract D-ECD	Narrow pressure margin during cement displacement	0.87	Kg1	70
Well packed-off	2 option: Yes or No→Yes: leads to cement loss	NO		
MD.TOC	Theoretical		706.000	95
Pressure Bleeding High	Pressure drop rate during pressure testing is high	15	Psi/min	100
MD.TOC	From CBL log run (Actual)		1220.000	100
Theoretical TOC	Planned Height of cement in annulus referred from MD Well		1259.000	95
Observed TOC	Actual Height of cement derived from CBL		745000	95
V:Cement (VI)	The pumped volume(Lead 3549+Tail 575 cu fit)	4124	Cu ft	100
<b>2. Calculated/Estimated Results</b>				
V:Cement. Theoretical(V2)	Includes; Annular spaces in LI & L2, hole sump and shoe track		84.872	
Theoretical dispL ratio(V1/V2)	Ratio of pumped cement volume to theoretical volume		1.028	
Actual dispL efficiency	The ratio of Observed TOC to Theoretical TOC		0.592	
V CBL (V3)	V. Cement Derived from CBL		51.718	
V4	V. Cement that has lost to the formation during pumping (known after CBL run)		35.508	
V3/V1	Fraction of the pumped volume that has actually filled the annulus		0.593	

Table 8.16 Data related to Ontology engineering for Failed Case 03.

Available observation “symptoms(s)(ss)’	Description/options	Basic operator or source	Logic output
Cement V/Theoretical V Low(ss)	When $V_c/V_{tc} < 1.5 - 1.125 - 1.0$	G36/G38	2
Fm Fault-Expected(ss)	Fault- intersect may add to the complexity of cementing the well	E20	0
Fm special-Expected(ss)	Here it will be defined in particular case	E20	0
Losses-Expected(ss)	Known before drilling	E21	1
Well Depth high(ss)	Well TVD > 2-3-4 km	G23	0
Well Depth Shallow(ss)	When Well TVD < 2-1.5-1 KM	G23	1
Well inclination High(ss)	When Well Incl > 60 degrees see WellPlan/EoW	E28	0
Vertical Well(ss)	When Well inclination between 0 and 5 degrees	E28	1
Well Depth Shallow(ss)	Well TVD < 2-1.5-1 KM	G23	0
Well inclination Low(ss)	When Well Inclination is between 5 and 30 degrees	E28	0
Well inclination Medium(ss)	When Well Inclination between 30 and 60 degrees	E28	0
Well inclination Low(ss)	When Well Inclination is between 5 and 30 degrees	E29	0
Well length High(ss)	Measure Well length > 3- 4 – 5 kmMD	G22	0
Well openhole Long “L2+LR”(ss)	If(Md Well-MD Prev.Csg Shoe) > 0.4-0.75- 1 kmMD	G25+G26	3
Csg Ann P High(s)	Can lead to induced LC	Yes	1
Displacement Pressure High(s)	When;Frac D-ECDD < 1.0-0.5-0 kG1	E30	1
Displacement Rate High(s)	When leads to pressure build up in the annulus	Yes	1
Losses Seepage(s)	Loss < 5-3.5-2% of pump rate (+)	E29	0
Losses Serious(s)	Loss < 5-3.5-2% of pump rate (+)	E29	0
Packoff(s)	Restriction to cement flow caused by accumulated cuttings	E31	0

Table 8.17 Causal relation for failed case 3

Symptoms/observations	Path strength	Explanation strength	Target error	Probability	Resulting failures
Cement V/Theoretical V Low	1	3.8	Cement Not Sufficiently displaced	0.51	Lost cement and insufficient annular fill leading to risk of casing corrosion
Losses expected	0.8				
Casing ann P high	0.4				
Losses serious	0.8				
Well Openhole long	0.6				
Well length high	0.2				
Losses serious	1	3.6	Leak behind Casing	0.49	
Losses expected	0.8				
Displacement Pressure High	0.8				
Displacement Rate High	0.8				
Well Openhole long	0.2				
Total		7.4		1.00	

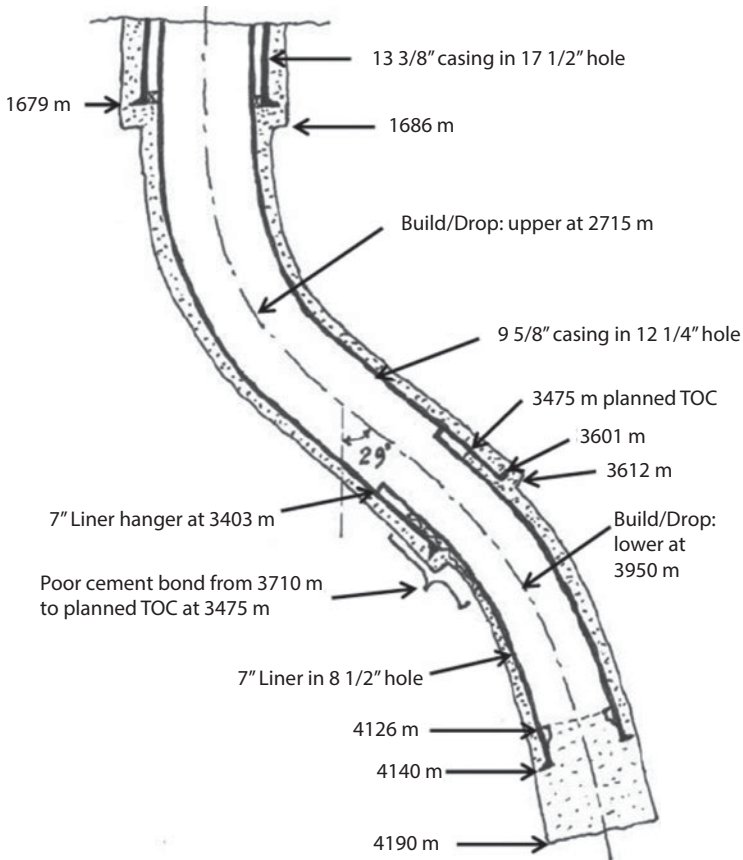

**Figure 8.35** Well schematic; showing resulting cement job (Poor cement bond and coverage) in narrow annulus of section 8 1/2" for an inclined well 7/12-3A of Failed Case 04.

VDL logs were run and indicated inadequate cement coverage in the lower side of dropping-off section. This led to poor cement bond with the formation and liner. The poor bonding on the drop-off section happened from 3710 mMD (Observed TOC) to the liner lap. Squeezing was only successful on the liner lap and some perforated parts of the drop-off section. Poor cement job in this section was caused by:

1. Well inclination of 29° which led to casing decentralization in this section (narrow annulus in a low side of drop-off section).
2. Drop-off section inside the open hole.



**Table 8.18** Data related to Displacement efficiency for Failed Case 04.

Data source: AGR database(BP petroleum development of Norway U.A)						
Data related to displacement efficiency						
1.Raw data						
Available drilling/cementing parameter	Description/options	OFU		SI		Probability
		Quantity	Unit	Quantity	Quantity	
Bit size	Previous section	12.25	in	0.311	100	100
Bit size	Present section	8.5	in	0.216	100	100
ID.Csg	Previous csg(N-80 47 lb/ft) Table 25	8.681	in	0.220	100	100
ID.Csg	Present csg(N-80,32 lb/ft) Table 25	6.094	in	0.155	100	100
OD.Csg	Present csg(N-80,32 lb/ft Table 25)	6.094	in	0.155	100	100
MD.Csg shoe	Previous csg			3601.000	100	100
MD.Csg shoe	Previous csg			4140.00	100	100
MD.Csg collar	Present csg			4126.000	90	
MD Top of csgliner	Present csgliner			3403.000	100	
MD Build/Drop Lower	Average depth of start and end of the deviation			3950.000		
Fm Fault Expected	2 option: Yes or No→ Yes; could lead cement loss	NO				
Losses Expected	2 option: Yes or No→ Yes; in tare	Yes				
Fm Special Expected	2 option: Yes or No→ Yes;leads to disintegrated fm	No				
MD Well	Well TD			4190.000	100	100
TVD.Well	True Vertical Depth for deviated wells			4002.600	100	100

(Continued)

Table 8.18 Cont.

Available drilling/cementing parameter	Description/options	OFU		SI		Probability
		Quantity	Unit	Quantity	Unit	
Length openhole(L2)	Distance from curruent csg shoe to previous csg shoe			539,000		100
Length rat hole(LR)	Length of Rat hole(Hole sump)			50,000		100
Length. Shoe track(hc)	Distance from thrust collar to csg shoe			14,000		100
Well inclination	Average angle of the last hundreds metres	29	0			100
Cement Loss	Loss rate to the formation(% of pump rate)	14	%			75
Fract D-ECD low	Narrow pressure margin during cement displacement	0.4	Kgl			80
Well packed-off	2 option: Yes or No→Yes: leads to cement loss	No				
Pressure Bleeding High	Pressure drop rate during pressure testing is high	11	Psi/min			100
MD.TOC	Thoretical			3475,000		100
MD.TOC	From CBL log run (Actual MD of competent cement)			3710,000		80
Thoretical TOC	Planned Height of cement in annuhis referred from MD Well			715,000		100
Observed TOC	Actual Height of cement derived from CBL			480,000		100
V.Cement (V1)	The pumped volume(Lead 270+ Tail 971)	504	Cu ft	14,272		100
<b>2.Calculated/Estimated Results</b>						
V.Cement. Theoretical(V2)	Includes: Annular spaces in LI & L2, hole sump and shoe track					11.083
Theoretical disp.L. ratio(V1/V2)	Ratio of pumped cement volume to theoretical volume					1.288
Actual disp.L. efficiency	The ratio of Observed TOC to Theoretical TOC					0.671
V CBL (V3)	V. Cement Derived from CBL					7.156
V4	V. Cement that has lost to the formation during pumping (known after CBL run)					7.116
V3/V1	Fraction of the pumped volume that has actually filled the annulus					0.501

Table 8.19 Data related to Ontology engineering for Failed Case 04.

Available observation “symptoms(s)(ss)’	Description/options	Basic operator or source	Logic output
Cement V/Theoretical V Low(ss)	When $V_c/V_c.tc < 1.5-1.125-1.0$	E11-E14	3
Csg Ann Slot Narrow(ss)	When $V_c/V_c.th < 4-3-2$ in(current section)	E11-E14	3
Build/Drop Section Inside Csg(ss) “No cement completion”	When (MD Prev. Csg Shoe)- MD Build/drop upper>0	G15-G19	1
Build/Drop section inside openhole(ss)”Csgliner decentralized”	When (MD Prev Csg shoe MD build drop lower <0; When inside openhole leads to csg decentralization)	G15-G20	1
Fm Above Charged(ss)	Increasing reservoir pressure due to natural fracture in the formation or drilling fluid entering reservoir through later induced fracture	NO	0
Fm Special Expected	Formation that leads to washouts(disintegrated wellbore)	E23	0
Fm Fault EXPECTED(SS)	Fault intersect may add to the complexity of cementing the well	E21	0
Losses Expected(ss)	Know before drilling	E22	1
Well Depth Shallow(ss)	Well TVD<2-1.5-1 KM	G25	0

(Continued)

Table 8.18 Cont..

Available observation "symptoms(s)(ss)"	Description/options	Basic operator or source	Logic output
Well inclination Low(ss)	When Well Inclination is between 5 and 30 degrees	E30	0
Well inclination Medium(ss)	When Well Inclination between 30 and 60 degrees	E30	0
Well inclination Low(ss)	When Well Inclination is between 5 and 30 degrees	E30	0
Well length High(ss)	Measure Well length>3- 4 – 5 kmMD	G22	0
Well openhole Long "L2+LR"(ss)	If(Md Well-MD Prev.Csg Shoe)>0.4-0.75-1 kmMD	G27+G28	1
Csg Ann P High(s)	Can lead to induced LC	Yes	1
Displacement Pressure High(s)	When;Frac D-ECDD<1.0-0.5-0 kG1	E31	1
Displacement Rate High(s)	When leads to pressure build up in the annulus	Yes	1
Losses Seepage(s)	Loss<5-3.5-2%of pump rate (+)	E31	2
Losses Serious(s)	Loss<5-3.5--2%of pump rate (+)	E31	0
Packoff(s)	Restriction to cement flow caused by accumulated cuttings	E34	2
Pressure Bleeding High(s)	Pressure drop rate>5-10-15 psi/min	E34	2

Table 8.20 Causal relation for failed case 04.

Symptoms/observations	Path strength	Explanation strength	Target error	Probability	Resulting failures
Cement V/Theoretical V low	1				
Losses serious	0.6				
Casing ann P high	0.6				
Casing ann slot narrow	0.6	4.2	Cement Not Sufficiently displaced	0.28	
Losses expected	0.2				
Displacement Pressure High	0.4				
Well inclination	0.8				
Casing Decentralized	1				
Cement V/Theoretical V low	0.8				
Well inclination	0.8				
Build/Drop section inside openhole	0.8	5.4	Cement Sheath Quality low	00.36	Poor-cement bond and Poor cement coverage in inclined well section
Well openhole long(L2+LR)	0.2				
Displacement pressure high	0.8				
Csg ann slot narrow	1				
Well depth high	0.2				
Csg ann slot narrow	0.8				
Losses serious	0.8				
Csd ann P high	1				
Losses expected	0.2	5.2	Leak Behind Casing	0.35	
Pressure bleeding high	0.6				
Displacement Pressure High	0.8				
Well openhole long	0.8				
Total		14.8		1.00	

3. High displacement pressure which led to build up of high pressure in the annulus and eventually loss of slurry to formation.

It is stated that the same problem happened on the top side of buildup of 12 ¼" section of the same well as seen in Figure 8.35. As seen in Table 8.18, the three parameters; theoretical displacement ratio (1.288), actual displacement efficiency (0.671) and fraction of pumped volume that has actually filled annulus (0.501), all indicate a poor cement job.

The situation could have been avoided by:

- a. Increasing number of casing centralizers to withstand bending resistance (forces) of the casing string
- b. Reducing displacement pressure
- c. Good well design to reduce or avoid high inclinations

## 8.4 Summary

In this chapter, cementing operations are discussed with focus on failures that lead to casing problems. Knowledge of well cementing operations was enhanced through the analysis of both good and poor cement jobs. A number of case studies of both success and failure supplements the discussion and prepares one with the best cementing practices to be implemented in the field. Overall, it is recommended to have a custom designed cement job formulated rather than relying solely on standards, as standards are often inadequate in preventing disastrous outcomes.

## References

- Amanullah, M. and A.K. Banik, A.K., 1987, A New Approach to Cement Slurry Calculation, Document ID SPE-17018-MS, Society of Petroleum Engineers Publication.
- AP, 2010, Bad cement jobs plague offshore oil rigs, May 24, available at: [http://www.nola.com/news/gulf-oil-spill/index.ssf/2010/05/bad\\_cement\\_jobs\\_plague\\_offshor.html](http://www.nola.com/news/gulf-oil-spill/index.ssf/2010/05/bad_cement_jobs_plague_offshor.html)
- AP, 2010, Bad cement jobs plague offshore oil rigs, May 24, available at: [http://www.nola.com/news/gulf-oil\\_spill/index.ssf/2010/05/bad\\_cement\\_jobs\\_plague\\_offshor.html](http://www.nola.com/news/gulf-oil_spill/index.ssf/2010/05/bad_cement_jobs_plague_offshor.html)
- API, 2004, API Specification no. 10A.

- Bourgoyne, A.T. Jr., Chnevert, M.E. and Millheim, K.K. *et al.* 1986. *Applied Drilling Engineering*, Vol. 2, 330-339. Richardson, Texas: Textbook series, SPE.
- Darley, H.C.H., Gray, G.R., 1988. *Composition and Properties of Drilling and Completion Fluids*, fifth ed. Butterworth-Heinemann, Houston.
- Davies, R.J. *et al.*, 2014, Oil and gas wells and their integrity: Implications for shale and unconventional resource exploitation, *Marine and Petroleum Geology* 56 (2014) 239–254.
- Eberhardt, J & Jr, Joseph. (2004). Gulf of Mexico Cement Packer Completions Using Liquid Cement Premix. 10.2523/90841-MS.
- Francis, A.J. (1977) *The Cement Industry 1796–1914: A History*, David & Charles, 1977, ISBN 0-7153-7386-2.
- Harder, C., Carpenter, R., Wilson, W., Freeman, E., Payne, H., 1992, Surfactant/cement blends improve plugging operations in oil-base muds. SPE/IADC Drill. Conf. 18–21.
- IEA, 2017, Gulf of Mexico crude oil production, already at annual high, expected to keep increasing, April 12.
- Jakobsen, J., Sterri, N., Saasen, A., Aas, B., Kjosnes, I., & Vigen, A. (1991), Displacements in eccentric annuli during primary cementing in deviated Wells, SPE-21686-MS, Paper presented at the SPE Production Operations Symposium, Oklahoma, 7–9 April.
- Kodur, V., 2014, Properties of Concrete at Elevated Temperatures, ISRN Civil Engineering, Volume 2014 (2014), Article ID 468510, 15 pages.
- Li, Z., *et al.*, 2016, Contamination of cement slurries with oil based mud and its components in cementing operations, *J. Natural Gas Science and Engineering* 29, 160–168.
- Matanovic, D., Vaurina-Medjimurec, N., and Simon, K., 2014, *Risk Analysis for Prevention of Hazardous Situations in Petroleum and Natural Gas Engineering*, Hershey, PA: IGI Global.
- Mian, M. A. (1992). *Petroleum engineering handbook for the practicing engineer* (Vol. 1). Oklahoma: PennWell Books.
- Nelson, E.B., Guillot, D., 2006, *Well Cementing*, Schlumberger, Sugar Land.
- Norsok Standard, 2018, available at <http://www.standard.no/pagefiles/1315/d-010r3.pdf>, accessed January 18, 2018.
- O'Neill, E., & Tellez, L. E. (1990). New slurry mixer improves density control in cementing operations, SPE-21130-MS, Paper presented at the SPE Latin America Petroleum Engineering Conference, Rio de Janeiro, 14–19 October.
- Peternell Carballo, A. G., Dooply, M. I., Leveque, S., Tovar, G., & Horkowitz, J. (2013). Deepwater Wells Top-hole Cement Volume Evaluation using Innovative Hole Size inversion from Logging While Drilling Propagation Resistivity Measurements. Paper presented at the SPE Annual Technical Conference and Exhibition, Louisiana, 30 September – 2 October.
- Sauer, C., & Landrum, W. (1985). Cementing-A Systematic Approach. *Journal of Petroleum technology*, 37(12), 2,184-182,196.

- Skalle, P., 2014a, *Pressure control during oil well drilling* (5th ed.). Trondheim: BookBoon.
- Skalle, P., 2014b, *Drilling fluid engineering* (5th ed.). Trondheim: Bookboon.
- Smith, R. (1984). Successful primary cementing can be a reality. *Journal of Petroleum Technology*, 36(11), 1851-58.
- Smith, T. and Ravi, K. (1991). Investigation of drilling fluid properties to maximize cement displacement efficiency, SPE-22775-MS, Paper presented at the SPE Annual Technical Conference and Exhibition, Dallas, 6–9 October.
- Soares, A. *et al.*, 2017, Cement slurry contamination with oil-based drilling fluids. *Journal of Petroleum Science and Engineering*. 158. 10.1016/j.petrol.2017.08.064.
- Soares, A.A., 2017, Cement slurry contamination with oil-based drilling fluids, *J. Pet. Sci. Eng.*, vol. 158, 433–440.
- Vignes, B., Aadnøy, B.S., 2010. Well-integrity issues offshore Norway. SPE 112535. *SPE Production & Operations*, Volume 25, Issue 02, May.
- Vignes, B., 2011. Contribution to Well Integrity and Increased Focus on Well Barriers from a Life Cycle Aspect (PhD thesis). University of Stavanger.
- Wu, Q. *et al.*, 2017, Advanced distributed fiber optic sensors for monitoring real-time cementing operations and long term zonal isolation, *J. Pet. Sci. Eng.*, 158: 479–493.
- Crook, R.J., 2001, Eight steps ensure successful cement jobs, *Oil and Gas Journal*, July 2.
- Hartog, J.J., Davies, D.R., Stewart, R.B., 1983, An integrated approach for successful primary cementations, *J. Pet. Technol.*, Vol. 35(10).
- Heathman, J., Wilson, J.M., Cantrell, J. H., 1999, WETTABILITY-1: New test procedures optimize surfactant blends, *Oil and Gas Journal*, Oct. 2.
- Hayden, R., Russell, C., Vereide, A., Babasick, P., Shaposhnikov, P., & May, D. (2011), Case studies in evaluation of cement with wireline logs in a deep water environment, Paper presented at the SPWLA 52nd Annual Logging Symposium, Colorado, 14–18 May.



# 9

## Wellbore Instability Problems

### 9.0 Introduction

Any drilling process creates an imbalance to the massive rock fluid system that has been intact for millions of years. It is expected that such man-made intervention will encounter resistance from the rock. In engineering terms, it means any wellbore drilled will become subject to instability. In order to be able to produce from underground, engineers must find a tactic to counter this resistance. The process of wellbore stability is the prevention of brittle failure or plastic deformation of the rock surrounding the wellbore due to mechanical stress or chemical imbalance. Borehole stability is a continuing problem which results in substantial yearly expenditures by the petroleum industry (Hossain and Al-Majed, 2015). Borehole stability technology includes chemical as well as mechanical methods to maintain a stable borehole, primarily during the drilling process but eventually for the purpose of maintaining stability throughout the well lifespan. Borehole instability comes from the fact that any drilling operation (e.g., drilling fluid) contains many complex chemical systems all of which are reactive with each other and the native rock and fluid system. The primary purpose of

drilling fluids is to create a hole and maintain it throughout the production period. This can be carried out with the subsequent subtasks: (i) carrying cuttings out of the hole, (ii) cleaning the bit, cooling and lubricating the bit, (iii) providing buoyancy to the drillstring, (iv) controlling formation fluid pressures, (v) preventing formation damage, and (vi) providing borehole support and chemical stabilization.

Borehole failures are an increasing concern due to an extraordinary rise in drilling activities during last few decades, first because of horizontal wells, then with the expansion of unconventional reservoirs. Both applications meant an exposure to unique geological environments that are far more challenging than what used to be the norm in the past. At present, unconsolidated or poorly consolidated sediments, shales, complex reservoir geometries, naturally fractured reservoirs, and overpressured reservoirs are common sites and they are also vulnerable to wellbore instability.

Wellbore instability can trigger numerous problems during the drilling process as well as throughout the life of the well. The causes of this kind of problems are often classified into: (i) mechanical failure caused by in-situ stresses (for example, failure of the rock around the hole because of high stresses, low rock strength, or inappropriate drilling practice); (ii) erosion caused by fluid circulation; or (iii) chemical effects, which arise from damaging interaction between the rock, generally shale, and the drilling fluid.

The general framework for prevention and remediation of borehole instability lies within the succeeding issues: (i) *Rock-fluid interaction*: A better understanding of this coupled phenomenon may lead to design of greater penetration rates, accurate trajectory, and overall hole stability; (ii) *Flow balance measurements*: Unexpected loss of drilling fluids can lead to catastrophic failures; hence, any advanced warning, especially in geothermal environments, will be beneficial. Also, the development of drilling fluids that result in zero fluid loss, no matter what the formation characteristics, would be a breakthrough; and (iii) *Air-based systems*: Such systems could decrease formation damage and address some of the environmental concerns, provided dust can be adequately controlled. This is in line with a zero-waste engineering scheme that has become the hallmark of sustainable petroleum practices.

## 9.1 Problems Related to Wellbore Instability and their Solutions

Wellbore instability is one of the most important problems that engineers encounter during drilling. The causes of wellbore instability are

often classified into either mechanical (for example, failure of the rock around the hole because of high stresses, low rock strength, or inappropriate drilling practice) or chemical effects which arise from damaging interaction between the rock, generally shale, and the drilling fluid. Often, field instances of instability are a result of a combination of both chemical and mechanical. This problem might cause serious complication in the well and in some cases, can lead to expensive operational problems. The increasing demand for wellbore stability analyses during the planning stage of a field arise from economic considerations and the increasing use of deviated, extended reach and horizontal wells.

Another way to look at the problem of wellbore instability is to consider the fact that some sources are natural, meaning inherent to the formation that is being drilled into, whereas others are related to drilling activities, which are obviously controllable by the driller. Unexpected or unknown behavior of rock is often the cause of drilling problems, resulting in an expensive loss of time, sometimes in a loss of part or even whole borehole.

One of the major difficulties associated with tackling wellbore instability problems is the fact that in many cases the section of an optimal strategy to prevent or mitigate the risk of wellbore collapse might compromise one or more of the other elements in the overall well design, e.g., drilling rate of penetration, the risk of differential sticking, hole cleaning ability, or formation damage. In other words, wellbore stability can be maintained only at the expense of other factors that are desirable, which means that an optimum strategy needs to be developed. In the end, it boils down to optimizing the mud density, chemistry, rheology, the selection of filter cake building additives, and possibly temperature. Sensitivity studies can also reveal if there is any additional risk due to the selected well trajectory and inclination.

### 9.1.1 Causes of Wellbore Instability

As stated earlier, the drilling process being invasive of the natural state of the subsurface, the wellbore instability is expected during any drilling operation. Wellbore instability is usually caused by a combination of factors which may be broadly classified as being either controllable or uncontrollable (natural) in origin. Pašić *et al.* (2007) compiled Table 9.1 that shows various factors that contribute to the origin of wellbore instability.

#### 9.1.1.1 Uncontrollable Factors

It is important to know about uncontrollable factors in order to design a drilling operation that minimizes the possibility of wellbore instability.

**Table 9.1** Causes of wellbore instability.

Uncontrollable factors	Controllable factors
1. Naturally fractured and/or faulted formations	1. Bottomhole pressure
2. Tectonically stressed formations	2. Well inclination and azimuth
3. High in-situ stresses	3. Transient pore pressures
4. Mobile formations	4. Physico-chemical rock-fluid interaction
5. Unconsolidated formations	5. Drilling string vibrations
6. Naturally overpressurized shale collapse	6. Erosion
7. Induced overpressurized shale collapse	7. Temperature

Borehole instability is significant in naturally fractured and/or faulted formations. A natural fracture system in the rock can often be found near faults, although the direction of principal axis of the Rose diagram is perpendicular to the direction of the fault (Islam, 2014). As the drilling operation continues, rock bodies near faults can be broken into large or small pieces. If they are loose they can fall into the wellbore and jam the string in the hole (Goud, 2017). Even if the pieces are bonded together, impacts from the BHA due to drill string vibrations can cause the formation to fall into the wellbore, thus creating stuckpipe problems. As Goud (2017) points out, this type of stuckpipe problems are common in drilling through faulted or highly fractured limestone formations. Often, this problem can be alleviated by choosing an alternative RPM or changing the BHA configuration to minimize high-level shocks.

Figure 9.1 shows possible problems because of drilling a naturally fractured or faulted system. As shown in this figure, whenever a fractured formation is traversed, the borehole wall is susceptible to shed debris that can enlarge the wellbore and at the same risk jamming the drill collar. This chain of problems become more severe if weak bedding planes intersect a wellbore at unfavorable angles. Such fractures in shales may provide a pathway for mud or fluid invasion that can lead to time-dependent strength degradation, softening and ultimately to hole collapse. The relationship between hole size and the fracture spacing will be important in such formations.

Wellbore instability can occur when formations, under high level of natural stress, are drilled and there is a significant difference between the near wellbore stress and the restraining pressure provided by the drilling fluid

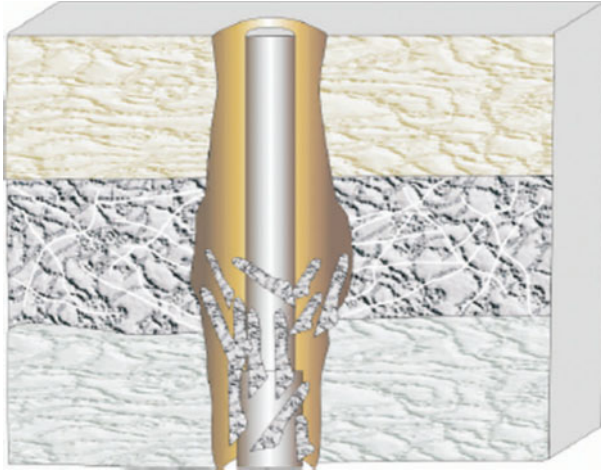

**Figure 9.1** Drilling through naturally fractured or faulted formations (from Pašić *et al.*, 2007).

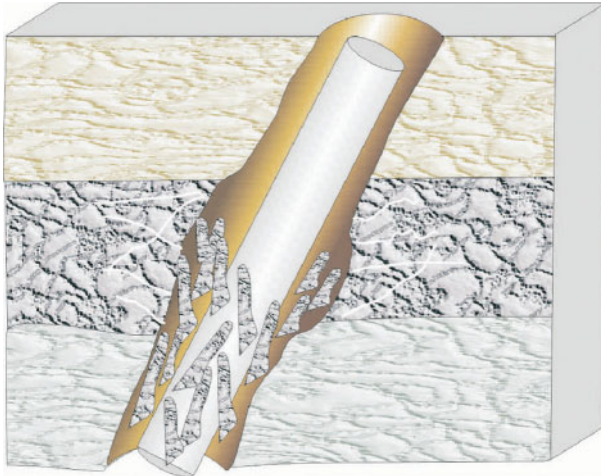

**Figure 9.2** Drilling through tectonically stressed formations (from Pašić *et al.*, 2007).

density. Tectonic stresses build up in areas where rock is being compressed or stretched due to movement of the earth's crust. Even though this is a very slow process, it is still a dynamic process and the rock in these areas is in a state of being buckled by the pressure of the moving tectonic plates. When a hole is drilled in an area of high tectonic stresses, the rock around the wellbore will collapse into the wellbore and produce splintery cavings similar to those produced by over-pressured shale (Figure 9.2). Connecting

cavings to borehole instability and its mechanism entails correct description coupled with proper interpretation of the geology, geomechanics, and drilling system and process (Kumar *et al.*, 2012). In the tectonic stress case the hydrostatic pressure required to stabilize the wellbore may be much higher than the fracture pressure of the other exposed formations.

Planning to case off these formations as quickly as possible and maintaining adequate drilling fluid weight can help to stabilize these formations. However, there may be scenarios for which (e.g., thick section) casing off as a priority cannot be accomplished.

Another scenario, for which wellbore instability would be a natural issue is where high in-situ stresses prevail. Examples of such scenarios are: salt formations, including salt domes, near faults, or in the inner limbs of a folds. Similarly, gypsum and anhydrite and potash salts (such as a carnallite and polyhalite). Evaporites, particularly rock salt, will flow under pressure and may be found in salt domes pushed, and still moving from their original position, upward into overlying strata, thus creating an inherent instability. The susceptibility of these rocks to creep gives problems during drilling of a hole. Finally, stress concentrations may also occur in particularly stiff rocks such as quartzose sandstones or conglomerates. Only a few case histories have been described in the literature for drilling problems caused by local stress concentrations, mainly because of the difficulty in measuring or estimating such in-situ stresses.

Another category is the mobile formation. Mobile formation is caused by overburdened pressure that squeezes shale and/or salt into a wellbore. Mobile formations behave in a plastic manner, deforming under pressure. The squeezed formations reduce wellbore diameter; therefore, the drill string/BHA gets stuck inside the wellbore. The deformation results in a decrease in the wellbore size, causing problems of running BHAs, logging tools and casing (Figure 9.3).

It could happen at anytime as drilling, tripping in and tripping out depending on how fast plastic formations are moved (Abduljabbar *et al.*, 2018). Over pull, down weight and torque are suddenly increased. Most of the time, the BHA gets stuck at the plastic zones because BHA contains the largest diameter component. A deformation occurs because the mud weight is not sufficient to prevent the formation squeezing into the wellbore. Consequently, the problem can be averted by increasing mud weight, which itself has the risk of exceeding fracture pressure. Also, for drilling through salt formations, higher salinity mud can help stabilize these formations.

In general, an unconsolidated formation is also vulnerable to wellbore stability. This genre of instability mechanism is normally associated with

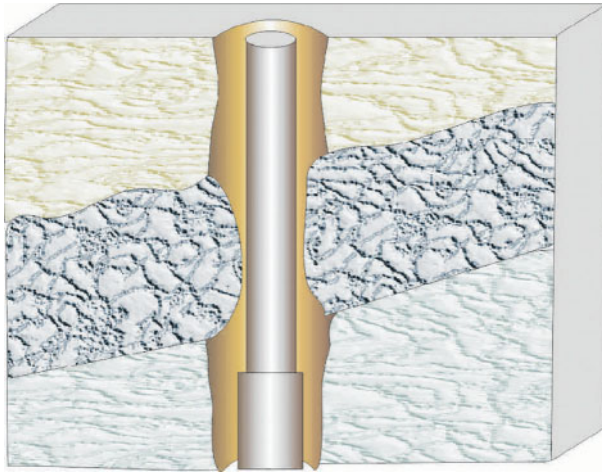

**Figure 9.3** Drilling through a mobile formation (from Pašić *et al.*, 2007).

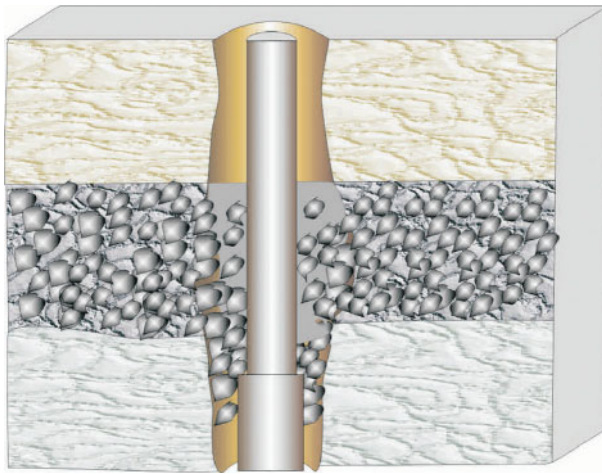

**Figure 9.4** Instability in an unconsolidated formation.

shallow formation. Unconsolidated formations have very little cohesive forces within the grains that form the formation. This leads to excessive amounts of rock detaching from the wellbore wall, falling into the well and effectively clogging it. The collapse of formations is caused by removing the supporting rock as the well is drilled (Figure 9.4). It happens in a wellbore when little or no filter cake is present. The unbonded formation (sand, gravel, etc.) cannot be supported by hydrostatic overbalance as the fluid

simply flows into the formations. Sand or gravel then falls into the hole and packs off the drillstring. The effect can be a gradual increase in drag over several meters, or can be sudden. If this occurs while the drilling apparatus is in the wellbore, then the apparatus may become stuck. If this occurs while the apparatus is extracted from the wellbore (e.g., while changing the bit), then it might become necessary to redrill or ream all or portions of the well falls into the wellbore because it is loosely packed with little or no bonding between particles, pebbles or boulders. An adequate filter cake is required to help stabilize these formations. As such the composition of mud plays a role in preventing this type of borehole instability.

It is estimated that 90% of wellbore instability-related problems are associated with shale formations (Mody and Fisk, Jr., 1996). Some examples of the types of problems encountered in shales are illustrated in Figure 9.5. Of particular importance in this work is the behavior of elastic-plastic and elastic-brittle-plastic shales.

These rocks possess a number of characteristic physical properties which lead to unique drilling problems. Most important of these properties are:

1. **Mechanical weakness:** The stresses acting around a wellbore are usually quite large. Consequently, a weak rock is likely to be stressed beyond its peak strength and fail in some manner.
2. **Low permeability:** Because the volume of drilling mud flowing into low-permeability formations is small, no filter cake builds up to prevent interaction of the mud with the

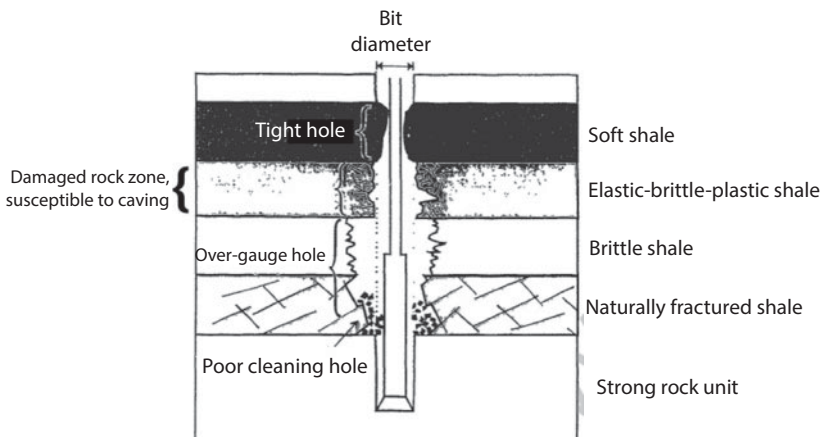

**Figure 9.5** Examples of borehole instability during drilling of a shaly formation.



formation. Hence, when an overbalance pressure exists, the relatively high fluid pressures in the wellbore will diffuse into (i.e., penetrate) the formation.

3. **High clay content:** Shales often consist predominantly of fine clay particles. Clays, particularly montmorillonite group varieties, are very sensitive to changes in water content and chemistry; hence, shales often swell and/or weaken on contact with water-based drilling muds.

Naturally overpressured shales are most commonly caused by geological phenomena such as undercompaction, naturally removed overburden and uplift (Figure 9.6). Using insufficient mud weight in these formations



Figure 9.6 Drilling through a naturally overpressured shale.

will cause the hole to become unstable and collapse. The short time hole exposure and an adequate drilling fluid weight can help to stabilize these formations.

Induced over-pressured shale collapse occurs when the shale assumes the hydrostatic pressure of the wellbore fluids after a number of days exposure to that pressure. If the pressure conditions are not changed, the shale collapses in a similar manner to naturally overpressured shale (Figure 9.7). This mechanism normally occurs in water-based drilling fluids, after a reduction in drilling fluid weight or after a long exposure time during which the drilling fluid remained stagnant.



Figure 9.7 Drilling through induced over-pressured shale.

### 9.1.1.2 Controllable Factors

Controllable factors relate to engineering parameters that can affect chemical and/or mechanical stability of a wellbore. Because drilling fluids range from water to oil to complex chemical systems with properties designed for specific site conditions to aid the drilling process, chemical compatibility looms large during a drilling operation. On the other hand, drilling fluids perform many mechanical functions, such as carrying cuttings out of the hole, cleaning the bit, cooling and lubricating the bit, providing buoyancy to the drillstring, controlling formation fluid pressures, preventing formation damage, and providing borehole support, thereby making the wellbore dependent on mechanical stability (Hossain and Al-Majed, 2015).

#### 9.1.1.2.1 Mechanical Factors

The most important factor that affects the wellbore stability is the bottomhole pressure, which is a direct function of the mud density. Figure 9.8 shows the location of the safe drilling window. It is known that there is a lower limit of mud weight below which compressive failure occurs, and an upper limit beyond which tensile failure occurs. The range between the lower and the upper limit is defined as the mud weight window. The derived equations from the Mohr–Coulomb and the Mogi–Coulomb criteria accompanying rock mechanics and stress properties can be used to determine the optimum mud weight window (Hossain and Al-Majed, 2015). The supporting pressure offered by the static or dynamic fluid pressure during either drilling, stimulating, working over or producing of a well, will determine the stress concentration present in the near wellbore vicinity. Because rock failure is dependent on the effective stress, the consequence for stability is highly dependent on whether and how rapidly fluid pressure penetrates the wellbore wall. That is not to say, however, that high mud densities or bottomhole pressures are always optimal for avoiding instability in a given well. In the absence of an efficient filter cake, such as in fractured formations, a rise in a bottomhole pressure may be detrimental to stability and can compromise other criteria, e.g., formation damage, differential sticking risk, mud properties, or hydraulics.

Inclination and azimuthal orientation of a well with respect to the principal in-situ stresses are important factors that can cause risks of collapse during a drilling process. Figure 9.9 shows how inclination defines the region of hole stability. The well trajectory can be optimized based on the analysis of the effects of well inclination and azimuth on mud weight window. Figure 9.9 illustrates the safe mud window of vertical and horizontal wells, for which the mud weight window expands gradually with increasing drilling depth. Figure 9.10 shows the safe mud weight window for wellbore

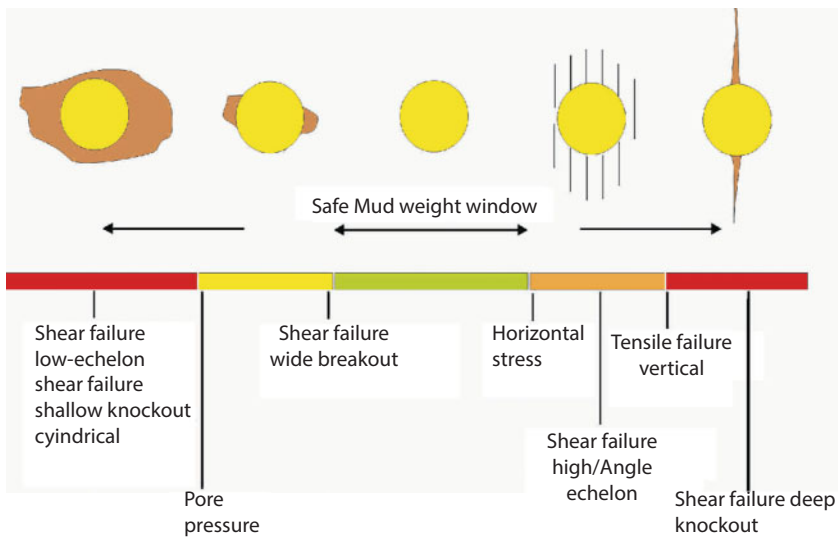

Figure 9.8 Effect of mud weight on the stress in wellbore wall.

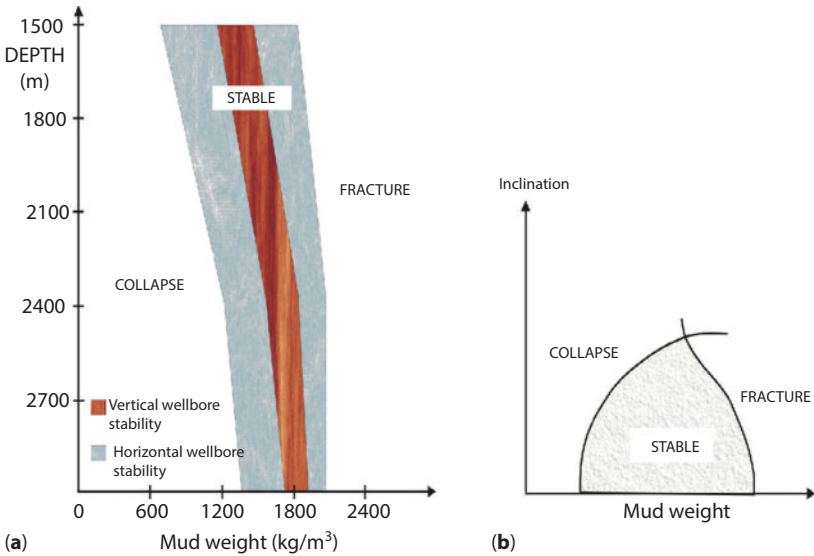
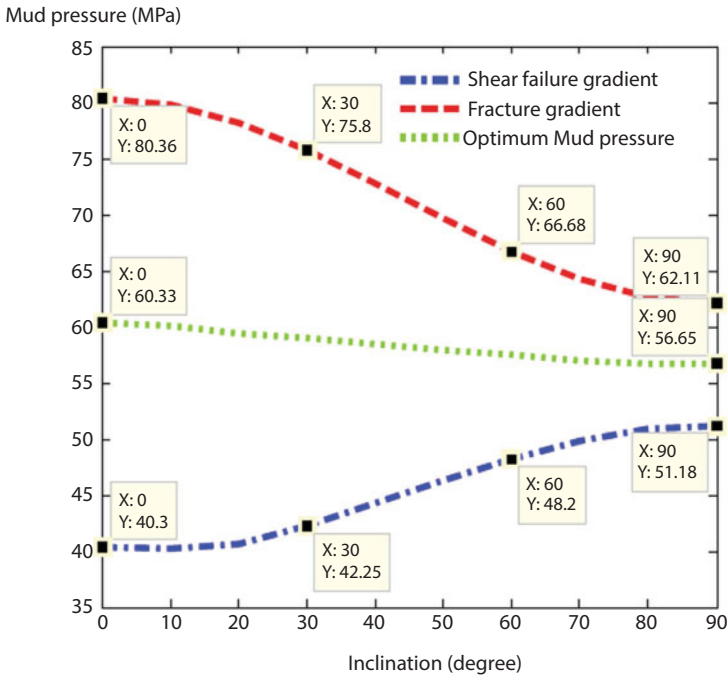

Figure 9.9 Effect of the well depth (a) and the hole inclination (b) on wellbore stability.

stability in different inclinations obtained by the Mohr–Coulomb and the Mogi–Coulomb criteria. Figures 9.9 and 9.10 show that the mud weight window is narrowed gradually with the increase in wellbore inclination that represents a vertical well requires the lowest mud weight to prevent



**Figure 9.10** Mud weight window versus wellbore inclination (From Aslannezhad *et al.*, 2016).

breakout and, conversely, horizontal wells require the highest mud weight to maintain wellbore stability. As illustrated in Figure 9.10, the fracture and shear failure pressure predicted by the Mohr–Coulomb criterion at the inclination of  $0^\circ$  are about 80.36 and 40.3, and at the inclination of  $90^\circ$  they are about 62.11 and 51.18 MPa, respectively, and the optimum mud pressure will be obtained within the range of the mud weight window.

Physical/chemical fluid-rock interactions, along with compatibility issues, form the next set of factors that affect wellbore stability. These include hydration, osmotic pressures, swelling, rock softening and strength changes, and dispersion. The significance of these effects depends on a complex interaction of many factors including the nature of the formation (e.g., mineralogy, stiffness, strength, pore water composition, stress history, temperature), the presence of a filter cake or permeability barrier presence, the properties and chemical composition of the wellbore fluid, and the extent of any damage near the wellbore. Various physico-chemical phenomena impact the wellbore stability. They are (Aslannezhad *et al.*, 2016): (i) interaction between shale and drilling fluid, (ii) mechanical/

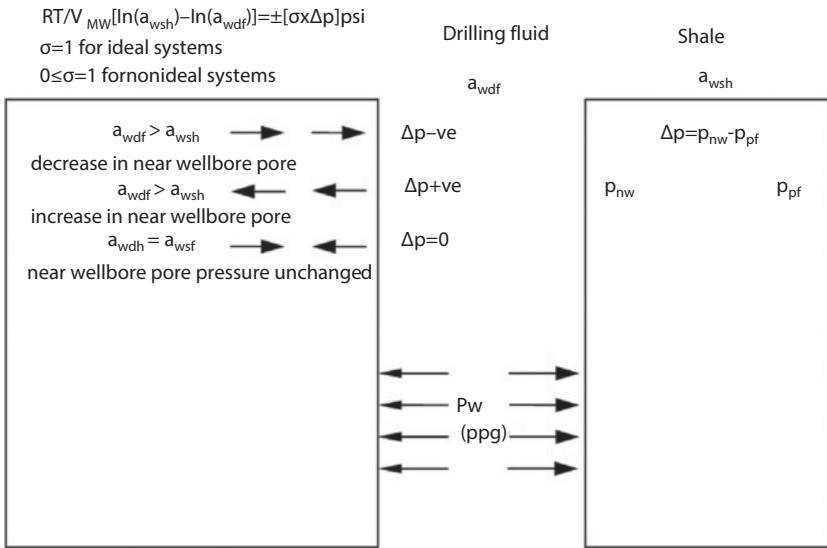

Figure 9.11 Conception model of Mody and Hale.

chemical coupling of the wellbore, (iii) depression of lubricants that are main shale inhibitors.

Mody and Hale (1993) proposed a conceptual chemical potential, bore-hole stability model based on the interaction mechanism of drilling fluid and shale (Figure 9.11). According to this model, this mechanism can generally be divided into four parts: (i) the water activity affecting the stability of shale wellbore, (ii) the membrane efficiency affecting water entrance, (iii) the clay content influencing rock properties, and (iv) the drilling fluid influencing rock strength.

The difference between the water activity of drilling fluid and that of formation fluid is an important factor in controlling shale activity. On the one hand, the highly active (or undersaturated, such as low-salt) water in the drilling fluid may flow into the shale formation. Meanwhile, increasing the number of pores in the shale formation and reducing effective stress inflates the shale. This inflation of the formation shale can lead to bore-hole instability. On the other hand, highly salty drilling fluid may cause the water in the shale pores to flow into the wellbore, thus reducing the pore pressure in the shale significantly. This leads to rapid crack formation in the shale that can reduce wellbore stability.

An effective approach to improving the stability of shale wellbore is by resisting the wellbore avalanche through enhancing drilling fluid density. For instance, the angle of the wellbore avalanche drops from  $100^\circ$  to  $60^\circ$

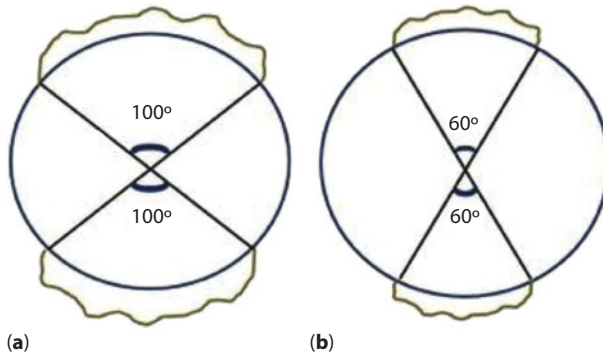

**Figure 9.12** Angles of the wellbore avalanche: (a) 100° wellbore avalanche (More than half of the wall is damaged. The wellbore is instable, although density is unchanged); (b) 60° wellbore avalanche (Less than half of the wall is damaged. The wellbore is stable, but density increases by 0.5 ppg). (From Zhang *et al.*, 2015).

(Figure 9.12) as drilling fluid density increases by 0.5 ppg (Zhang *et al.*, 2015). The increase in drilling fluid should not be increased to too high a value that would cause its loss or fracturing of the formation. Thus, drilling fluid density must be optimized.

Drillstring vibrations can enlarge holes in some circumstances. As such, they are considered to be important operating factors that can alter wellbore stability. The applied heavy and complex dynamic loadings on the drillstring that are caused by the rotation of the rotary top drive in the surface can produce different states of stresses with a turbulent movement in the downhole and consequently causing excessive vibrations and potentially premature failure. The application of drilling aid methods such as air drilling may also exacerbate the drillstring vibration due to the damping effect of the drilling fluid. There are three forms of drillstring vibrations: axial, torsional, and lateral vibrations. Axial vibration is occurred when the drillstring moves along its axis of rotation; torsional vibration is occurred when an irregular rotation of the drillstring rotated from the surface at a constant speed, and lateral vibration is occurred when the drillstring moves laterally to its axis of rotation. Optimal bottomhole assembly (BHA) design with respect to the hole geometry, inclination, and formations to be drilled can sometimes eliminate this potential contribution to wellbore collapse. It is also believed that hole erosion may be caused due to a too high annular circulating velocity. This may be most significant in a yielded formation, a naturally fractured formation, or an unconsolidated or soft, dispersive sediment. The problem may be difficult to diagnose and fix in an inclined or horizontal well where high circulating rates are often desirable to ensure adequate hole cleaning.

Several researchers identified the effects of varying drillstring velocities of translation and rotation to maximize the efficiency of drilling process on nonlinear stochastic dynamics i.e., bit-bounce, stick-slip, and transverse impacts. For instance, Kreuzer and Steidl (2012) studied the effect of changing the direction of dynamics traveling waves; in the direction of the top drive and in the direction of the drill bit on the torsional vibrations (or stick-slip vibrations) in the drillstring. It was revealed that the stick-slip vibrations are detrimental to the drilling process where they slow down the rate of penetration and then possibly lead to the drilling failure. The effects of lateral vibrations on bottomhole assembly (BHA) during back reaming operations (or during the operation of pulling out the drillstring) were evaluated by Agostini and Nicoletti (2014), who showed that the occurrence of abnormal lateral vibrations during back reaming can effectively cause BHA electronic equipment failure, falling rocks into the well, and drillstring blockage.

The drillstring vibrations in relation to the effective length of the string when it rests on the borehole wall and the exact form of the beam curvature were analyzed by Hakimi and Moradi (2010) using the differential quadrature method (DQM). The numerical results showed that the axial and torsional natural frequencies are affected by the length of string and the beam curvature and consequently detrimental to the efficiency and accuracy of the drilling process.

Drilling fluid temperatures, and to some extent, bottomhole producing temperatures can give rise to thermal concentration or expansion stresses which may be detrimental to wellbore stability. The reduced mud temperature causes a reduction in the near-wellbore stress concentration, thus preventing the stresses in the rock from reaching their limiting strength (McLellan, 1994a).

#### 9.1.1.2.2 Chemical Factors

Because the composition of the drilling fluid is never the same as that of the formation fluid, any drilling fluid will create compatibility concerns, triggering chemical imbalance. In presence of complex formations, such as shale, chemical interaction between rock and fluid itself can cause instability. Each system must be considered carefully in order to custom design a process that minimizes interactions between fluids and the rock.

One peculiar aspect of chemical effects is the mechanical properties of the rock can be altered seriously after contacting with drilling fluid. Existing forms of water in the rock mainly include water vapor, solid water, bound water, adsorption water (film water), capillary water, and gravity water (free water). Owing to the direct contact with drilling fluid around the wellbore, the free water of drilling fluid diffuses into the rock under



physical and chemical driving force. During the drilling process, the absorption water will increase, and the diffusion layer of rock particle will thicken, which will cause volume increase of formation shale and produce swelling stress. In order to calculate the swelling stress caused by hydration, the relation between water absorption and the swelling must be researched first through experiments. This has to be done for each field and the results should dictate the nature of drilling fluids.

In considering the chemical effects, one must recall that shaley formations are most vulnerable to chemical alterations. For instance, the low permeability of shale makes creating mud cake at the wellbore wall difficult, causing water and pressure penetrating within the shale matrix and pores and increasing the pore pressure, thus triggering mechanical instability, the immediate outcome of an increase in pore pressure. This increase in pore pressure can lead to alteration of the stress map within the wellbore. If the hydrostatic pressure of mud is not adequate to support the formation fluid pressure, shale yielding can take place in the form of sloughing into the wellbore, thus causing wellbore instability. Depending on the compatibility of the chemical composition of the formation fluid and the drilling fluid, the shale formation creates an additional pressure called "swelling pressure" that needs to also be included in the mud pressure calculations and drilling fluid design. It is well known that the shale strength and the pore pressure near the bore-hole are affected by fluid/shale interaction.

These interactions result in the production of swelling stress. At the same time, swelling alleviates the mechanical strength of the wellbore wall rock, leading to wellbore instability. Various results of these interactions can be summarized as:

1. Activity imbalance causes fluid flow into/or out of shale
2. Different drilling fluids and additives affect the amount of fluid flow in or out of shale
3. Differential pressure or overbalance causes fluid flow into shale
4. Fluid flow into shale results in swelling pressure
5. The moisture content affects shale strength.

Dokhani *et al.* (2015) demonstrated that the pore pressure response of various shale types directly relates to the sorption tendency of the shale matrix, regardless of the chemical potential difference between the shale and drilling fluid. The time evolution of moisture content, which is correlated with the uniaxial compressive strength of the rock, significantly affects the wellbore stability analysis. This in turn would dictate the nature of safe

mud weight under various moisture transport scenarios. They further showed that the influence of moisture content on the mud weight window is manifested in both conventional triaxial and polyaxial failure criteria.

The instability and shale/fluid interaction mechanisms, coming into play as drilling fluid contacts the shale formation, can be summarized as follows (Lal, 1999):

1. Mechanical stress changes as the drilling fluid of certain density replaces shale in the hole. A mechanical stability problem caused by various factors is fairly well understood, and stability analysis tools are available.
2. Fractured shale - Fluid penetration into fissures and fractures and weak bedding planes.
3. Capillary pressure,  $P_c$ , as drilling fluid contacts native pore fluid at narrow pore throat interface.
4. Osmosis (and ionic diffusion) occurring between drilling fluid and shale native pore fluid (with different water activities/ ion concentrations) across a semi-permeable membrane (with certain membrane efficiency) due to osmotic pressure (or chemical potential).
5. Hydraulic (Advection),  $p_h$ , causing fluid transport under net hydraulic pressure gradient because of the hydraulic gradient.
6. Swelling/Hydration pressure,  $P_s$ , caused by interaction of moisture with clay-size charged particles.
7. Pressure diffusion and pressure changes near the wellbore (with time) as drilling fluid compresses the pore fluid and diffuses a pressure front into the formation.
8. Fluid penetration in fractured shale and weak bedding planes can play a dominant role in shale instability, as large block of fractured shale fall into the hole.

Increasing the capillary pressure for water-wet shale is possibly the most useful way to prevent invasion of drilling fluid into shale. Such increase in capillary pressure can be made through the use of oil-based and synthetic mud, thus using esters, poly-alpha-olefin and other organic low-polar fluids for drilling shale. The capillary pressure is given by

$$p_c = 2\gamma \frac{\cos \theta}{r} \quad (9.1)$$

where,  $\gamma$  is the interfacial tension,  $\theta$  is contact angle between the drilling fluid and native pore fluid interface, and  $r$  is the characteristic pore radius of the formation. Because the characteristic pore radius is very small for shaley formations whereas the interfacial tension is high, the capillary pressure developed at oil/pore-water contact is large. Such large value of  $p_c$  prevents the entry of the oil into shale since the hydraulic overbalance pressure,  $p_h (= p_w - p_o)$ , is lower than the capillary threshold pressure,  $p_c$ . In such a case, dispersive forces are minimal. However, osmosis and ionic diffusion phenomena can still occur under favorable conditions. Capillary pressure thus modifies  $p_h$  and the net hydraulic driving pressure  $p_h$  is given as follows:

$$p_h = p_h - p_c, 0 < p_c < p_h \quad (9.2a)$$

$$p_h = 0, p_c > p_h \quad (9.2b)$$

As stated earlier, capillary pressures for low permeability water-wet shales can be very high (about 15 MPa for average pore throat radius of 10 nm). This is one of the key factors in successful use of oil base muds or synthetic muds using esters, poly-alpha-olefin and other organic low-polar fluids. Osmotically induced hydraulic pressure or differential chemical potential,  $P_M$ , developed across a semi-permeable membrane is given by (Lal, 1999):

$$P_M = -\eta P_\pi = -\eta \left( \frac{RT}{V} \right) \ln \frac{A_{sh}}{A_m} \quad (9.3)$$

where,  $\eta$  is membrane efficiency,  $P_\pi$  is the theoretical maximum osmotic pressure for ideal membrane ( $\eta = 1$ ),  $R$  is the gas constant,  $T$  is the absolute temperature,  $V$  is the molar volume of liquid, and  $A_m, A_{sh}$  are the water activities of mud and shale pore fluid, respectively. There have been suggestions of various phenomenological expressions for defining the membrane efficiency in terms of parameters that are difficult to measure. Two such expressions are:

$$\eta = 1 - \frac{(a - r_s)^2}{(a - r_w)^2} \quad (9.4a)$$

$$\eta = 1 - \frac{v_s}{v_w} \quad (9.4b)$$

where, 'a' is pore radius,  $r_s$  is solute radius,  $r_w$  is water molecule radius, and  $v_s$  and  $v_w$  are the velocities of solute and water, respectively.

From non-equilibrium thermodynamics principles, assuming slow process near equilibrium and single nonelectrolyte solute, the linear relationships between the pressure and flow can be written as:

$$J_v \Delta x = L_p P_h - L_p \eta P_\pi \quad (9.5)$$

$$J_s \Delta x = C_s (1 - \eta) J_v + \omega P_\pi \quad (9.6)$$

$$J_v = J_w V_w - J_s V_s \quad (9.7)$$

In Eqn. (9.5), it is recognized that the fluid flux  $J_v$  into shale is the superposition of fluxes due to hydraulic pressure gradient  $P_h$  (advection) and due to osmotically induced pressure,  $P_M (= \eta P_\pi)$ , related through the hydraulic permeability coefficient,  $L_p$ .

The coefficient  $L_p$  is related to the shale permeability,  $k$ , and filtrate viscosity,  $\mu$ , as  $L_p = k/m$ . Eq. (9.6) describes the net salt flux  $J_s$  into the shale. Eq. 9.7 expresses the mass balance in terms of the water and salt flux and partial molar volumes of these components. Note that for perfect membrane,  $\eta = 1$ , since only water can flow across the membrane,  $J_s = 0$  and thus  $\omega = 0$ . Hydraulic (Advection),  $p_h$ , is implicitly included in Eq. 9.5. If the test fluid is the same as shale pore fluid (which implies equal activity and  $P_\pi = 0$ , implying no osmosis), Eq. 9.5 is reduced to Darcy's equation, in which volumetric flow is expressed as:

$$J_v \Delta x = L_p p_h \quad (9.8)$$

where  $L_p = k/m$ ;  $k$  denotes shale permeability and  $\mu$  denotes viscosity. Lal (1999) points out a Gas Research Institute (GRI) study that conducted a series of experimental tests to study the effect of osmotic and hydraulic pressures to come up with the following conclusions:

1. An increase in hydraulic potential can increase the amount of transport of water into shales and reduce rock strength (with exposure time). Increasing the mud weight may thus worsen a stability problem (over time) rather than curing it.
2. In hydrocarbon-based fluids, water transport into shales may be controlled through the activity of the internal phase relative to the shale.

3. Water-based fluids require a much lower activity than the shale to control water transport. Even then the effective strength may be reduced.
4. Swelling pressure and swelling behavior of shales is directly related to the type and amount of clay minerals in a given shale. Two types of swelling observed in clays are: a) Innercrystalline swelling (IS) – caused by hydration of the exchangeable cations of the dry clay; b) Osmotic swelling (OS) – caused by large difference in the ionic concentrations close to the clay surfaces and in the pore water.

Swelling experiments indicate that the swelling follows a diffusion type of law, and the cumulative water flux into the shale,  $Q$ , time  $t$ , sorptivity  $S$ , the change in equilibrium void ratio (liquid to solid volume ratio)  $\Delta e$ , and diffusivity,  $D$ , are related as follows:

$$Q = S.t^{0.5} \quad (9.9a)$$

$$S = \Delta e.(2D)^{0.5} \quad (9.9b)$$

If a drilling fluid cannot penetrate shale at all (e.g., perfect oil base mud for a given shale), the pore pressure near the wellbore wall is the virgin pore pressure  $p_o$  (ignoring the effect of stress changes) at the time drilling fluid comes in contact with shale ( $t = 0$ ) and remains the same for  $t > 0$ . However, when the mud is such that it interacts with shale, the drilling fluid at wellbore pressure  $P_w$  will diffuse through shale. The pressure near the wall in the pores will increase from  $p_o$  with time. How fast this pore pressure in the vicinity of the borehole increases depends upon the permeability of shale, its elastic properties and other boundary conditions. In general, the lower the permeability, the more time it takes for pressure to increase and tend to equalize with  $P_w$ , thus losing pressure support for the formation. Depending on permeability, it may take anywhere from a few hours to a number of days before the pressure near the wellbore approaches the wellbore pressure, losing pressure support, reducing effective stresses and bringing the rock to unstable situation. This could be an explanation for the delayed failure of exposed shale sections, often experienced in the field.

Each of the chemical factors is affected by the temperature. Therefore, it is important to consider temperature for all chemical tests conducted. For the field applications, circulation of cold drilling fluid into the wellbore can cause stress alteration due to rock temperature change. For hard rocks, this may cause the creation of temperature induced fractures. During drilling,

such fractures can create additional constraints on fluid loss and related factors. Aadnoy and Looyeh (2011) calculated the thermally induced stress as follows:

$$\sigma_T = \frac{\sigma_m E(T - T_o)}{1 - \nu} \quad (9.10)$$

where  $\nu$  is the Poisson's ratio,  $E$  is Young's modulus,  $\sigma_m$  is a volumetric thermal expansion coefficient of rock matrix ( $^{\circ}\text{K}^{-1}$ ),  $T$  is the circulation temperature ( $^{\circ}\text{K}$ ), and  $T_o$  is virgin rock temperature ( $^{\circ}\text{K}$ ).

### 9.1.2 Indicators of Wellbore Instability

A list of the indicators of wellbore instability which are primarily caused by wellbore collapse or convergence during the drilling, completion or production of a well is shown in Table 9.2. They are classified in two groups: direct and indirect causes. Direct symptoms of instability include observations of overgauge or undergauge hole, as readily observed from caliper logs (Mohiuddin *et al.*, 2001). Caving from the wellbore wall, circulated to surface, and hole fill after tripping confirm that spalling processes are occurring in the wellbore. Large volumes of cuttings and/or cavings, in excess of the volume of rock, which would have been excavated in a gauge hole,

**Table 9.2** Indicators of wellbore instability.

Direct indicators	Indirect indicators
Oversize hole	High torque and drag (friction)
Undergauge hole	Hanging up of drillstring, casing, or coiled tubing
Excessive volume of cuttings	Increased circulating pressures
Excessive volume of cavings	Stuck pipe
Cavings at surface	Excessive drillstring vibrations
Hole fill after tripping	Drillstring failure
Excess cement volume required	Deviation control problems
–	Inability to run logs
–	Poor logging response
–	Annular gas leakage due to poor cement job
–	Keyhole seating
–	Excessive doglegs

similarly attest to hole enlargement. Provided the fracture gradient was not exceeded and vuggy or naturally fractured formations were not encountered, a requirement for a cement volume in excess of the calculated drilled hole volume is also a direct indication that enlargement has occurred.

9.1.2.1 *Diagnosis of Wellbore Instability*

Figure 9.13 shows various steps involved in diagnosis of the four most important mechanisms behind wellbore instability. These mechanisms are: (i) breakouts, (ii) closely spaced natural fractures and weak planes, (iii) drilling induced fractures, and (iv) chemical activity. The first three of these mechanisms are mechanical whereas the last one is chemical in origin.

9.1.2.2 *Preventative Measures*

A mechanical stability problem can be prevented by restoring the stress-strength balance through adjustment of mud weight and effective

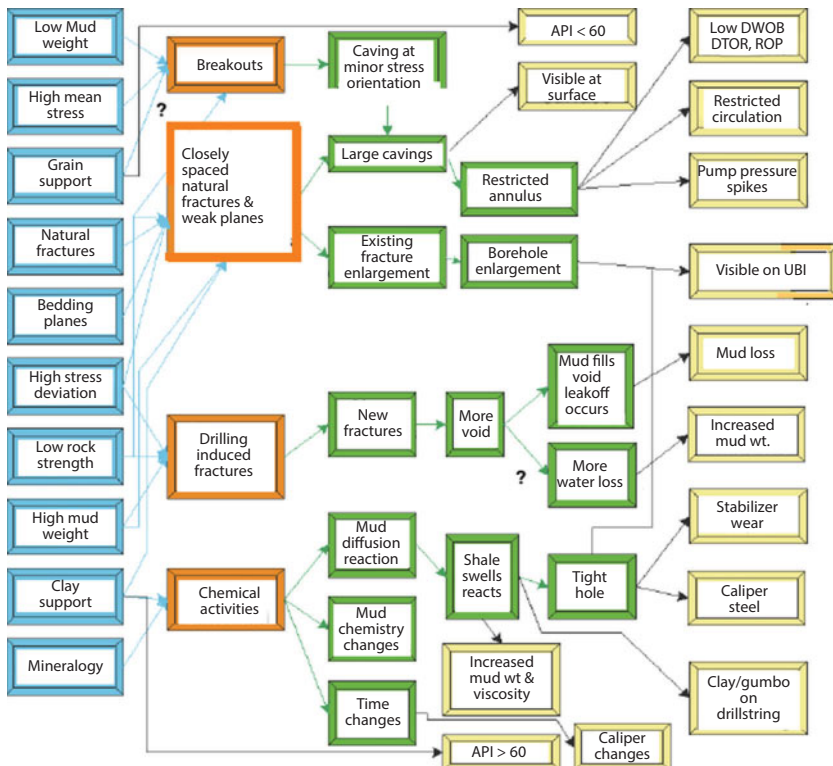

Figure 9.13 Diagnosing the four most common wellbore instability mechanisms.

circulation density (ECD) through drilling/tripping practices, and trajectory control. Various previous chapters have detailed discussions on preventative measures to be taken for mechanical instability problems and as such would not be repeated here.

The chemical stability problem, on the other hand, is time dependent unlike mechanical instability, which occurs as soon as we drill new formations. Chemical instability can be prevented through selection of proper drilling fluid, suitable mud additives to minimize/delay the fluid/shale interaction, and by reducing shale exposure time. Selection of proper mud with suitable additives can even generate fluid flow from shale into the wellbore, reducing near wellbore pore pressure and preventing shale strength reduction.

As damage control, certain measures can be taken to limit the dispersion of cuttings or spallings by binding the clay particles together, if shale failure or erosion is initiated. Polymers that can reduce shale disintegration must adsorb onto clay platelet surface and have high enough energy to resist mechanical or hydraulic forces pulling them apart. PHPA and strongly adsorbing cationic polymers and components like polyglycerol can limit the dispersion of shale cuttings or spallings in the well. To achieve similar results within the shale formation, polymer must be able to diffuse into the bulk shale, requiring short flexible chains.

Preventative measures against chemically induced instability is mainly countered with drilling fluids that have specific properties against chemical instabilities. Preventive measures include use of effective sealing agents for fractures, e.g., graded  $\text{CaCO}_3$ , high viscosity for low shear rates, and lower ECD.

A series of chemical additives have been suggested in order to minimize swelling with drilling fluids. Bol (1986) carried out extensive tests using various salt additives and polymers. It is shown that the volumetric swelling of the shale will not be considerable at confining pressures above 100 bar. The author pointed out that polymers may affect the rate of hydration, hence reducing cuttings disintegration. Reid *et al.* (1992) stated that the adsorption of Partially hydrolyzed polyacrylamide (PHPA) on mineral surfaces provides a coating that enhances mechanical integrity of shale against the mud filtrate. They added 5% to 10% polyglycerol to a KCl/PHPA solution and the solution was tested against off-set wells. The authors reported a better performance of this system with respect to the basic system (KCl/PHPA). Although they proposed several explanations for the inhibition properties of the new system, the overall effect is a combination of lowering water activity of the drilling fluid as well as absorption of chemicals onto clay surfaces, which retards the shale-fluid interactions. Cook *et al.* (1993) employed Computer Tomography scanning with a modified



pressure vessel to study shale-drilling fluid interactions under downhole stress conditions. The CT scanning technique enabled them to detect the propagation of swelling and cracking inside shale samples. It was found that a drilling fluid with a high concentration of KCl (i.e., a lower water activity) hinders the growth of the swollen zone. Clark and Benaissa (1993) investigated the chelation of an aluminum salt with an organic acid. Their investigation led to a new generation of aluminum complexes for water-based drilling fluids. The addition of aluminum salt reduced the hydration of Pierre shale and improved the shale hardness. However, the associated cost of acid reduced the economic justification of the project. The results of the field test showed a reduction in washout and an improvement of the solid removal efficiency. Van Oort *et al.* (1994a) recommended adding chemical plugging agents to the drilling fluid or increasing the mud filtrate viscosity (i.e., adding low molecular weight viscosifiers) to reduce the fluid invasion in shale. The authors also stated that using chemical additives (which create an osmotic backflow) to compensate the hydraulic invasion could be a good approach for intact and low permeable shales. Although KCl is recognized as an excellent clay inhibitor, it is shown that the viscosity of the solution does not change, even at saturation levels (van Oort, 1994b).

Carminati *et al.* (2000) analyzed the inhibitive performance of different chemical additives using the Pressure Transmission Technique (PTT), which is the same as PPT. The permeability of shale samples was reported to be in the range of 50 to 100 nD. For the silicate mud, the results indicate that pore blocking improves the stability of shale. Hardness tests indicate that both cationic polymers and silicates increase the shale strength. It is shown that glycols are only effective when the potassium ion is included in the solution. It is stated that the cationic polymers can bind the negatively charged surfaces of the clay together and hence reduce the shale hydration. Aston *et al.* (2007) modified the method of wellbore strengthening to be applicable in drilling shale formations. The name "Stress Caging" was already known as a means of increasing the hoop stress around the borehole using induced fractures to increase compressive stresses. Using the bridging material, one can maintain fractures open and induce the stress cage effect or strengthen the wellbore. Their approach was to transport the bridging particulates in a settable media to solidify the fracture. They also modified the adherence properties of the material to the shale. However, application of this solution has only been made for oil-based mud systems, where the field implementation of this new treatment technique indicates a need to modify the procedure of pressure squeezing. The results of formation integrity tests signify that the extension of this treatment to water-based muds should be further investigated. Shale stabilization often requires over

3% of chloride concentration while the governmental regulations prohibit surface disposal of salt brines containing greater than 0.3% chloride. This issue stimulated many researchers to seek other alternatives to replace the conventional chemical additives (Cai *et al.*, 2011). The study of Cai *et al.* (2011) focused on the implementation of non-modified nanoparticles to decrease water intake of shale formations. It should be noted that modified nanoparticles are nanoparticles coated with special chemical or charged groups. This work investigated the hindering effect of silica nanoparticles on Atoka shale using the thermal stability test and pressure propagation test (PPT). It was shown that the nanoparticle solutions that pass the thermal stability test can be subjected to the pressure propagation test. The size of nanoparticles is in the range of 7 to 22 nm. The authors reported that nanoparticles in the range of 7 to 15 nm can effectively reduce the permeability of shale. The physical mechanism of the nanoparticles is by filling the throat opening of shale pores, which ultimately reduces the amount of water uptake. The authors concluded that the appropriate concentration of nanoparticles is in the range of 5% to 10%. Figure 9.14 shows a flow chart

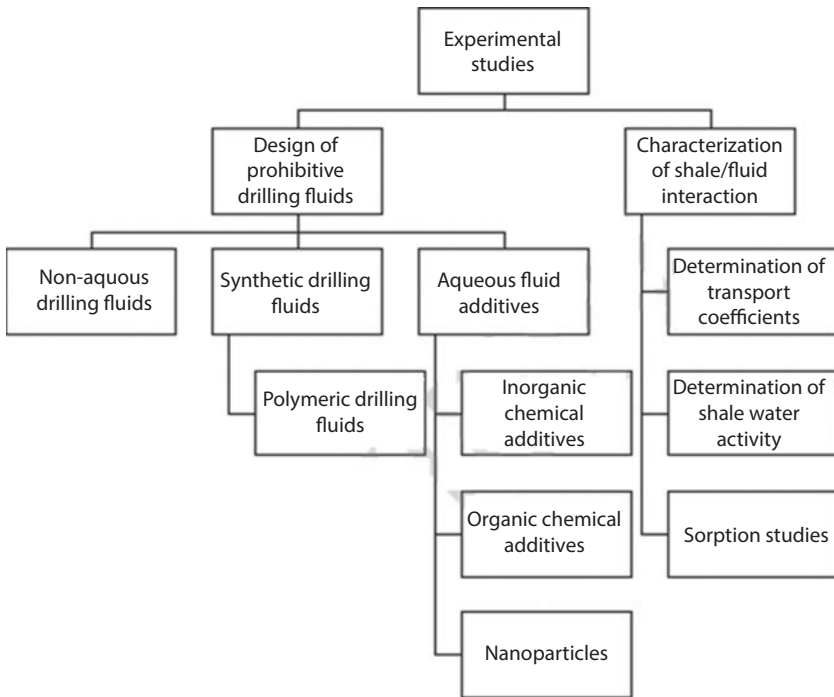

**Figure 9.14** Classification of experimental studies about shale-fluid interaction (From Adham, 2014).

for determining optimum drilling fluids for specific applications for reservoirs that have wellbore instability problems.

As new additives for drilling fluids are studied to stabilize shales, a major challenge would be to make them compatible with preserving other desirable mud properties such as, rheology, drilled solids compatibility and drilling rates.

Finally, even if we could design the best mud system for shale formations, continuous monitoring and control of drilling muds are critical elements for successful drilling. The mud composition continually changes as it circulates and interacts with formations and drilled solids. Unless concentrations of various mud additives are continually monitored (as opposed to the current practice of periodically monitoring just rheological and simple properties) and maintained, the desired results could not be achieved. The development and introduction of improved monitoring techniques for chemical measurements should proceed simultaneously with the development of more effective mud systems for shale stability, based on improved understanding of shale/fluid interaction.

## 9.2 Case Studies

In this section a series of case studies, involving wellbore instability, are presented. These specific case studies were not discussed in other chapters that discussed the problems arising from wellbore instability.

### 9.2.1 Chemical Effect Problems in Shaley Formation

Yu *et al.* (2013) reported a case study, detailing wellbore stability problem in the Nahr Umr Shale formation of Halfaya Oilfield in Iraq. The Halfaya Oilfield is in the south of Missan province in Iraq, which is 400 km southeast of Baghdad, the capital of Iraq. Comprehensive analysis of geological and engineering data indicated that Halfaya Oilfield features fractured shale in the Nahr Umr Formation. The diagnosis was performed after numerous accidents involving wellbore collapse and sticking emerged occurred in relatively high frequency. Tests and theoretical analysis revealed that wellbore instability in the Halfaya Oilfield was influenced by chemical effect of fractured shale and the formation water with high ionic concentration. Major wellbore instability problems when drilling through this shale formation have often arisen not only in new wells but also in re-entry wells, especially with the rise of water-based mud and stricter environmental control, making wellbore stability in this shale an extremely challenging operation for drilling/mud engineers.

Three horizontal wells in the Nahr Umr Formation of Halfaya Oilfield had been drilled. However, two wells of the three horizontal wells had sidetracking due to sticking, only one horizontal well was drilled successfully, demonstrating the role of angle of inclination in safe drilling.

The influence of three types of drilling fluids on the rock mechanical properties of Nahr Umr Shale was tested, and time-dependent collapse pressure was calculated. As a result of this analysis, engineering countermeasures for safe drilling were proposed that led to improved drilling operations.

### 9.2.1.1 *Geological Considerations*

The Halfaya Oilfield is located on the Arabian shelf, which is adjacent to the Zagros tectonic zone (Leturmy and Robin, 2010). The influence of Zagros tectonic movement is the extrusion to the Arabian shelf by the European plate (NNE-SSW). The propagation of the stress wave leads to a series of anticlines in the Arab shell. This extrusion stopped in Middle Miocene. The geological structure is a low dip anticline, in which the long axis is nearly perpendicular to the Zagros extrusion stress field. The structure is above the Arabian shelf and is far away from the Zagros fault control zone, but the structure is still affected by Zagros tectonic movement, which makes the in-situ stress complicated.

There is no large fault which could be recognized by seismic data. The anticline structure is also very smooth. The results show that the extrusion stress by the Zagros tectonic movement is not very strong, and the extrusion stress does not produce strong in-situ deformation and destruction.

The lithologic characters in the Halfaya Oilfield from the top to the bottom are, respectively, the Tertiary Upper Fars Group, mainly sandy mudstone, about 1300 m thick; the Lower Fars Group, mainly anhydrite, salt rock, and shale deposit, about 500 m thick, being the regional cap rock; the Tertiary Kirkuk Group which is mainly sandstone and mudstone, about 300 m; from the Tertiary Jaddala group to the Nahr Umr group, mainly carbonatite and interlayers of thin marl, sandstone and shale.

### 9.2.1.2 *Drilling Problems*

Three horizontal wells, N001H, N006H, and N002H, in the Nahr Umr Formation of Halfaya Oilfield had been drilled. The well distributions are both located in the structural long axis direction. The following are some of the major problems:

1. When the first horizontal well (N001ST well) encountered the Nahr Umr layer, there were two sidetracking operations.

The first sidetracking happened at 3941.26 m, the SLB screw stuck in the highly deviated interval and the directional tool dropped in the well. The fishing failed, which led to sidetracking. The second sidetracking happened at 4091.21 m, the Nahr Umr Shale collapsed and this led to sticking at 4087 m; the treatment measure was ineffective and a sidetracking operation took place.

2. The second horizontal well (N006ST well) used the organic salt drilling fluid, which has a strong inhibition. While drilling 3964 m, the Nahr Umr Shale collapsed and the treatment measure for the sticking failed, so sidetracking happened at 3800 m using the vertical well completion.
3. The third horizontal well N002H used saturated salt water drilling, but there were many events of stuckpipe between 3660 m and 3895 m in the Nahr Umr Formation, and there were cavings at the shaking screen.

### 9.2.1.3 Instability Mechanism

Figure 9.15 shows the logging data of the Nahr Umr Formation of N004 well. The GR logging shows that the formations are mainly sandstone and

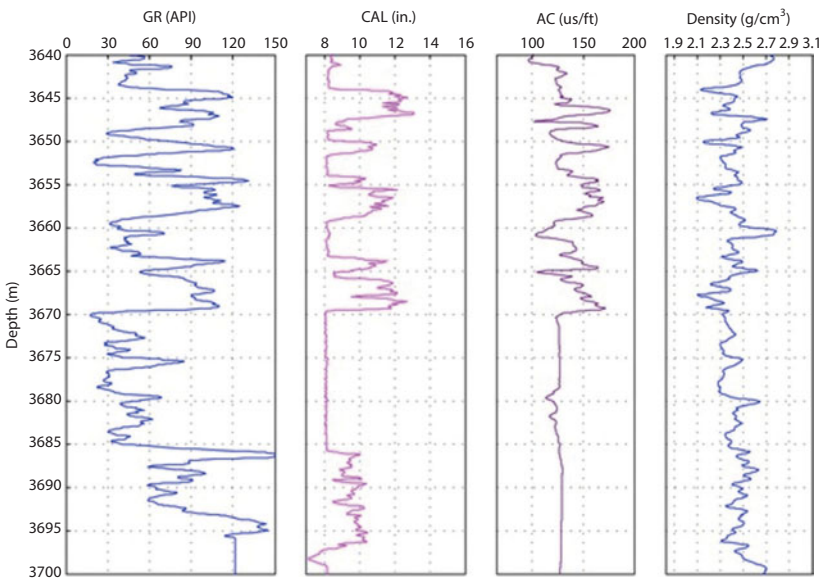

**Figure 9.15** The comparison of the logging data in Nahr Umr Formation. GR: natural gamma logging; CAL: caliper logging; AC: acoustic transit time logging.

shale. The caliper logging shows that there are both stable and unstable intervals. Compared to the GR logging data, the lithology of collapsing interval is shale and the sandstone interval is stable. Because of the presence of rich internal microfractures, drilling fluid, and the filtrate seepage, interval transit time logging data and the interval transit time of the Nahr Umr Shale is higher than the adjacent sandstone interval. Similarly, the density logging data of the shale are lower than the adjacent sandstone interval. This can be seen from the photo of the Nahr Umr Shale (Picture 9.1). The presence of shale, enriched with fractures, is manifested through the shape of cavings of the Nahr Umr Shale (Picture 9.2).



**Picture 9.1** The core of Nahr Umr Shale.



**Picture 9.2** The shale cavings of the Nahr Umr Shale of N006H Well.

The principal reason for wellbore instability in hard brittle shale with lots of fractures is the following. If the sealing capacity of the drilling fluid is not enough or the ionic concentration is not enough to balance the formation water ionic concentration, the drilling fluid and the filtrate would flow into the microfractures under the driving power from the fluid column pressure difference of drilling fluid and the ionic concentration difference. This would lead the friction coefficients of the fracture plane to decrease, the effective stresses around the wellbore to decrease, the formation around the wellbore to become loose, and the support of the drilling fluid column to the wellbore wall decrease. Thus, the formation fluid will flow into the wellbore. During the reaming and back reaming, the disturbance of the rigs to the loose formation will lead to wellbore instability.

#### 9.2.1.4 *Instability Analysis*

Wellbore stability (or instability) can be assessed through reactions to various drilling fluids. Table 9.3 shows the drilling fluid property used in these three horizontal wells. These three wells used three different types of drilling fluid. The following can be concluded from the drilling fluid property parameters in the table.

1. Based on the mud rheological parameters, for the formation with good completeness, the rheological parameters of these three wells are similar and could meet the engineering requirement. However, for the fractured shale formation, the rheological parameters of these three wells are different. Compared to the other two wells, the drilling fluid of N001H well has a low viscosity, which is ineffective for carrying the cuttings and cavings. In addition, the drilling fluid with low viscosity will easily flow into the formation under the pressure difference. Therefore, the rheological parameters of drilling fluid of N002H well benefit wellbore stability. Usually increasing the drilling fluid viscosity is of benefit for fracture formation.
2. The loss data indicate that the filter losses of these three wells are similar. Because the filter loss is measured by the experimental instrument in the laboratory, the results cannot reflect the real formation situation and it is only a reference index. This also confirms the need of conducting laboratory tests in a scaled model.

**Table 9.3** The drilling fluid properties of three horizontal wells of Nahr Umr Formation.

Mud type	Well no.			
	N001H well-hole 1	N001H well-hole 2	N002H well	N006H well
	KCL-polymer	KCL-polymer	Salt saturated	BH-WEI
Density (g/cm <sup>3</sup> )	1.25	1.25	1.28	1.28
Viscosity (s)	51	53	78	65
Plastic viscosity (cp)	26	27	41	39
Y.P (lb/100 ft <sup>2</sup> )	24	26	31	29
Gel strength 10"/10' (lb/100 ft <sup>2</sup> )	5/8	5/14	7/9	5/7
API filtrate (mL)	3.2	3.4	3.0	3
Mud cake (mm)	0.3	0.3	0.3	0.5
PH	9.5	9	9	8.5
Solid (%)	13	11	13	17
Sand (%)	0.3	0.3	0.2	0.3
Bentonite content (g/L)	27	26	38	
Potassium (mg/L)			27000	
Chloride (mg/L)			55000	11520
Ca <sup>+</sup> (mg/L)			200	

- Based on the drilling fluid ionic concentration, although there are not ionic concentration parameters of N001H well drilling fluid in the daily drilling report, according to the drilling fluid description provided by the drilling fluid service provider, the drilling fluid ionic concentrations of this well indicate that the ionic concentration of KCL Polymer drilling fluid used in the N001H well are between the concentrations of the N002H well and N006H well; the ionic concentration of the N002H well is the highest the ionic concentration of the N006H well is the lowest. When the hole is opened, the ionic concentration difference of the drilling fluid and formation water is the main driving force



**Table 9.4** The formation fluid properties of Halfaya oilfield.

	Unit	Nahr umr
Water type		CaCl <sub>2</sub>
pH		6.3
Specific gravity (15.56 °C)	sg	1.121
Resistivity (25 °C)	ohm-m	0.068
Total salinity	ppm	166661
Total hardness	mg/L	16562
Na <sup>+</sup>	mg/L	60015
Ca <sup>2+</sup>	mg/L	8681
Mg <sup>2+</sup>	mg/L	993
Fe <sup>2+</sup>	mg/L	74
Ba <sup>2+</sup>	mg/L	1
K <sup>+</sup>	mg/L	716
Sr <sup>2+</sup>	mg/L	356
Cl <sup>-</sup>	mg/L	107098
SO <sub>4</sub> <sup>2-</sup>	mg/L	874
HCO <sub>3</sub> <sup>-</sup>	mg/L	7263
CO <sub>3</sub> <sup>2-</sup>	mg/L	0
OH <sup>-</sup>	mg/L	0

behind water movement from the drilling fluid into the formation. Commonly, the high ionic concentration of drilling fluid is of benefit to prevent the free water in the drilling fluid from flowing into the formation. If the free water in the drilling fluid flows into the formation, the formation will be hydrated, and the formation strength will be decreased, so as to lead to wellbore periodic collapsing. Table 9.4 shows the formation water property of Halfaya Oilfield. The results show that the formation water has an extremely high ionic concentration, which needs a high ionic concentration for drilling fluid to balance it.

### 9.2.1.5 Shale Hydration

According to the formation character, the Nahr Umr Shale is abundant in microfractures. It is, therefore, expected that the drilling fluid can easily flow

into the micro fracture plane, leading to the change of formation strength. In order to prevent wellbore instability, the drilling fluid property should be improved. The influence of drilling fluid on the wellbore stability was analyzed from the mineral composition, the drilling fluid consistency, and the influence of the drilling fluid on formation strength.

Tables 9.5 and 9.6 illustrate the minerals and clay minerals composition and content of the Nahr Umr Shale, respectively. The test results in the tables show that the Nahr Umr Shale mainly consists of quartz and clay, especially quartz, which exceeds 48.5%. For shale Formation, the higher the quartz, the higher the brittleness; at the same time, the content of the clay minerals of the shale belongs to medium and little high level. The clay minerals mainly consist of illite/smectite and kaolinite, and the content of smectite is low. The type of the clay mineral indicates that the shale is very brittle. In addition, the kaolinite is a stable clay mineral, and the hydration of the illite/smectite is also feeble. The type and content of the clay minerals both indicate that Nahr Umr Shale Formation is a hard and brittle formation which is hard to hydrate.

Research experience of the field indicated that adequate drilling fluid inhibition shale hydration can be prevented. Therefore, the rejection capacity of three drilling fluid systems, which were used in the Halfaya Oilfield, were evaluated. The three drilling fluids are organic salt drilling fluid, Gel-polymer drilling fluid, and KCl-polymer drilling fluid.

Relevant properties are listed in Table 9.7. The results show that the cuttings recoveries of these three types of drilling fluid are both higher than 95% for the Nahr Umr Shale, although the swelling ratios are different. These results show that the inhibitive capacity of the drilling fluid is adequate, while the formation hydration is feeble. The inhibitive capacity of the drilling fluid is not the main reason for the wellbore instability of the Nahr Umr Shale.

In order to analyze the influence of the drilling fluid on the wellbore stability of the Nahr Umr Shale, experimental studies were carried out on the influence of drilling fluid on the rock mechanical property. Shale strength of Nahr Umr Shale was measured after immersing it in different kinds of drilling fluids. Table 9.8 shows the uniaxial compressive strength (UCS, MPa) results from the test. Figure 9.16 shows the comparison of the strength variation rule versus the time after immersing in different kinds of drilling fluid.

Figure 9.17 shows that the shale UCS decreases greatly after immersing it in the organic salt drilling fluid, the next is the KCL-polymer drilling fluid; the strength in the Gel-polymer drilling fluid changed a little. Therefore, the Gel-polymer drilling fluid benefits the wellbore stability of the Nahr Umr Shale.

Table 9.5 Mineral composition and content of the Nahr Umr Shale.

Depth	Mineral content (%)									
	Quartz	Potassium feldspar	Soda feldspar	Anorthose	Calcite	Dolomite	Iron pyrite	Hematite	TCCM	
3645.10	51.7	0.8	-	0.2	-	-	-	2.7	44.6	
3649.83	60.8	1.2	-	-	0.4	-	4.7	-	32.9	
3666.00	48.5	1.9	-	0.3	1.4	-	4.5	-	43.4	

**Table 9.6** Clay mineral composition and content of the Nahr Umr Shale.

Depth	Clay mineral content (%)						Interbed ratio (% S)	
	S	I/S	It	Kao	C	C/S	I/S	C/S
3645.10	-	34	7	48	11	-	14	-
3649.83	-	33	3	40	24	-	11	-
3666.00	-	44	7	49	-	-	21	-

**Table 9.7** Swelling ratio and recovery of the Nahr Umr Shale.

	Organic salt	KCL-polymer	Gel-polymer
Recovery Rate (%)	95	96	97
Swelling Ratio (%)	24	36	22

**Table 9.8** Experimental results of shale UCS after immersing in drilling fluid.

Drilling fluid type	Organic salt	KCL-polymer	Gel-polymer
UCS without immersing (MPa)	48.62	51.09	47.22
UCS with immersing of 24 h (MPa)	40.16	44.8	44.8
UCS with immersing of 48 h (MPa)	37.81	41.41	43.02
UCS with immersing of 72 h (MPa)	35.64	39.82	41.69
UCS with immersing of 96 h (MPa)	34.96	39	40.33

Under the diffusive force of the ionic concentration difference, the free water in the drilling fluid which flows into the formation would decrease the rock strength, which is the main reason for the collapse in Nahr Umr Shale. In addition, as the formation is extremely hard and brittle and the fractures are rich internally, if the drilling fluid sealing capacity is not good enough, the drilling fluid and filtrate would flow into the rock along the microfracture under the difference of the drilling fluid column pressure and pore pressure, so as to weaken the formation strength and lead to well-bore collapse. Consequently, the increasing of the ionic concentration of

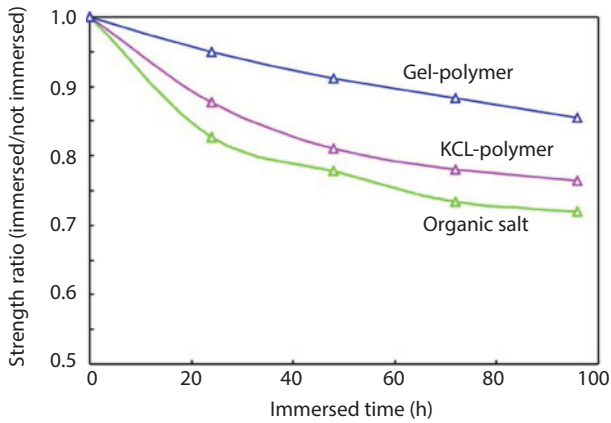

**Figure 9.16** Comparison of the shale strength decrease after immersing.

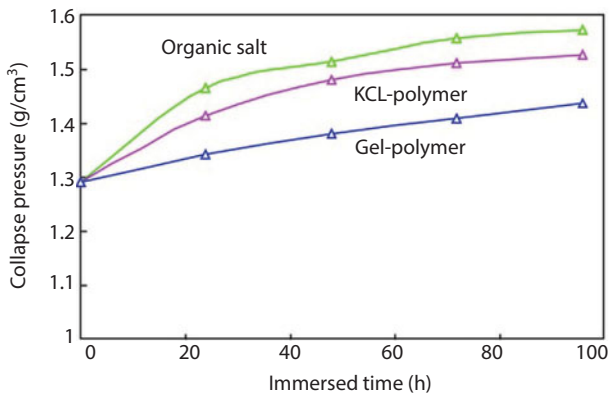

**Figure 9.17** Time-dependent collapse pressure of Nahr Umr Shale.

the drilling fluid and enhancing the drilling fluid sealing capacity is the key to the wellbore stability of the Nahr Umr Shale.

### 9.2.1.6 Dynamic Effects

According to mechanical concepts, the main reason for borehole collapse is caused by shear failure for the reason that stresses loaded on rock around the borehole exceed the rock strength, as a result of lower mud column pressure. Generally, borehole collapse takes place in the minimum horizontal stress direction,  $\theta = \pi/2$  or  $3\pi/2$ .

For the shale of the Nahr Umr Formation, according to the study results and experimental results, the influence of the drilling fluid immersion on

the mechanical property mainly reflects in the decrease of the compressive strength as the immersing time increase. Figure 9.17 shows the variation of collapse pressure versus the hole opening time for Nahr Umr Shale. The collapse pressure would increase as the formation strength decreases with the increasing speed decreases gradually. The increasing rate of Gel-polymer drilling fluid is the lowest in a certain drilling fluid density. It can keep the wellbore stability for the longest time. The increasing of the mud density could only keep the wellbore stability in limited time. If the property of the drilling fluid cannot be improved, increasing the mud density would force the drilling fluid to flow into the formation and make the wellbore unstable.

#### 9.2.1.7 *Lessons Learned from Countermeasures*

A number of lessons were learned from the experience of this formation. They are:

1. Drilling fluid viscosity alone cannot remedy wellbore instability problems in a shale formation that contains numerous fractures. If the drilling density is too high, the pore pressure would increase and the effective stresses around the wellbore would decrease, leading to a larger damage. On the other hand, decreasing the drilling fluid filter loss and improving the drilling fluid rheological property would benefit wellbore stability.
2. The larger the inclination the greater is the probability of wellbore instability. However, in the presence of the laminar fractures, decreasing the angle of the wellbore axial line with the bedding normal direction is of benefit for the wellbore stability.
3. The influences of the swabbing pressure and surge pressure should be taken into consideration when evaluating wellbore stability.
4. The hydraulic jetting is not suitable, because the high pressure hydraulic jetting would produce water wedge effect in the progress of the drilling seepage.
5. For some situations, wellbore collapse cannot be prevented, so carrying out the cuttings in a timely way could decrease the downhole idle time.
6. The formation water has an extremely high ionic concentration, requiring special countermeasures.

Based on experimental research and theoretical analysis, the following countermeasures were taken in this particular case study.

1. Decreasing the drilling fluid filter loss and improving the drilling fluid rheological property would benefit wellbore stability.
2. Decreasing the angle of the wellbore axial line with the bedding normal direction is of benefit for the wellbore stability.
3. The influences of the swabbing pressure and surge pressure should be taken into consideration when evaluating wellbore stability; the simplified bottomhole assembly (BHA) could prevent large swabbing pressure and surge pressure and then prevent sticking.
4. Avoiding hydraulic jetting or using big diameter jet can be beneficial.
5. Avoiding the intense change of the dogleg or the well track so as to prevent big drillstring acting force to the wellbore wall is helpful.
6. Hydraulic parameters should be optimized so as to ensure the cuttings could be carried out of the wellbore in a timely manner. For some situations, wellbore collapse cannot be prevented, so carrying out the cuttings in a timely way could decrease the downhole complicated time. Increasing the drilling rate could decrease the exposed time of the shale formation, which is useful for the wellbore stability.
7. In the presence of high concentration formation water, high ionic concentration for the drilling fluid should be used to balance the formation water.

### **9.2.2 Minimizing Vibration for Improving Wellbore Stability**

Larsen (2014) presented a number of case studies. One example deals with minimizing vibration in order to restore wellbore stability. In this case study a BHA configuration with an 8 ½” PDC bit was used, together with an 8 ½ 9 7/8” underreamer. In the first drilled section of the well the underreamer was inactive to quantify the difference in vibration level after the underreamer was activated. The vertical hole was drilled using two dynamic measuring tools (DMT), one above the bit and one above the reamer, to record the dynamics and loads of the bit and reamer.

The field test was initiated at a depth of 106 m (348 ft). Data were recorded to a bit depth of 152.5 m (500 ft), while the reamer was inactive. At this stage there was no significant static bending, but some drilling noise caused by the bit rock interaction was recorded. The upper DMT placed near the reamer did not show any signs of damaging vibrations. 5 m (16 ft) below the first data measurements the reamer was activated and 5.25 m (17 ft) deeper, data were again recorded. Both datasets were collected at nearly identical conditions. Due to the cutting action of the reamer, the entire BHA now experienced high level of vibration compared to when the reamer was inactive. The cutting forces generated at the reamer initiated a motion in opposite direction of the string rotation (backward whirl). Lateral movement of the string was significantly increased at the DMT close to the reamer and higher vibration levels were also recorded at the lower DMT, close to the bit. The effects of the reaming process were less significant at the lower DMT compared to the upper DMT, however it was still present. The field test clearly demonstrated that the reamer contributed to significantly increased level of vibration, bending moment and accelerations.

A second test was performed in a deviated wellbore. This BHA configuration included a RSS for directional control. The string was bent due to the curvature of the wellbore and hence the string had constant contact with the borehole wall. As concluded in the vertical well test, the upper DMT experienced more vibrations than the lower. The stabilizers were subjected to higher contact forces in the deviated well due to the curvature. These contact forces prevented the reamer from going into backwards whirl, implying that the drillstring is less susceptible to lateral movement in a deviated wellbore compared to a vertical wellbore.

In the second case study, four wells were drilled into a hard conglomerate interval. All wells used roller reamers in the section. Several trips had normally been required to drill through the interval in offset wells (not utilizing roller reamers) and whirl-induced borehole features often led to tripping problems. No problems in the footage drilled were recorded after implementing roller reamer BHAs. The roller reamers served to decouple whirl and stick-slip and thus allowed more WOB to be applied. Both level of bit whirl and the amplitude of whirl-induced patterns were most likely reduced. As it was drilled deeper, a roller reamer had to be replaced with a stabilizer, as the bearing became slightly loose and no backup was present. Bit and BHA configuration stayed the same and the stabilizer had similar dimensions to the roller reamer. When drilling with the stabilizer instead of the roller reamer, drilling progress became slow and severe surface vibrations were yet again recorded, as lateral vibrations coupled torsional vibrations.



### 9.2.3 Mechanical Wellbore Stability Problems

Adham (2016) presented a series of case studies, dealing with wellbore stability problems that can be characterized as stemming from mechanical malfunctions. In this section, we use those case studies to illustrate how mechanical aspects can play a role in wellbore stability.

#### 9.2.3.1 Case Study for Well X-51 (Shale Problems)

The location of the well is shown on the cross-sectional map in Figure 9.18. Well X-51 was proposed as development well with expected production of 2 MMSCFD gas and 30 BCFD of condensate from Besitang River Sand (BRS). Figure 9.19 shows well correlation of this well along with others that

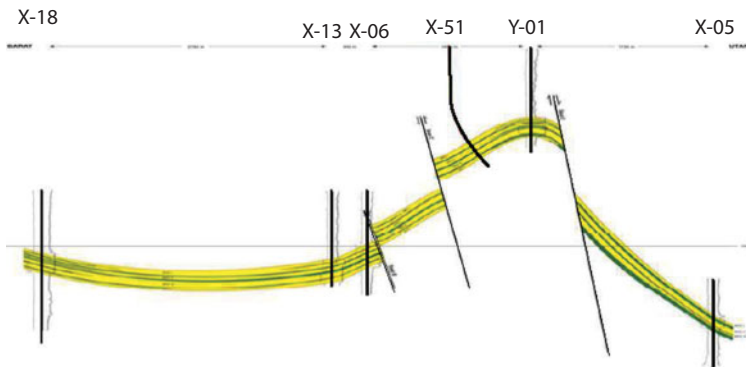

Figure 9.18 Structure correlations for BRS formation.

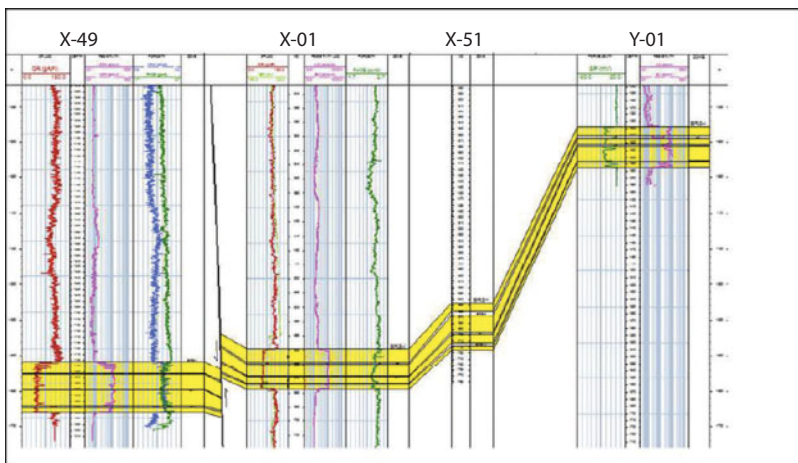

Figure 9.19 Wells correlation for BRS formation.

will also be part of this case study. This well was planned to be drilled directionally with azimuth N 330° and inclination 42.9°. Figure 9.20 shows the planned wellbore trajectory. The kick off point started at 730 m, with final depth at 1814.7 m MD (meter measured depth) or 1600 m TVD (meter true vertical depth). According to the plan, the drilling process would have taken 23 days to complete.

To reach the target depth at BRS sandstone formation, the drilling process will pass through Seurula formation, thin Keutapang formation, and the upper Baong shale formation. The Seurula formation consists mostly of sandstone, shale and clay, while Keutapang formation composed mainly of fine grained sandstone, interbedded with clay, shale, and limestone streaks.

The first drilled section was a 8 1/2” hole. The actual kick-off point for directional drilling was at 724 m MD, with the target depth at 1054 m MD. The mud weight used in this section was 1.2 (SG). Severe wellbore-stability issues were experienced while drilling this section that led to bottomhole assembly (BHA) being stuck at 1040 m MD due to pack-off. Several types of efforts were done to overcome this problem, including optimizing the mud circulation, jarring, and utilizing the dissolving chemicals, but all failed and the hole was plugged. The key operational parameter for this section is presented in Table 9.9. A new sidetrack well program was then prepared for this well with increased mud weight from 1.2 to 1.24 SG.

The first sidetrack window was drilled at 891 m MD using 1.24 SG mud weight. During this drilling process, the first indication of wellbore instabilities occurred at 1172 m MD, as evident from shale cuttings at shale

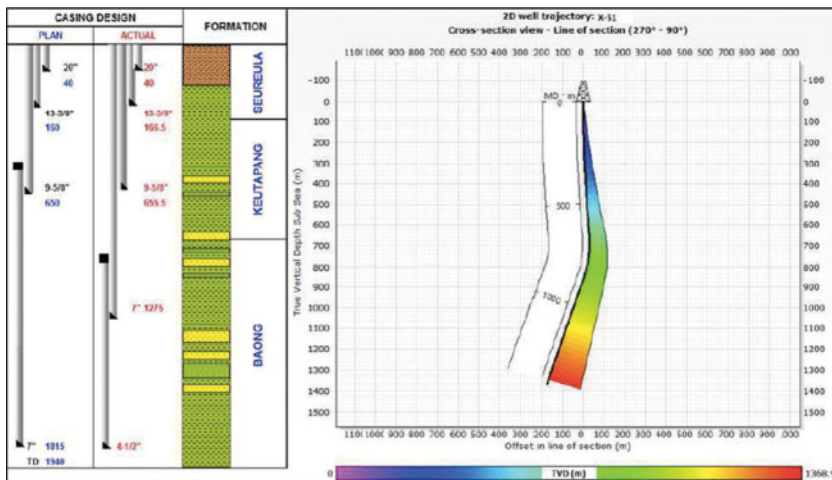

Figure 9.20 Wellbore diagram and actual wellbore trajectory X-51.

Table 9.9 Key operational parameters used for drilling in well X-51.

No.	Section	MD m	TVD m	Lithology	Azimuth	Inclination degree	Mud weight gr/cm <sup>3</sup>	Mud viscosity	Mud type
1	Eight and half inch	1040	999	shale	329.8	35	1.24	90	Oil based mud
2	Eight and half inch section (first sidetrack)	11172	1106	327.9	33	1.25	1.25	88	Oil based mud
3	Eight and half inch section (first sidetrack)	1495	1381	shale	331	31.1	1.27	95	Oil based mud
4	Eight and half inch (first sidetrack)	1478	1359	shale	331	32.1	1.27	95	Oil based mud
5	Eight and half inch section first sidetrack	1359	1260	shale	325.5	32.3	1.26	90	Oil based mud

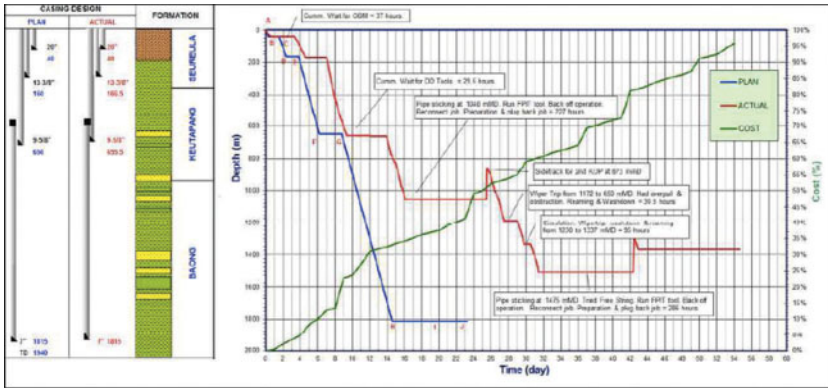

Figure 9.21 Drilling progress chart well X-51.

shakers and BHA being stuck. Optimization of mud circulation successfully freed the stuck BHA. However, while running the BHA back into the current depth, the BHA sat at 978 m MD. The drilling fluid from the wash down operation indicated that the hole was filled with shale cutting.

Another pack off and overpull occurred at 1495 m MD, the mud weight was increased to 1.3 with higher viscosity and successfully freed the stuck BHA. The follow-up pack off and overpull at 1478 m MD could not be surmounted and the BHA was cut with top of fish (TOF) at 1418 m MD, and the hole was plugged with top of cement (TOC) at 1305 m MD. The amount of shale cuttings from drilling fluid circulation indicated that they were the causes of pack off in both occurrences.

The second sidetrack window was drilled at 1305 m MD and immediately experienced overpull at 1359 m MD. Jarring, optimized circulation, wash down and reaming failed to release the stuck BHA. The well was plugged back and abandoned.

The drilling progress for X-51 (Figure 9.21) showed the time that was spent for specific depth. The depth of the unstable area can be easily recognized immediately based on the amount of nonproductive time spent at this depth.

Figure 9.22 shows that 90.5% of the non-productive time was caused by the stuck pipe incident. This percentage was very high compared to other causes of non-productive time for this well.

### 9.2.3.2 Case Study for Well X-53 (Shale and Sand Problems)

Well X-53 was planned to be a development well that was drilled from the same cluster group as well X-51. Similar to well X-51, the target reservoir

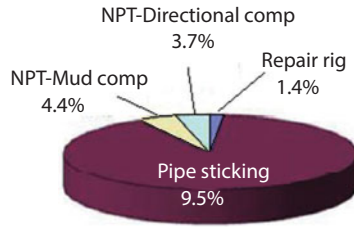

Figure 9.22 Non-productive time chart for well X-51.

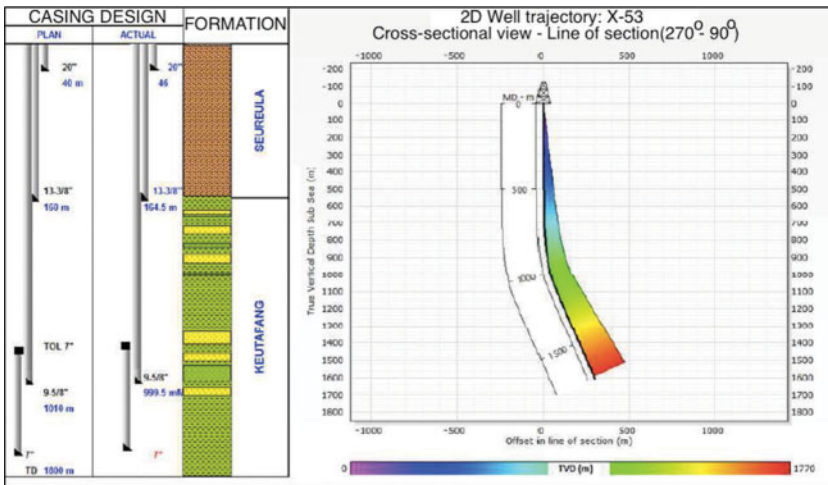

Figure 9.23 Wellbore diagram and actual wellbore trajectory X-53.

for this well is in the Besitang River Sand formation. To reach this formation, the drilling process would have to pass through Seurula formation, thin Keutapang formation, and the upper Baong shale formation. The initial plan for the well was directional with azimuth N 133.7° and inclination 35.6°. The kick-off point started at 600 m, with final depth at 1825 m MD/ 1640 m TVD. According to the plan, the drilling process would have taken 24 days to complete. The wellbore diagram is shown in Figure 9.23.

For this well, the actual directional section (8<sup>1/2</sup>"") started from the kick-off point at 580 m MD and reached 1690 m MD. The designed mud weight for this section was 1.2-1.3 SG and viscosity 45-50 cP. This mud weight was higher than what had been used in well X-51 to avoid similar problems. However, wellbore instabilities still occurred in this section. The first problem took place while pulling out the BHA with indications of pack off, which lead to stuck BHA at 1565 m MD with an overpull of 60 tons. Jarring and optimized circulation failed to release the BHA, and finally it was decided

to cut the BHA using severing tool at 1545 m MD. The wellbore was then plugged, and a new drilling program for a sidetrack well was prepared.

The new program for this well started with creating a sidetrack window at 1035 m MD. A number of well instability issues occurred during drilling this section. The first problem happened while running down the BHA for sidetrack, the string sat at 1054 m and experienced pack off, which led to stuck BHA. Large amount of shale cuttings were found at the shale shaker. Eventually, jarring successfully freed the BHA, and then the mud weight was increased from 1.56 to 1.58 SG. Another attempt to run down the BHA for sidetrack experienced pack off and drillstring sticking. After being released by jarring, the mud weight was increased from 1.59 to 1.61 SG. The next attempt to create the planned sidetrack well was hampered after a deviation from the designed trajectory was detected. This deviation was predicted to be caused by the reaming and wash down from releasing the stuck BHA. A new program with new trajectory was created.

The new drilling program running well without severe instability issues throughout the Baong upper shale formation. However, total loss occurred at 1782 m MD followed by stuck BHA. The mud weight during total loss was 1.68 SG. The efforts to release BHA eventually failed, and the string was cut at 1310 m.

The attempts to create a new sidetrack well keep failing during BHA trip, the string sat at 1042 m and was not placed into the new sidetrack borehole. There were also indications of packoff at 1020 m. The well was then plugged back at 950-1050 m MD and left as suspended well.

The drilling progress chart in Figure 9.24 shows the time that was spent for specific depth. From this chart the depth of the unstable area can be recognized immediately based on the amount of non-productive time spent

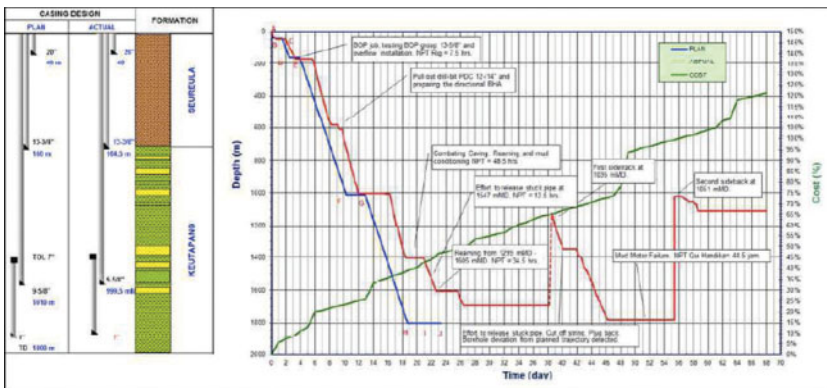

Figure 9.24 Drilling progress chart well X-53.

at a depth. Unlike well X-51, there are two types of formation where the instabilities occurred, the upper shale Baong formation and BRS sand formation. Similar to well X-51, the non-productive time chart (Figure 9.25) shows that most of the non-productive time was caused by pipe sticking. The next bigger cause of non-productive time in this well was reaming during drilling the first sidetrack well.

Mud log data were used to determine key operational parameters at the investigated depths. The lithology, mud properties, and cutting description at the problematic depths were observed. These data are listed in Table 9.10.

### 9.2.3.3 Case Study for Well X-52 (Successful Case)

Well X-52 was a development well drilled from the same cluster group as well X-51 and X-53. Unlike the other two, well X-52 successfully reached the target depth, although with some wellbore instability issues persisted. The well was drilled directional with inclination  $32^\circ$  and azimuth N  $98.3^\circ$ . The wellbore diagram is shown in Figure 9.26.

The first wellbore instability problem occurred at 1478 m MD (shale formation) with mud weight 1.27 (SG). After successfully releasing the BHA, the drilling of this section was done by using mud weight 1.28 SG until it reaches the sandstone formation (target reservoir). Another pack off happened at 1650 m MD at shale formation (below the target reservoir). Pack off detected followed by stuck BHA. The mud weight used at this section was 1.29 SG.

The mud log data show the key drilling parameter at the problematic depth, which were listed in Table 9.11. The Besitang River Sand formation was the target reservoir in this well, located right in the middle of Baong shale formation. The caliper log in Figure 9.27 shows indications of washout above and below the reservoir using mud weight 1.27–1.29 SG. Compared to other wells, the mud weight that was used in this well is higher than well X-51, but a lot lower than the mud weight of well X-53. There was still indication of loss circulation in well X-52; however, the degree of severity was much lower than well X-53.

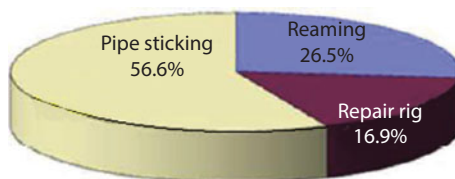

Figure 9.25 Non-productive time chart for well X-53.

**Table 9.10** Key operational parameters used for drilling in well X-53.

No.	Section	MD m	TVD m	Lithology	Azimuth	Inclination	Mud weight gr/cm <sup>3</sup>	Mud viscosity	Mud type
1	Eight and half inch	1565	1472	Shale	134.1	34.2	1.65	120	Oil based mud
2	Eight and half inch section (first sidetrack)	1782	1640	Sandstone	135.1	33.4	1.65	114	Oil based mud



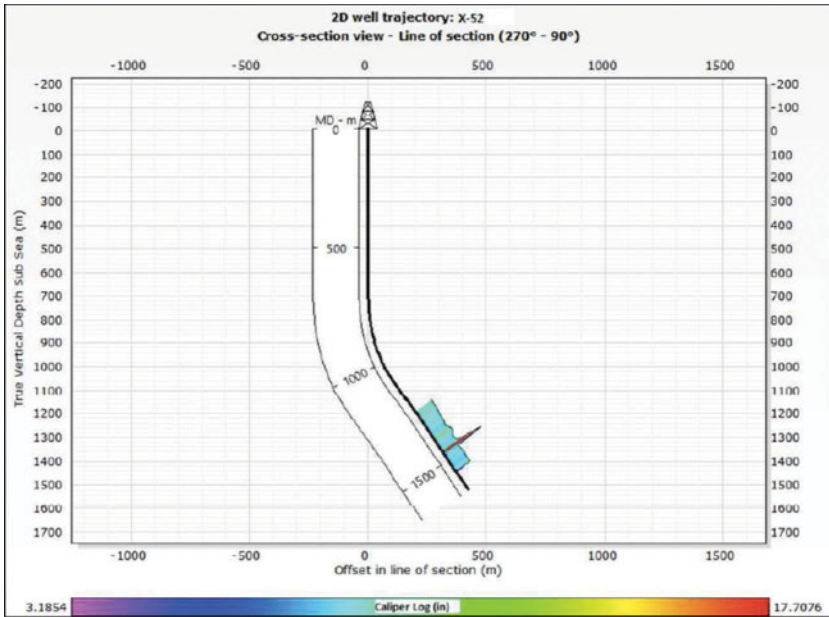

Figure 9.26 Diagram for well X-52.

#### 9.2.3.4 Lessons Learned

Based on these case studies, the following lessons are learned:

1. Wellbore instability problems occurred in all three stratigraphic units of Middle Baong.
2. Sandstone: the upper shale, sandstone, and the lower shale. This is in contrast to the commonly held belief that wellbore instability is limited to shaley formations.
3. The types of instability issues are different based on the lithology; wellbore breakouts happened in shale formation, and loss circulation happened in sandstone formation. Each of these problems will have different remedial solutions and all solutions must be considered in order to ensure smooth operations in such formations.
4. The drilling fluids properties for well X-53 cannot be used as reference due to the unmatched specification to the actual fluids. The same region can have markedly different drilling fluid requirements, hence reinforcing the notion that each well must be custom designed, based on its own lithological and fluid data.

**Table 9.11** Key operational parameters used for drilling in well X-52.

No.	Section	MD m	TVD m	Lithology	Azimuth degree	Inclination degree	Mud weight gr/cm <sup>3</sup>	Mud viscosity	Mud type
1	Eight and half inch section	1478	1380	Shale	98.3	34.5	1.27	72	Oil based mud
2	Eight and half inch section	1650	1528	Shale	98.1	33.5	1.29	70	Oil based mud

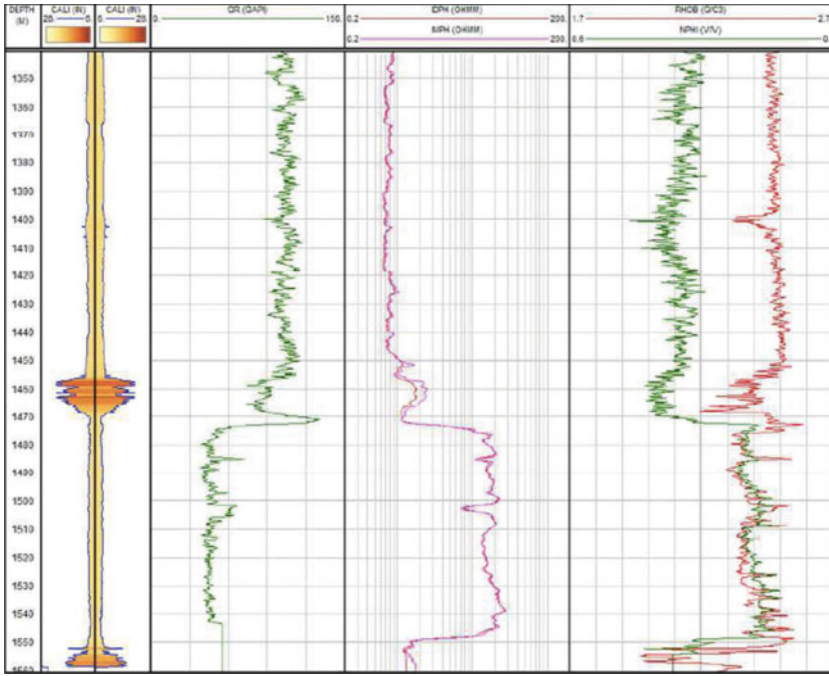

Figure 9.27 Caliper log of Well X-52.

5. All instability issues occurred at the inclined section of the well, therefore the effects of wellbore inclination needs to be analyzed. The role of inclination in aggravating the wellbore instability is well correlated and is confirmed in these case studies.
6. Proper mud weight determination is the key factor for successful drilling in these wells. In that, each well will require its own design, based on rock fluid characteristics.

### 9.3 Summary

Wellbore instability is the most fundamental property of the drilling program. In this chapter, root causes of this instability are pointed out and the end results of the wellbore instability are presented. While individual problems that arise from wellbore instability are discussed in other chapters, this chapter does present a few case studies that deal with overall instability of the wellbore.

## References

- Aadnoy, B.S. and Looyeh, R. 2011. *Petroleum Rock Mechanics: Drilling Operations and Well Design*, first edition. Oxford: Gulf Professional Publishing.
- Abduljabbar, A., Hossain, M.E., Al Gharbi, S., and Al-Rubaii, M. (2018). Optimization of Tripping Speed to Minimize Surge & Swab Pressure. SPE-189331-MS, presented at the SPE/IADC Middle East Drilling Technology Conference and Exhibition 2018, 29-31 January 2018, Abu Dhabi, UAE.
- Adham, A., 2016, Geomechanics Model for Wellbore Stability Analysis in Field “X” North Sumatra Basin, MSc Thesis, Dept. of Petroleum Engineering, Colorado School of mines.
- Agostini, C.E., Nicoletti, R., 2014, Dynamic modeling and vibration analysis of oilwell drillstring during backreaming operation, in: *T.i.M.A. I* (Ed.), Society for Experimental Mechanics Series 2014, pp. 123–131.
- Aslannezhad, M., Manshad, A.K., Jalalifar, H., 2016, Determination of a safe mud window and analysis of wellbore, *J Petrol Explor Prod Technol*, 6:493–503.
- Dokhani, V., 2014, The Effects Of Chemical Adsorption On Wellbore Stability In Transversely Isotropic Shale Formations, PhD Dissertation, Dept. of Petroleum Engineering, University of Tulsa, Oklahoma, USA.
- Dokhani V., Yu, M., Takach, N.E., Bloys, B., 2015, The role of moisture adsorption in wellbore stability of shale formations: Mechanism and modeling, *Journal of Natural Gas Science and Engineering*, 27, 168–177.
- Goud, M., 2017, *Mud Engineering Simplified*, Mumbai: BecomeShakespeare.com, ISBN 978-93-86487-67-4.
- Hakimi, H., Moradi, S., 2010, Drillstring vibration analysis using differential quadrature method, *J. Pet. Sci. Eng.* 70: 235–242.
- Hossain, M.E. and Al-Majed, A.A. (2015). *Fundamentals of Sustainable Drilling Engineering*. ISBN 978-0-470878-17-0, John Wiley & Sons, Inc. Hoboken, New Jersey, and Scrivener Publishing LLC, Salem, Massachusetts, USA, pp. 786.
- Islam, M.R., 2014, *Unconventional Gas Reservoirs*, Elsevier, 655 pp.
- Kreuzer, E. and Steidl, M., 2012, Controlling torsional vibrations of drill strings via decomposition of traveling waves, *Arch. Appl. Mech.* 82 (2012) 515–531.
- Kumar, D. *et al.*, 2012, Real-time Wellbore Stability Analysis: An Observation from Cavings at Shale Shakers, Article #41095 (2012), presented at AAPG International Convention and Exhibition, Singapore, 16-19 September 2012.
- Lal, M., 1999, Shale Stability: Drilling Fluid Interaction and Shale Strength, SPE 54356, paper presented at the 1999 SPE Latin American and Caribbean Petroleum Engineering Conference held in Caracas, Venezuela, April 21–23.
- Larsen, L.K., 2014, Tools and Techniques to Minimize Shock and Vibration to the Bottom Hole Assembly, MSc Thesis, University of Stavanger.
- Leturmy, P. and Robin, C., 2010, *Tectonic and stratigraphic evolution of Zagros and Makran during the Mesozoic-Cenozoic: introduction*, Geological Society, London, Special Publications, 330, 1-4, 1 June 2010.

- Mehdi Hajianmaleki, J.S.D., 2014, Advances in critical buckling load assessment for tubulars inside wellbores, *J. Pet. Sci. Eng.* 116.
- Mody, F.K., Hale, A.H., 1993, Borehole-stability model to couple the mechanics and chemistry of drilling-fluid/shale interactions, *J. Petrol Technol.* 45 (11) 1–93.
- Mody, F.K. and Fisk, Jr., J.V., 1996, Water-based drilling muds, US patent no. 5925598,
- Mody, F.K., *et al.*, 2002, Development of novel membrane efficient water-based drilling fluids through fundamental understanding of osmotic membrane generation in shales, in: SPE Annual Technical Conference and Exhibition, 2002. SPE77447.
- Pašić, B., *et al.*, 2007, Wellbore Instability: Causes And Consequences, *Rud. geol.-naft. zb.*, Vol. 19, 87-98.
- Yu, B., Yan, C., and Nie, Z., 2013, Chemical Effect on Wellbore Instability of Nahr Umr Shale, *Scientific World Journal*, Oct. 24, 2013: 931034, doi: 10.1155/2013/931034.
- Zhang, Q. *et al.*, 2015, A review of the shale wellbore stability mechanism based on Mechanical-chemical coupling theories, *Petroleum*, vol. 1, 91–96.

# 10

## Directional and Horizontal Drilling Problems

### 10.0 Introduction

Long before horizontal wells became ubiquitous, directional and almost horizontal drilling were common in locations where vertical wells couldn't offer adequate production efficiency. It is an irony because geologic formations are almost always much greater in horizontal extent than they are in vertical thickness. For this reason, more oil-bearing rock is exposed for production in horizontal drilling than in vertical drilling. Before horizontal wells became popular, offshore applications were prime candidates for which almost horizontal well drilling was performed and ironically each well was subsequently dropped down to vertical position. Similarly, reservoirs at locations where it is either unsafe, or uneconomical, or impossible to erect a rig above such locations, there was then a need to devise a means of accessing such target reservoirs from other locations. Ever since new-found applications of horizontal wells in heavy oil and tarsand formations that were useful solely from the perspective of drainage efficiency, horizontal well drilling caught on. Wells drilled horizontally through hydrocarbon-bearing formations are often among the most prolific oil wells in

the United States. Although modern horizontal drilling achieved commercial success in the 1980s, drilling techniques have improved, and in recent years, horizontal drilling has become more common. Since 2011, horizontal well numbers have eclipsed vertical well numbers (Figure 10.1). In 2015 nearly 77% of the most prolific U.S. oil wells, or those producing more than 400 barrels of oil equivalent (BOE) per day, were horizontally drilled wells. For about 85,000 moderate rate wells producing in 2015, defined as more than 15 BOE per day and up to 400 BOE per day, 42% were drilled horizontally. Of the approximately 370,000 lowest-rate, marginal oil wells in 2015, also known as stripper wells, only about 2% were horizontal wells (Figure 10.2).

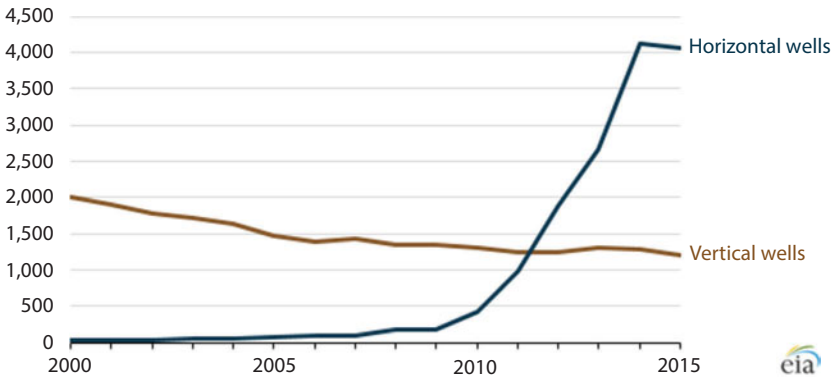

**Figure 10.1** Count of oil wells producing at least 400 bbl of oil equivalent per day (from Perrin, 2016).

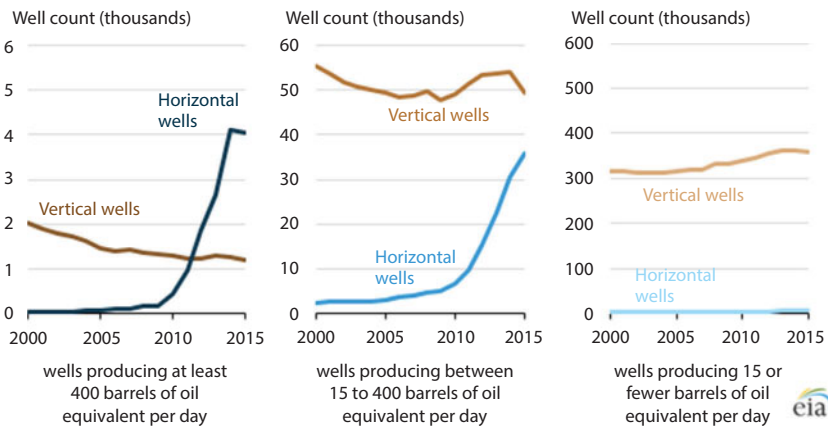

**Figure 10.2** Count of oil wells for different orientations and production rate (from Perrin, 2016).

Practically all North Sea drilling operations are with horizontal wells. In the Middle East, however, still most of the wells are vertical. During the horizontal or directional well drilling process, the in situ stresses are quite different from those of a vertical drillstring. Unlike vertical drilling that is one directional (1-D), directional drilling can be two dimensional (2-D) or three dimensional (3-D). As such drilling process undergoes complexities that are due to dynamic changes of depth, inclination from vertical direction, and the azimuth. The complexity persists with directional drilling technologies such as horizontal wells, extended reach wells, multilateral wells, slim hole drilling, and coiled tubing drilling. In highly deviated and horizontal well conditions, achieving high mud displacement efficiency requires additional special attention be given to two aspects of drilling and/or completion practice. This is necessary in order to obtain optimum mud displacement and cementing results. The two aspects are: (i) drill-fluid systems and properties, and (ii) casing and hole sizes.

Each of these aspects brings in a new set of difficulties that are not encountered during the drilling of a vertical well.

## 10.1 Problems Related to Directional Drilling their Solutions

The surge in directional wells commenced with offshore drilling for which it is a requirement to drill multilaterals from a single platform. The number of platforms can be reduced drastically with multiple directional wells instead of one vertical well per platform. After the 1980s, as horizontal well technologies blossomed, directional wells took another quantum leap. Each horizontal well has a large section that is actually directional. Directional well drilling, however, comes with a number of logistical and inherent problems. Even though numerous improvements in drilling technologies, such as downhole motors and turbines, measurement while drilling (MWD), sonic while drilling, have been made over last few decades, drilling directional wells still remains a challenging task. Soon after the inception of horizontal wells, it became common to drill a directional well with a horizontal displacement of 2–3 miles and true vertical depth (TVD) of 10,000 ft (Inglis, 1987). Figure 10.3 shows a typical directional well and how its horizontal and vertical profiles extend.

Because of the orientation, directional wells present a number of drilling problems that are different from those encountered in vertical wells. In directional drilling, gravitational forces are no longer aligned with the direction of drilling, the directional well profile leads to a new set of



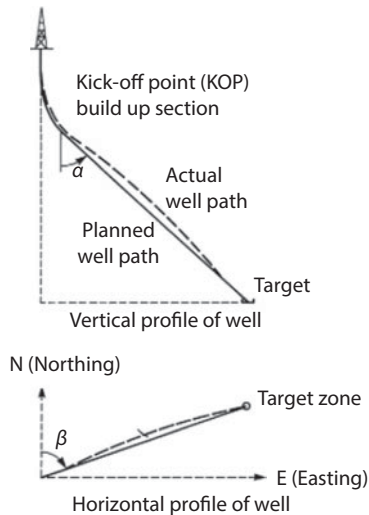

**Figure 10.3** Vertical and horizontal views of a directional well ( $a$  = inclination or draft angle;  $b$  = azimuth).

constrains. These additional problems are related to factors such as the well profile and the reduced axial component of gravity acting along the borehole. As the angle of inclination increases, drilling problems become more severe. The particular problems related to highly deviated wells (i.e., those with inclinations over  $60^\circ$ ) will be dealt with in the next section, under horizontal wells.

The most significant directional drilling problem identified by operators drilling unconventional wells has been the inability to consistently follow a prescribed well path and to hit and stay within the targets identified collectively by the company's geologists, geophysicists, and reservoir engineers. Failure to stay within optimized production zones reduces well production capability and profitability. Inaccurate directional drilling routinely leads to hundreds of thousands of dollars of lost production value per well. More importantly, any deviation from planned trajectory will likely be full of surprises in terms of terrain drilled, leading to numerous drilling problems. Drilling a directional well is already a difficult task because all the variables are dynamic and unpredictable. Attempts to compensate for deviations from the plan can lead to increased tortuosity of the final wellbore, missed reservoir, sidetracks, or unnecessary bit trips. The consequences of excess tortuosity include (i) increased drilling times; (ii) increased stress on downhole equipment leading to tool failures; (iii) future problems in running completion hardware; (iv) increased

torque and drag leading to limited reach for extended reach wells; (v) an overall reduction in total recovered hydrocarbons; and (vi) future production problems such as unanticipated high water production or liquid hold-up in low spots along the lateral section of the wellbore. All these problems have long-term implications.

### 10.1.1 Accuracy of Borehole Trajectory

The most important aspect of directional drilling is accuracy. Drilling operations require precise descriptions of the wellbore depth, trajectory and direction for guiding the drillstring, both efficiently and safely. A directional well must intersect a target that might be several kilometers away from the surface location sideways as well as thousands of meters in depth. Depth is acquired by drill pipe measurements, while inclination and azimuth are achieved from gravitational and magnetic field measurements. The reach of the target must be directed along a predetermined trajectory. Careful selection of various bottomhole assembly (BHA) is necessary as a starting point. Then monitoring tool with adaptive control of the drilling system is desired. Many factors can affect the trajectory of the drill bit. The principal factors are:

- a. formation effects (boundaries of various strata);
- b. excessive weight on bit (WOB);
- c. incorrect choice of BHA;
- d. improper calibration of the monitoring tool;
- e. The magnetic property of the drilling fluid.

The service sector of the petroleum industry possesses numerous gadgets for well positioning and navigation applications. These apparatuses differ from each other in terms of operating principles and functions. The fundamental requirement for accurate functioning of a well positioning tool is in accurate measurements of azimuth, inclination (drilling) and depth at all times. Currently, the gyroscopic survey instruments deliver the most accurate descriptions of the wellbore heading and direction. However, this survey tool is associated with time-consuming operations, technical risks and high expenses.

An alternative to the gyroscopic instruments, are the magnetic measurement while drilling (MWD) survey tools. These instruments are comprised of a transmitter module and a sensors package, which includes tri-axial magnetometers and tri-axial accelerometers installed in three orthogonal orientations, fitted in a downhole probe. The accelerometers

determine the toolface angles and borehole inclination (drilling) through measurements of the Earth's gravity, while the magnetometers determine the azimuth of the wellbore through measurements of the geomagnetic parameters. Horizontal drilling operations in the oil industry utilize the MWD technique. MWD incorporates a package of sensors including a tri-axial magnetometer and a tri-axial accelerometer mounted in three mutually orthogonal directions inserted within a downhole probe. The sensors monitor the position and the orientation of the bottomhole assembly (BHA) during drilling by instantaneous measuring of magnetic and gravity conditions while the BHA is completely stationary. A perpendicular pair or an orthogonal triad of accelerometers measure the Earth's gravity field to determine the BHA inclination and tool face angles while the magnetometers measure the geomagnetic components to determine the BHA azimuth at some predetermined survey stations along the wellbore path. The MWD survey instruments can contain errors emerging from different factors, such as (i) magnetic interference errors; (ii) calibration of sensors; (iii) inaccuracies in gravity models; (iv) bending, centralization errors; (v) ballooning; (vi) thermal elements and (vii) misalignments (Kular, 2016).

In a directional survey of wellbore, many sources of uncertainty can degrade accuracy, such as (Hadavand, 2015): (i) gravity model errors; (ii) depth errors; (iii) sensor calibration; (iv) instrument misalignment; (v) BHA bending; (vi) centralization errors; and (vii) environmental magnetic error sources.

Even though the role of drilling fluid composition (i.e., the presence of magnetic material in it) is not usually invoked in error estimations of a drilling operation, Tellefsen (2011) have conducted research to show that certain magnetic distortion relates to some drilling fluid additives. A series of experiments were conducted to increase the understanding of the effects. First a series of freshwater-based bentonite drilling fluids were investigated to see the effect of bentonite on magnetic shielding. Thereafter, a series of fresh oil-based drilling fluids were evaluated to observe the magnetic shielding effect of organophilic clays. Eroded steel (swarf) collected from the ditch-magnet of an offshore drilling location was added to the oil-based drilling fluid to investigate how swarf and steel fines content of drilling fluids affects magnetic shielding. Finally, used oil- and water-based drilling fluids were investigated. The measurements done with the oil based drilling fluid showed little or no shielding effect for the series of fluids tested. The shielding effect peaked at 0.22%, considerably less than for the water-based bentonite drilling fluids. The synthetically made organophilic hectorite clay in the oil-based fluid is known to contain little or no ferrous components capable of magnetic shielding. However, when swarf

from an offshore drilling location was added to the oil-based drilling fluid the shielding effect was 25%. This is a considerable shielding effect of the Earth's magnetic field, likely to cause substantial errors on the directional magnetic sensor in MWD tools.

Russell and Russell (1979) coined the term “heading” as the vertical direction and horizontal direction in which the BHA is pointing. The vertical direction is referred to as inclination and the horizontal direction is referred to as azimuth. The combination of inclination and azimuth at any point down the borehole is the borehole heading at that point. For the purpose of directional analysis, any length of the borehole path can be considered as straight. The inclination at any point along the borehole path is the angle of the longitudinal axis of the instrument with respect to the direction of the Earth's gravity vector when the instrumental axis is aligned with the borehole path at that point. Azimuth is the angle between the vertical plane containing the instrument longitudinal axis and a reference vertical plane, which may be magnetically or gyroscopically defined (Figures 10.4 and 10.5).

Figure 10.5 shows the measurement of the azimuth defined by a magnetic reference vertical plane, containing a defined magnetic north (Russell and Russell, 1991). The horizontal angle from the defined magnetic north clockwise to the vertical plane including the borehole axis is considered to be the azimuth. When the defined magnetic north contains the geomagnetic main field vector at the instrument location, the corresponding azimuth, referred to as “absolute azimuth” or “corrected azimuth”, is

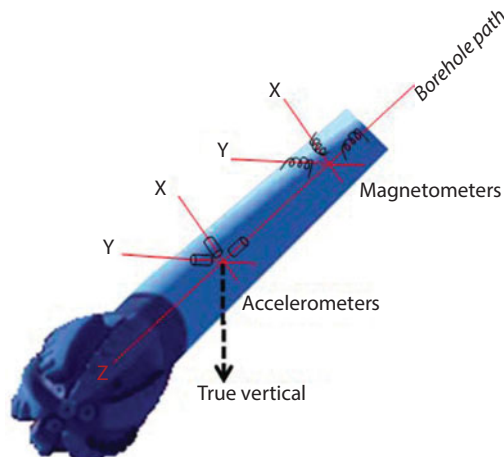

**Figure 10.4** Arrangement of sensors in an MWD tool.

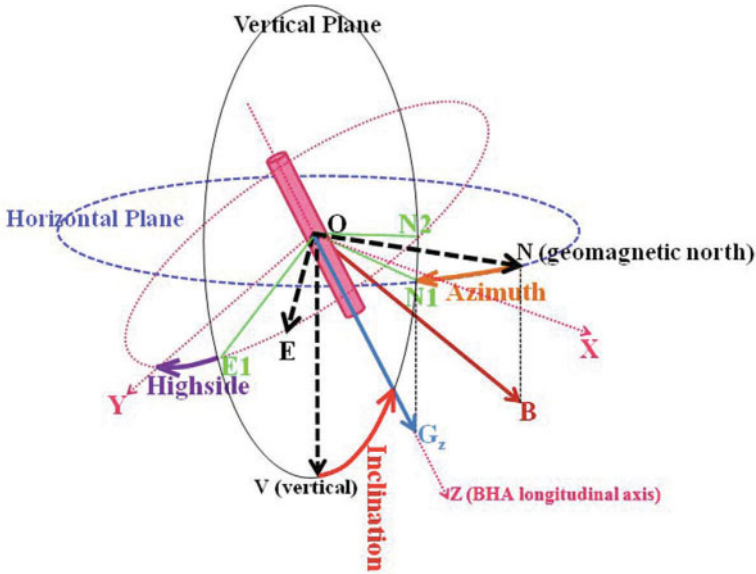

Figure 10.5 Arrangement of sensors in an MWD tool.

the azimuth value required in directional drilling process. In practice, the measured local magnetic field is deviated from the geomagnetic main field (Russell and Russell 2003), thus causing errors. The azimuth of wellbore is measured from magnetic north initially but is usually corrected to the geographic north to make accurate maps of directional drilling. A spatial survey of the path of a borehole is usually derived from a series of measurements of an azimuth and an inclination made at successive stations along the path and the distance between these stations are accurately known (Russell, 1989).

Russel and Roesler (1985) reported that drilling assembly magnetic distortion could be mitigated but never entirely eliminated by locating the magnetic survey instruments within a non-magnetic section of drillstring called Non-Magnetic Drill Collars (NMDC) extending between the upper and lower ferromagnetic drillstring sections. This method brings the magnetic distortion down to an acceptable level if the NMDC is sufficiently long to isolate the instrument from magnetic effects caused by the proximity of the magnetic sections of the drilling equipment, the stabilizers, bit, etc., around the instrument (Russell and Russell, 2003). Since such special non-magnetic drillstring sections are relatively expensive, it is required to introduce sufficient lengths of NMDC and compass spacing into BHA. Russell and Russell (2002) reported that such forms of passive

error correction are economically unacceptable since the length of NMDC increases significantly with increased mass of magnetic components of BHA and drillstring, and this leads to high cost in wells which use such heavier equipment.

Since in conventional magnetic instruments the azimuth read by the compass is determined by the horizontal component of the local magnetic field, all magnetic surveys are subject to azimuth uncertainty if the horizontal component of the local magnetic field observed by the instrument at the borehole location is not aligned with the expected magnetic north direction. Noureldin (2002) determined that the following requirements are necessary for successful drilling operation:

1. Determination of the initial azimuth at the vertical section of the well. After the establishment of the vertical section of the well to an appropriate depth, the MWD surveying systems should be capable of determining the BHA initial azimuth and accurately monitor the azimuth changes while rotating the whole drill pipe around its central axis towards the desired azimuth direction. The present MWD magnetic surveying system suffers from the deviation of the Earth's magnetic field due to the steel casing of the vertical well. Therefore, insensitivity of the monitoring devices to magnetic fields is imperative to ensure accurate initial azimuth.
2. Collision avoidance with nearby wells at sections of multi-well structure. In some drilling sites, especially for offshore drilling operations, all wells are clustered together due to the limited area of the platform. Therefore, the azimuth direction is critical to avoid collision with nearby wells and it should be precisely estimated. The MWD magnetic surveying system suffers from the deviation of the measured Earth's magnetic field in this multi-well structure due to the casing of the adjacent wells. Thus, MWD monitoring devices independent of magnetic fields are essential for successful drilling operations.
3. MWD near-bit surveying. A new trend in the drilling industry is near-bit surveying that guarantees accurate computation of the surveying parameters. The present MWD surveying system is currently located 50 feet behind the drill bit, thus it is not affected by the rotations performed by the bearing assembly located right behind the drill bit. It has been reported that mounting the MWD surveying

equipment closer to the drill bit would be highly beneficial in providing reliable MWD surveying data, especially in sections of multi-well structure. The recent near-bit MWD surveying was only introduced to provide accurate computation of the BHA inclination angle and TVD [Muritala *et al.*, 2000; Berger and Sele, 2000; Skillingstad, 2000] by mounting the accelerometers inside the bearing assembly behind the drill bit. However, it is highly desirable to provide near-bit azimuth computation as well in order to keep the BHA within its desired path.

4. Accurate surveying of the highly inclined and the horizontal well sections. As the BHA approaches the oil reservoir at high inclination angles, it is highly crucial to have accurate surveying data. Clary *et al.* (1987) reported that an error of  $0.5^\circ$  while estimating the inclination angle near  $90^\circ$  inclination could move the intersection of the target several hundred feet. Unfortunately, the present MWD surveying systems suffer from the increase of inclination errors at high inclination angles. Therefore, some methods should be developed to keep these errors as minimal as possible.
5. Continuous MWD surveying. As explained earlier, the present MWD surveying system interrupts the drilling process at some predetermined surveying stations to provide the inclination and the azimuth angles. This increases the total rig time and consequently the overall cost of the drilling process. Continuous surveying is therefore highly desirable to reduce the cost associated with increasing the time of drilling operation and to provide the exact BHA trajectory for the entire drilling process.

The major weaknesses of the present MWD surveying instruments stem from the use of magnetometers to monitor the azimuth and from the hostile environment in which these devices must operate. The problem encountered with the use of magnetometers is the presence of massive amount of steel around the drilling rig. The abundance of ferromagnetic material necessitates the separation of the magnetometers by non-magnetic drill collars. The cost of non-magnetic drill collars can run higher than \$30,000 for a single installation. Aside from the cost of utilizing non-magnetic drill collars, their use introduces a second problem. Since the non-magnetic drill collars impose an additional weight on the drill bit, the surveying tools are separated from the bearing assembly and the drill bit by about 50 feet.

The elimination of the non-magnetic drill collars could reduce the distance between the instrument package and the drill bit and facilitate the trend of near-bit surveying. The third problem associated with the use of magnetometers is their lack of reliability when used underground due to the deviation of the Earth's magnetic field from ore deposits.

A replacement for the magnetometers has been suggested. The present commercially available navigation devices such as mechanical gyroscopes and ring laser gyroscopes cannot be adopted for the downhole drilling application. Mechanical gyroscopes contain moving parts, which cannot perform properly in the harsh environment existing downhole. In addition, they are of relatively small MTBF (9000 hrs) with high drift rates and need frequent calibration and maintenance. Although the ring laser gyroscopes are of high accuracy, their size is larger than the minimum instrument size allowed for downhole applications.

#### *10.1.1.1 Guidelines and Emerging Technologies*

One of the best insurances against the geomagnetic referencing uncertainty is a site survey to map the crustal anomalies (local magnetic parameters) using In-Field Referencing (IFR) and remove geomagnetic disturbances using the Interpolated IFR (IIFR) method. Magnetic interference of drilling assembly is compensated through various methods such as a multiple-survey correction in order to reduce positional survey uncertainty.

Reduced separation between adjacent wells is allowed as a result of the overall reduced position uncertainty. A drilling engineer's ability to determine the borehole trajectory depends on the accumulation of errors from wellhead to total path. In modern magnetic surveys with MWD tools, the two combined effects of accumulated error may reach values of 1% of the measured well depth, which could be unacceptably large for long wellbores. To place wellbores accurately when using MWD surveying tools, the modern industry has promoted the development of rigorous mathematical procedures for compensating various error sources. As a result, the general wellbore positional accuracies available in the industry are of the order of 0.5% of the wellbore horizontal displacement.

Noureldin (2002) investigated whether the fiber-optic gyroscope (FOG) could be suitable for downhole drilling applications. This type of gyroscope is superior to its mechanical counterpart since it contains no moving parts, thus allowing for high reliability (high MTBF) with no need for frequent calibration or maintenance. In addition, the FOGs exhibit low environmental sensitivity since they can withstand relatively high temperatures, shocks and vibrations. Moreover, currently available FOGs are of small size



(1.6" diameter) with a drift rate less than 0.1°/hr, angle random walk less than 0.005°/hr, long MTBF (60000 hrs), no gravitational effects and excellent immunity to vibration and shock forces.

Noureldin (2002) developed a new MWD surveying methodologies based on the inertial navigation techniques for integrating the FOG technology with the three-axis accelerometers to provide complete surveying solution downhole. Inertial navigation systems (INS) determine the position and the orientation of a moving platform using three-axis accelerometers and three-axis gyroscopes forming what is known as inertial measurement unit (IMU). Since the BHA cannot accommodate a complete IMU, he utilized some specific conditions related to horizontal drilling operations to minimize the number of gyroscopes so that only one or two high-accuracy FOGs would be sufficient to provide full surveying solution downhole. In addition, some adaptive filtering techniques are utilized to enhance the FOG performance in order to reduce its output uncertainty. Moreover, applied optimal estimation techniques based on Kalman filtering methods are employed to improve the surveying accuracy. This FOG-based MWD surveying techniques eliminate the costly nonmagnetic drill collars in which the presently used magnetometers are installed, survey the borehole continuously without interrupting the drilling process and improve the overall accuracy by utilizing some real-time digital signal processing techniques.

### 10.1.2 Fishing with Coiled Tubing

Improved coiled tubing (CT) technology, development of specially designed hydraulically actuated service tools, and increased emphasis on cost efficiency have made coiled tubing a viable option for many fishing jobs. Before the emergence of coiled tubing fishing technology, traditional service procedures included use of wireline to retrieve fish from oil and gas wells. If wireline was unsuccessful, a rig or hydraulic workover (snubbing) unit had to work over the well and remove the fish.

The capability of CT to circulate fluids at the fish and generate high downhole forces enables the retrieval of fish in situations that would not be possible or cost effective by other service options. CT fishing can be performed under pressure on live, highly deviated or horizontal wells; the job can be completed and the well returned to production within 1 to 3 days for only a fraction of the cost of a workover. CT has three major advantages over wireline for fishing operations:

1. It has the capability to circulate various wash fluids, including nitrogen and acid, at high pressures to wash, jet, or dissolve sand, mud, scale, and other debris off the top of the fish.

2. It has the capability to generate large axial forces in straight or highly deviated wells for jarring and/or pulling a fish that is too heavy for wireline.
3. It can perform the above operations concurrently.

One way to compare the efficiency of fishing with Coiled Tubing versus wireline is to approximate the available energy in each system. This can be done by investigating the internal strain energy equation,  $U$ , for an elastic member of uniform cross section:

$$U = \frac{F\delta}{2} \quad (10.1)$$

where

- $\delta$  = the axial deflection of the member
- $F$  = the tensile load on the member

Deflection,  $\delta$  of an elastic member of uniform cross section is defined by the following equation:

$$\delta = FL/AE \quad (10.2)$$

where

- $A$  = the cross-sectional area
- $E$  = the modulus of elasticity
- $L$  = the unloaded length of the elastic member

Also of interest is the spring rate,  $k$ , of an elastic member of uniform cross section which is defined by the following equation:

$$k = \frac{F}{\delta} = \frac{AE}{L} \quad (10.3)$$

### 10.1.3 Crookedness of Wells/Deflection of Wells

There is rarely any straight well due to the presence of penetrate bedding planes and other geological features that make it impossible to create a straight hole, irrespective of the technology used. However, the degree of borehole deviation and tortuosity varies from location to location, In addition to natural drift, drilling practices can also create boreholes with dog-legs or other irregularities in shape or direction, which also might go undetected until they impede operations.

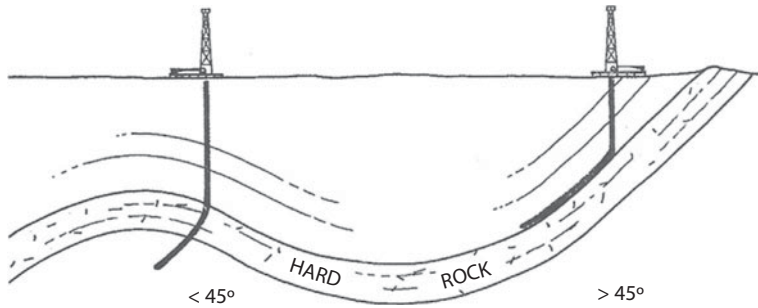

**Figure 10.6** Cause of crooked well.

An early attempt was made to define a crooked hole, which was not too successful. It is not uncommon to find such crookedness in vertical wells. However, it is far more common to have doglegs in directional wells. In this process, the degree of crookedness as measured by the magnitude of doglegs and frequency therefore are important in determining the potential problems that may be encountered during the drilling process. As such, the term crookedness in drilling is defined as: “a wellbore that has been drilled in a direction other than vertical” or as an “Antiquated term for a deviated wellbore, usually used to describe a well deviated accidentally during the drilling process,” or yet another definition, “A wellbore that is not vertical. The term usually indicates a wellbore intentionally drilled away from vertical”. If the bit hits a subsurface rock layer with a dip greater than 45 deg., the bit tends to be deflected down dip. If rock layer dip less than 45 deg., the bit tends to be deflected up dip as shown in Figure 10.6.

In general, crookedness of a borehole is determined through surveys that measure the departure of a borehole from the vertical. Of course, for horizontal wells, the measurement should be made from the horizontal direction because the standard sought is the horizontal borehole. When a well plan dictates the drilling of a straight borehole, surveys are periodically taken to ensure that it will hit its target and also to ensure that it does not trespass underneath different property lines. The same principle applies to horizontal or directional wells. These surveys can be taken fairly simply with a mechanical drift recorder more commonly known as a Totco or Totco barrel (named after the company that perfected the device). This device is run inside the drillstring attached to a wire on a wireline unit, down to the bottom of the drill pipe where the device measures the angle of the hole and then is pulled back out to visually inspect to determine the angle. There are versions of this device that actually take a picture on film and are often used in situations where the azimuth (direction) needs

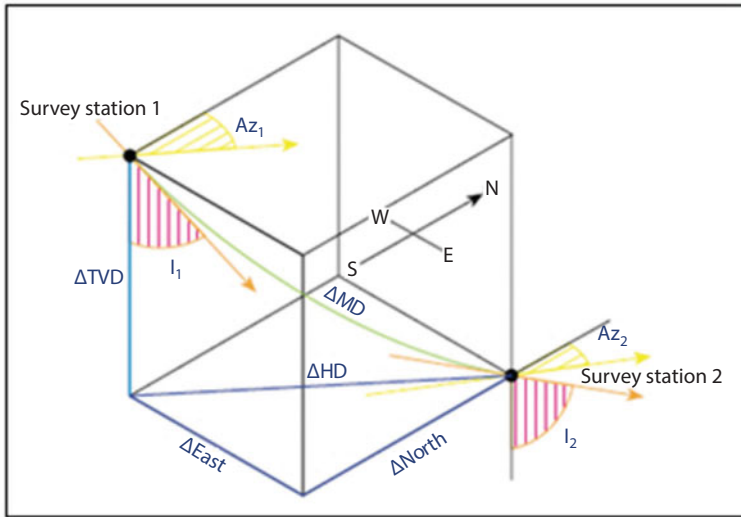

**Figure 10.7** Schematic of the directional survey.

to be determined. When a well plan dictates a directional or horizontal borehole, more sophisticated tools are normally used. One such tool is the MWD (measurement while drilling) tool that uses electronic accelerometers and gyroscopes, to continually take surveys while drilling (as the name suggests) and also measures the azimuth (Figure 10.7). This tool is attached to the drillstring itself and requires extra support personnel to use and interpret the data, and its costs are much more substantial.

#### 10.1.3.1 Causes of Crookedness

There is no exact reason why the drill bit deviates from its intended path. Whether it involves drilling a straight or curved-hole section, the tendency of the bit to walk away from the desired path can lead to drilling problems such as higher drilling costs and also lease-boundary legal problems. The following factors might be some of the reasons for the drill bit to deviate: (i) heterogeneous nature of formation and dip angle; (ii) drillstring characteristics, specifically the bottomhole assembly (BHA) makeup; (iii) stabilizers (location, number, and clearances); (iv) applied weight on bit (WOB); (v) hole-inclination angle from vertical; (vi) drill-bit type and its basic mechanical design; (vii) hydraulics at the bit; and (viii) improper hole cleaning.

There are many causes behind a crooked borehole. Here we present the most important ones. Hole deviation is the unintentional departure of the drill bit from a preselected borehole trajectory.

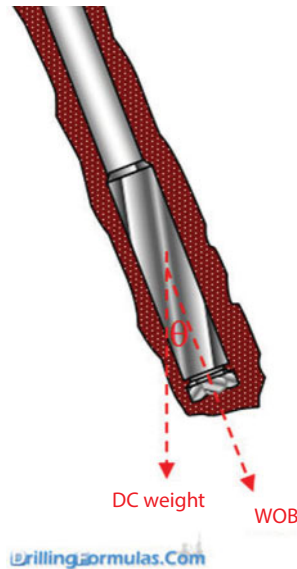

**Figure 10.8** Weight on bit and weight on drill collar.

**(1) Improper Weight on Bit:** The most important reason for crookedness of a wellbore is the high weight on bit (WOB). Because a drill bit to cut rock must be put under pressure, the drill bits used in these operations are forced against the bottom of the wellbore by the weight of the entire drillstring and, in particular, specially designed heavy tube sections known as drill collars. This weight on bit is contrast to the drillstring that must remain under tension because the direction of drilling cannot be controlled if the drillpipe is under compression. It is the weight of the drill collar that imparts weight on bit and is crucial in navigating the drill bit. During directional drilling, weight of the drill collar is not aligned with the weight on bit (Figure 10.8). As shown in Figure 10.8, the non-alignment between these two directions creates a delicate source of imbalance that can easily lead to crookedness.

**(2) Formation Dip:** The dip is the angle that the structural surface or bedding plane or fault surface makes with the horizontal (Figure 10.9). It is measured perpendicular to the strike and in the vertical plane. At the interface of the interbedding, there is invariable change in the lithology that impacts the direction of the drill bit, thus affecting both the direction and ROP. This change in ROP creates a scenario that gives the local phenomena more control over the direction of drilling than what can be

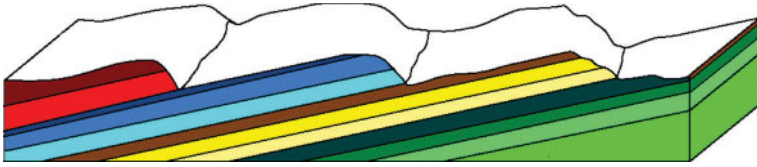

Figure 10.9 Dipping formation.



Figure 10.10 Anisotropic formation.

planned with the precalculated WOB from the Derrick. The dip of the formation is thus the second most important factor that renders a borehole crooked.

**(3) Anisotropy:** Most formations have vertical to horizontal permeability anisotropy with vertical permeability being much less (often an order of magnitude less) than horizontal permeability. Bedding plane permeability anisotropy is common in the presence of natural fractures. Stress anisotropy is frequently greatest between overburden stress and horizontal stress in the bedding plane. Bedding plane stress contrasts are common in tectonically active regions. Permeability anisotropy can sometimes be related to stress anisotropy. Anisotropy in real oil field is non-existent, and the use of the assumption of isotropy is academic. However, for practical purposes, bulk calculations can be performed based on the assumption of isotropy. This assumption breaks down both in small scale as well as in megascale (Figure 10.10). The outcome of this fact is the existence of local variations that are not detectable from the surface.

The most common directionally dependent properties are permeability and stress. The parameters that are related to anisotropy are: (i) density; (ii) porosity and permeability; (iii) strength; (iv) deformability; (v) abrasivity; (vi) environmental reactivity.

Because each of the above parameters affect the overall dynamics of a drilling program, it becomes a difficult task to monitor and control drilling during the passage through an anisotropic formation. Most geological materials are anisotropic as a result of the way in which they were formed

or deposited. Thus, most sediments are bedded, metamorphic rocks may have lineations or foliations and igneous rocks may be banded, so that the properties of the materials vary with the internal structure and texture of the material. In some cases, the internal anisotropy may be so slight as to be insignificant and for all practical purposes the material may be considered to be homogeneous and isotropic. As stated earlier, much of the background theory of soil mechanics and rock mechanics is based on the assumption that the materials dealt with are isotropic and homogeneous. In certain clearly anisotropic materials, such as schists, slates and shales, and layered sediments, variations in material properties due to anisotropy may be of vital importance in certain projects.

**(4) Inadequate Length of Drill Collars:** A component of a drillstring that provides weight on bit for drilling. Drill collars are thick-walled tubular pieces machined from solid bars of steel, usually plain carbon steel but sometimes of nonmagnetic nickel-copper alloy or other nonmagnetic premium alloys. Gravity acts on the large mass of the collars to provide the downward force needed for the bits to efficiently break rock. Appropriate length of drill collars must be used in order to ensure (i) weight on bit (WOB); (ii) BHA directional control; (iii) hole size integrity; (iv) drill string clearance; and (v) drill string compressive and torsional loads. When the drill collars are too small, any malfunction of the above factors can render the borehole crooked.

**(5) No Stabilizer or Ill Positioning of Stabilizers:** A drilling stabilizer is a piece of downhole equipment used in the bottom hole assembly (BHA) of a drillstring. It mechanically stabilizes the BHA in the borehole in order to avoid unintentional sidetracking, vibrations, and ensure the quality of the hole being drilled. Stabilizer placement is highly important to avoid drillstring vibrations and to secure safe drilling. When placing a stabilizer, a centralized location with minimal lateral displacement should be chosen, to minimize stress at the contact points. Tools, such as measuring devices, have predefined placement and should be positioned first. When these components have been placed within the assembly, stabilization placement should be evaluated. The stabilizers should be positioned at the optimum stabilization contact location. Best practice is normally to place a stabilizer near the bit, as close spacing of the first support will provide lower vibration levels. Ideally, the stabilizers should be relocatable, amenable to adjustments in spacing and hence deliver the BHA with lowest possible vibration indices. Development of relocatable stabilizers should be made a priority to achieve optimum dynamic performance objectives.

The length between stabilizers is a factor of relevance. Increased length between stabilizers or other contact points often result in lateral vibrations, as the drillstring can move sideways more freely. A maximum span length should be established to avoid lateral bending of unsupported sections. The number of stabilizers will also affect the incidents of vibrations, and lack of stabilization in slick and pendulum assemblies often leads to whirling. This will lead to loss of control over the direction of drilling.

A packed BHA, with several stabilizers, provides more stable drilling than a slick BHA, without stabilizers, as an unbalanced assembly has fewer restrictions. A stiffer drillstring will be able to withstand vibrations to a larger extent. However, it should be noted that multiple stabilizers may put constraints on the directional objectives, due to decreased flexibility. In addition, more torque can be generated at the contact points and hence torsional vibration and stick-slip may become a problem. In such cases roller reamers can come to good use.

Whenever possible, the number of undergauge stabilizers should be minimized, as they enable detrimental contact with the borehole wall if a small displacement is initiated. Some stabilizer types can potentially increase the risk of experiencing severe shock and vibrations. Flex stabilizers are most often placed above the rotary steerable tools to facilitate rotary steerable directional objectives. Flex stabilizers normally comprises a stabilizer with a smaller diameter connecting flex sub. This component can increase the lateral vibration level, as it increases the flexibility due to reduced OD. Compensating design changes should be made to the BHA if a flex sub is needed for directional objectives. Such measures could reduce the span length between the stabilizers or place the flex stabilizer closer to the bit, to offset the increased flexibility. Alternatively, if a flex stabilizer can be avoided, one should consider replacing it with a standard non-flex stabilizer, to make the BHA stiffer and thereby reduce the risk of experiencing detrimental vibrations.

#### *10.1.3.2 Outcomes of Crooked Borehole and Possible Remedies*

Complete control of borehole direction cannot be obtained during drilling, and most straight-hole drilling methods attempt to resist hole deviation rather than control direction. The process of directional drilling is particularly challenging because the bit tends to walk while drilling – a process that is highly sensitive to formation dip and rock properties. In addition, vibrations play a pivotal role. This can cause both technical and legal problems. Reduction of hole deviations is vital in order to minimize operational costs. There are a number of immediate problems related to a



crooked well. They are: (i) uneven spacing (on bottom); (ii) legal problems; (iii) production problems; and (iv) cementing problems.

The first three items are beyond the scope of this book. The fourth item has been discussed in other chapters. Specifically, for horizontal and directional wells, the cementing problem is particularly acute due to eccentric annulus. In this situation, the cement slurry flows more easily and faster through the wider annular gap. In the narrower gap, displacement lags behind and may be incomplete. This non-uniform annular fill-up and/or incomplete cement placement in the annulus can lead to unreliable zonal isolation. The problem of eccentric annulus is accentuated in horizontal wells, for which gravitational forces affect the centralization of casing string and promotes solids settling from the drilling fluids. All these abnormalities can lead to poor mud displacement during cementing. In addition, extended reach and horizontal wells are vulnerable to inadequate cement density. When a displacing fluid with higher density than the displaced fluid is used, the lighter mud in the narrow part of the annulus will float up into the wide part and be transported away with ease; this would create inhomogeneity, particularly in a crooked well.

In seeking a method to minimize hole deviations, some of these factors can be controlled while others cannot, because of technical and/or operational limitations. Hole deviation depends on many factors such as: (i) hole pattern ((length, inclination and diameter of hole); (ii) drilling equipment (rods, bits, etc.); (iii) drilling parameters (thrust, torque, penetration rate, rotation speed, drill string weight, etc.); (iv) rock (hardness, structure, etc.); (v) operator (experience, care, etc.). Remedies for hole deviation and directional control: (i) lower WOB; (ii) slow the rotation; (iii) change the BHA, and (iv) add stabilizers.

Additionally, special consideration will be given to operating parameter changes within horizontal and slanted well profiles. In order to avoid a crooked borehole, the following precautionary measures can be taken:

1. Use "Oversize" Drill Collars
2. Use Reamers and Stabilizers
3. Start the Hole Vertically

In case the borehole is already crooked, the following remedial actions can be taken:

1. Plug Back and Sidetrack
2. Use Whipstock
3. Use Reamers

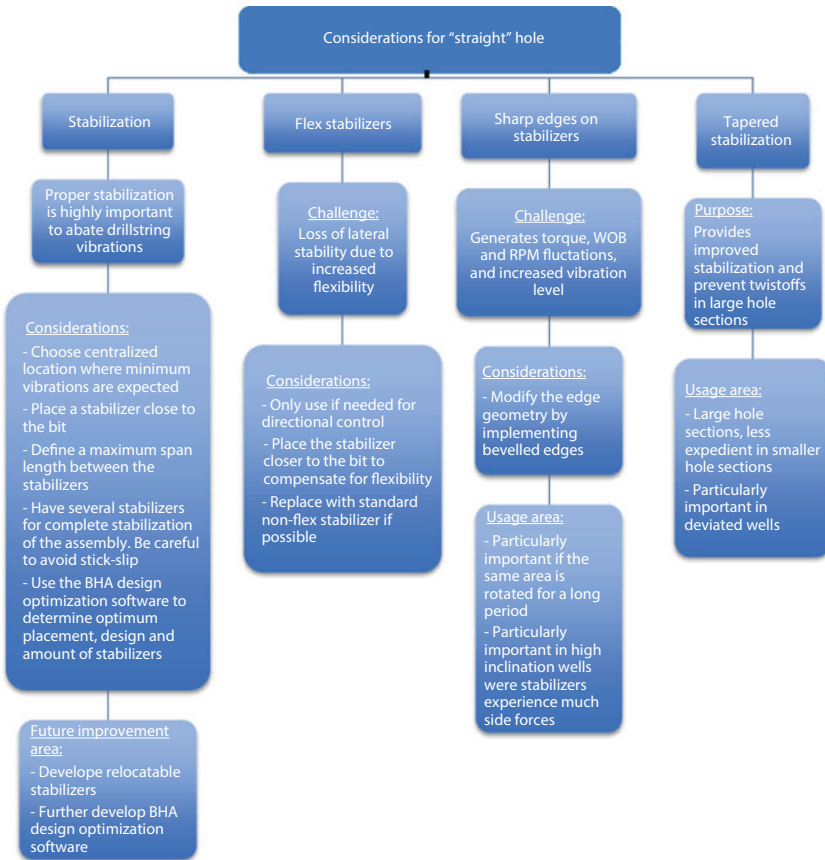
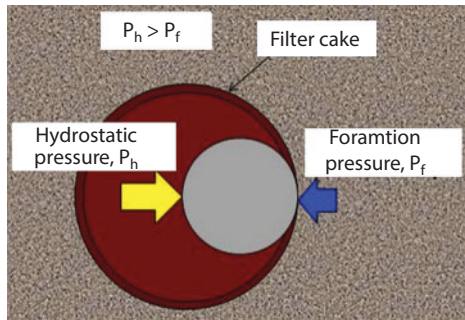

Figure 10.11 Flow chart of well management.

As Larsen (2014) pointed out, a straight hole can be drilled only when vibrations within a drillstem are minimized. Figure 10.11 sums up some of the considerations that should be made for drilling a straight hole.

### 10.1.4 Stuck Pipe Problems

As we have seen in Chapters 2 and 6, a pipe is considered stuck if it cannot be freed from the hole without damaging the pipe, and without exceeding the drilling rig’s maximum allowed hook load. Pipe sticking can be classified under two categories: differential pressure pipe sticking and mechanical pipe sticking. Mechanical sticking can be caused by local phenomena (such as, junk in the hole, wellbore geometry anomalies, cement, key seats or a buildup of cuttings in the annulus. On the other hand, differential pressure



**Figure 10.11** Differential pressure induced pipe sticking.

pipe sticking relates to differential pressure between the hydrostatic pressure of mud and formation pressure of mud while the hydrostatic pressure is greater than the formation pressure which causes encroachment of a drill string into a filter cake of permeable formation (Figure 10.11). When the differential sticking occurs, running the pipe string in the upward and downward direction is impossible, but free circulation is easily established. This problem is independent of the orientation of the borehole.

The causes of mechanical pipe sticking are the inadequate removal of drilled cutting from the annulus; borehole instabilities, such as hole caving, sloughing, or collapse, plastic shale or salt sections squeezing (creeping), and key seating (Figure 10.12). Each of these incidents is intricately linked to orientation of the borehole and as such contributes to potential drilling problems with direction wells.

In a directional well, the ledges play a significant role. Ledges occur while drilling in sequential formations that have soft, hard formations, and naturally fractured formations. Stabilizers in BHA and tool joint easily wear soft formations and naturally fractured formations, however, the hard formations are still in gauge (hole size not change). If there are a lot of ledges in the wellbore, the drillstring can get stuck under ledges. Figure 10.13 shows the nature of this mode of stuckpipe. There are distinct signs that can alert a driller of upcoming ledge-induced pipe sticking problems. They are: (i) hard and soft streak formations are drilled. There is sudden change in ROP; (ii) mud logging samples show soft and hard rocks; (iii) there is potential for fractured formations to be drilled; (iv) erratic over pull is observed; and (v) it can happen while tripping or drilling and it is also related to micro doglegs.

There are a number of ways to free a mechanically stuck pipe. They are already discussed in a previous chapter and therefore wouldn't be repeated here, except for the following summary of various procedures:

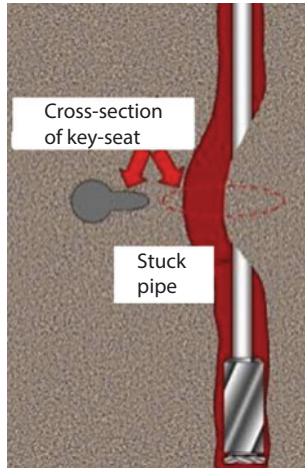

Figure 10.12 Mechanical pipe sticking.

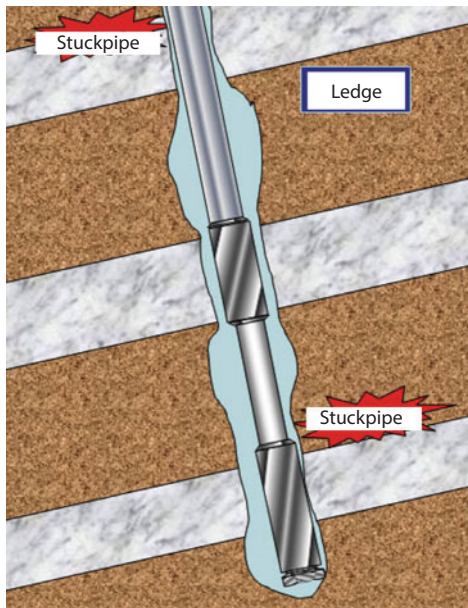

Figure 10.13 Ledge-induced pipe sticking.

1. If cuttings accumulation or hole sloughing is the suspected cause, then circulate a high viscosity and low filtrate mud. Rotate and reciprocate the drillstring and increasing flow rate without exceeding the maximum allowed equivalent circulating density (ECD).

2. If hole narrowing as a result of plastic shale is the cause, then an increase in mud weight may release the pipe. If circulation is not possible, attempt to restore with maximum pressure. If necessary, pressure up the annulus to push back shales.
3. If hole narrowing as a result of salt is the cause, then circulating fresh water can free the pipe.
4. If the pipe is stuck in a key-seat area, the drillstem must not be pulled sharply. Instead, try moving down with torque. Jar down. Spot a highly lubricating slog. If unsuccessful, back off as close to the stuck point as possible. Run in while in with jarring outside diameter small enough to enter the key seat on running in. If 2 to 3 hours of jarring is unsuccessful, spot lubricant and continue jarring.
  - If sticking occurred while moving up, apply torque and jar, down with maximum trip load.
  - Stop or reduce circulation when cocking the jar and when jarring down.
  - Continue jarring until the string is free or alternative decision is made.
  - Spot acid if stuck in limestone or chalk. Place fresh water with mobile salt.
  - When the string is free, increase circulation to maximum rate, rotate and work the string. Ream and backream the hole section thoroughly. Circulate the hole clean.

### 10.1.5 Horizontal Drilling

Every horizontal well drilling involves drilling of a vertical segment. After the establishment of the vertical segment of the well, the horizontal drilling process involves three main tasks:

1. Establishing the desired azimuth direction while the drill-pipe is still in the vertical direction.
2. Building the radical section of the well using steering mode of operation.
3. Building the horizontal section of the well with using rotary mode of operation.

Horizontal drilling processes in the oil industry utilize directional MWD instruments to monitor the position and the orientation of the bottomhole assembly (BHA). As such, the horizontal drilling system should include directional measurement-while-drilling (MWD) equipment and

a steerable system in addition to the conventional drilling assembly. The present directional monitoring equipment includes three accelerometers and three magnetometers mounted in three mutually orthogonal directions. At some predetermined surveying stations, the accelerometers measure the Earth's gravity components to determine the BHA inclination and tool face angles while the magnetometers measure the Earth's magnetic field to determine the BHA azimuth. As discussed in earlier sections, these measurements form the most crucial aspect of horizontal well drilling.

The drilling assembly for the horizontal drilling process consists of a diamond bit, a high speed motor with a bent housing, a mule-shoe orienting sub with built-in float valve, non-magnetic drill collars which include magnetic surveying tools, and a slick drill pipe (Figure 10.14).

The nonmagnetic drill collars carry the surveying equipment, and stabilize the movement of the motor. They are usually designed from monel metal to avoid external interference to the magnetic surveying tools. Horizontal well technology involves drilling a vertical hole (usually using conventional rotary drilling) to an appropriate depth. The horizontal drilling equipment is then installed with the bent housing adjusted to an appropriate offset angle (usually less than 3 degrees). The assembly is installed down the hole and rotated so that the offset points toward the desired azimuth direction. Subsequently, a window is cut through the casing using a special bit, and the "kick off" continues from that point on with the ongoing azimuth angle being monitored using three-axis magnetometers. The inclination (the deviation from the vertical direction) and the tool face angle are determined using three-axis accelerometers.

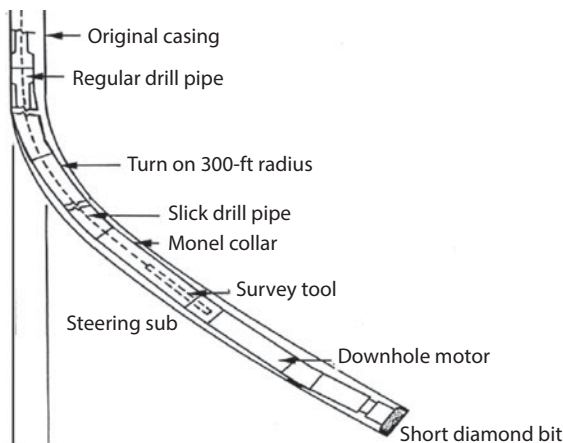

**Figure 10.14** Horizontal drilling assembly (From Nouredin, 2002).

The productivity of a horizontal well depends on the well length. This has prompted the petroleum industry to push for very long horizontal wells, as long as a kilometer as early as 1980s. However, it has been recognized later that horizontal wells do pass through an optimum, particularly for heavy oils that offer significant resistance to flow hereby nullifying the effects of the length of the well (Islam and Chakma, 1992). The horizontal drilling techniques are classified into four different categories based on the turning radius and the angle-building rate. The turning radius is the radius required to turn from the complete vertical to the complete horizontal directions. The angle build rate defines the deviation of the drill-pipe from the vertical direction per distance traveled. Table 10.1 shows the drilling categories with their turning radii and penetration rates. The category employed in such horizontal drilling process depends on the plans of the drilling contractors, the nature of the formation and the depth of the vertical hole.

In general, horizontal wells have several advantages over the conventional vertical ones. These advantages are well discussed by different researchers.

1. Horizontal wells have large contact area with oil or gas reservoirs. Therefore, for a fixed delivery rate, the pressure draw-down required in horizontal wells is much smaller when compared to vertical wells.
2. Horizontal wells provide high deliverability if compared to conventional vertical wells. The horizontal well productivity is about 2 to 7 times that of the vertical well.
3. Due to its high deliverability, drilling horizontal wells can reduce the number of wells required and minimize surface disturbance, which is very important in environmentally sensitive areas.

**Table 10.1** The different horizontal drilling categories with the corresponding turning radii and build rates (From Joshi *et al.*, 1991).

Drilling category	Turning radius	Angle build rate
Ultra-short radius	1–2 ft	40°/ft–60°/ft
Short radius	20–40 ft	2°/ft–5°/ft
Medium radius	300–800 ft	6°/100 ft–20°/100 ft
Long radius	1000–3000 ft	2°/100 ft–6°/100 ft

These advantages, however, come with extraordinary challenges from the drilling aspect. In the following section, we review difficulties associated with horizontal well drilling.

### 10.1.5.1 Problems Associated with Horizontal Well Drilling

The majority of drillpipe failures are attributed to fatigue. Fatigue failure considers that the drilling hook at surface or drilling bit undergoes fluctuated weight ranging from 0 to 3000 kN, and rotational speeds ranging from 50 to 200 rpm. The rate of penetration of the drilling tools can vary from 1 to 50  $\text{m} \cdot \text{h}^{-1}$ , and torque applied to the drillstring at surface is ranging from 0.5 to 70 KN-m due to the borehole friction (Albdiry and Almensory, 2016). As shown in Figure 10.15, a high level of stress concentration in the thread roots connections and a high stress concentration at the upset transition area of the drill pipe are responsible for causing fatigue failure in the drilling tools. These are the sites that are the most strained during horizontal well drilling (Figure 10.16).

This scenario becomes more complex due to borehole eccentricity, which is unavoidable during drilling of petroleum formations. Decades ago Knight and Brennan (1999) concluded after an array of experimental tests that any stress concentration combined with a modest amount of the drill collar bore eccentricity can result in a notable reduction in the fatigue life of the drillpipe under bending loads (Figure 10.16). Yonggang *et al.* (2011)

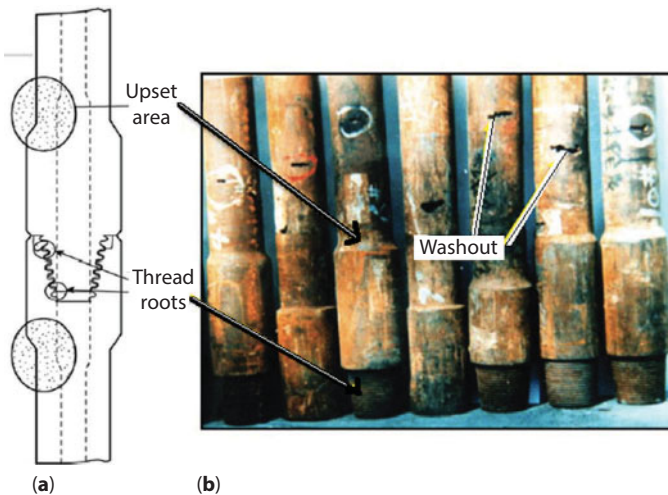

**Figure 10.15** (a) Critical regions of the drillpipe and connection causing fatigue failure; and (b) washout failure of the drillpipe transition.



simulated the stress state of the drillpipe transition zone position. As anticipated in Figure 10.16, they discovered that the transition zone is the weakest position of the whole drillpipe, and the length of transition zone and transition zone chamber radius  $R$  had a significant influence on the stress concentration. There are two types of fatigue loadings on the drillstring: doglegs that is reversed bending through borehole features, and a raft of sources collected under dynamic vibration. Doglegs are regions of the wellbore which have unavoidable deviations that can occur with drilling of horizontal wells where the drillpipe rotates in a curved segment as shown in Figure 10.16. The curved segments cause fully reversed alternating tension-compression stresses (cycles). Technically, that's the recipe for the most strenuous maneuvering of a tubular. In order to combat this phenomenon, the beveled shoulder threads (BST) in the horizontal directional drilling (HDD) technology is helpful. Zhu *et al.* (2013) demonstrated the suitability of BST for drillpipe threads design owing to a high bending strength, a large flexural rigidity and ability to withstand large bending loads.

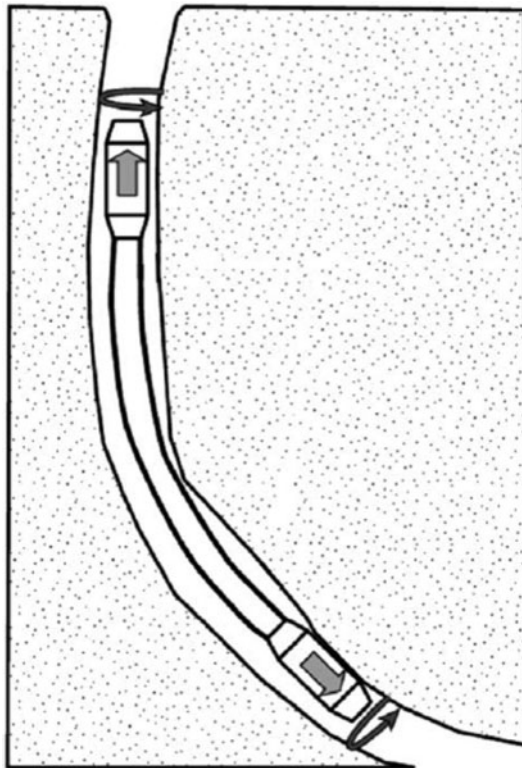

**Figure 10.16** Extraordinary stress during horizontal well drilling.

The effect of stress concentration on the pin and box threaded joint's failure of the upset drill pipes was investigated by Luo and Wu (2013) under the combined tensile and bending loads. They determined that tool failure is caused by the maximum stress concentration and fatigue crack nucleated at the first root of the tooth from the pin tool joint shoulder of the drillpipe, and then propagated through the wall of the tool joint. The deterioration of the fatigue resistance of the tool joint is related to the dogleg region where severe cyclic bending load exists due to the local deviation of the drillpipe from the vertical line.

The applied heavy and complex dynamic loadings on the drillstring caused by the rotation of the rotary top drive in the surface can produce different states of stresses with a turbulent movement in the downhole and consequently causing excessive vibrations. As stated earlier, such vibrations can trigger drilling failures. This vibration is a to and fro movement or it is the manifestation of the oscillatory behavior in the drillstring. The application of drilling aid methods such as air drilling may also exacerbate the drillstring vibration due to the damping effect of the drilling fluid. The fluid system as well as the rock mechanics are different in horizontal wells from vertical wells. During horizontal well drilling, all three of axial, torsional and lateral vibrations combine, resulting in unwanted vibration modes of the drillstring and inefficient drilling. Hence, it is essentially operating the drillstring above or below the critical speed. Often, this combination of torsional vibrations coupled nonlinear axial-transverse vibrations and lateral instabilities result in damaging the drilling tool and damaging the entire drillstring. Kapitaniak *et al.* (2015) conducted the effect of complex drillstring vibrations and the role of stick-slip oscillations, whirling, drill-bit bounce and helical buckling of the drillstring on the drilling rig conditions.

In the oil and gas drilling industry, analysis of the drillpipe buckling load has been a challenge since the buckling load can increase the bending stress and over time lead to fatigue failure of the drillpipe. Most of the analytical, numerical and experimental studies conducted on the buckling failure in different wellbore geometries such as vertical, inclined, and curved are reviewed by Mehdi Hajianmaleki (2014). The effects of torque, friction, flow rate, and tool joints on the sinusoidal and helical critical buckling loads are presented by Sun *et al.* (2015). They noted that in inclined wellbores, the drillstring first changes into a sinusoidal buckling shape and then changes to a helical buckling. Sun. *et al.* (2015) analyzed the nonlinear static post-buckling deformation, critical dynamic buckling load, and two different kinds of quasi-periodic motions i.e., the pipe moves up and down around its static buckling configuration or the pipe moves from one

side of the wellbore to the other side of a rotating drillstring constrained in a horizontal well. The theoretical calculations of the buckling loads and the right selection of the bottomhole assembly components were found to be useful for the practical design applications of the rotational drillpipe at high speeds and at small or large oscillation amplitudes.

As discussed in previous chapters, washout and twist-off are common failure modes encountered at the drillpipes. These failures are considered mostly to be due to mechanical fatigue damage or corrosion (Moradi and Ranjbar, 2009). Corrosion in the drillpipe is the sort of deterioration that happened due to the reaction between the pipe and the environment. The corrosion mechanisms in the drillpipes are either electrochemical corrosion or corrosion by mechanical action or by a combined effect of the mechanical and the corrosive agents. It turns out that the drillstem in horizontal wellbores is the most vulnerable due to greater level of surface area and high level of fatigue.

The washout as a non-critical failure can be defined as a leak, crack or a small opening in the drillpipe (Knight and Brennan, 2003). The washout is relatively a more common failure while the twist-off failure is less frequent; that is a severe and very expensive failure. Based on the collected database from previous studies conducted on the failure of the drillstring, it was revealed that around 95% of the drillpipes failed by washout near the bottomhole assembly and the rest failed by the twist-off (Mehdi Hajianmaleki, 2014). Of these failures, 65% belonged to the slips area, and 22% occurred in the drill collars. Moreover, another operational factor is capable to generate a stress concentration and lead to a complete fracture, that is die-marks which is produced from slip and tongs.

#### *10.1.5.2 Unique Problems Related to Horizontal Well Drilling*

There are a number of parameters that are unique to horizontal well drilling. They are:

1. **Torque and Drag:** Drag is a force restricting the movement of the drill tools in directions parallel to the well path. Torque is the force resisting rotation movement. Similar to the directional section of the well, horizontal wells pose unique constraints on the drilling process because the horizontal section is in an orthogonal position vis à vis the vertical section. Reducing drillstring weight reduces drag and torque at high quality of mud with appropriate chemical and

physical properties that are essential. Oil-based mud should be considered for more demanding situation because of its extra lubricating qualities.

2. **Hole Cleaning:** A particular problem that arises in drilling horizontal wells is the difficulty of removing the rock cuttings from the horizontal section of the well. The source of the problem is that cuttings tend to settle in the bottom of the hole and allow mud to pass above without transporting them. During the transition from the vertical to horizontal section in the drillpipe and from horizontal to vertical section in the annulus, debris/cavings are susceptible to accumulating behind the BHA. High fluid velocities and polymer muds are commonly used for efficient hole cleaning and minimizing formation damage. Even then, the design of a mud system is affected for applications of the horizontal well drilling. Furthermore, oil-based muds can control shale swelling. This is important in cases in which borehole traverses through a shaley formation. Of course, it is also advisable to increase salt content that can result in reducing chemical activities of shales.
3. **Directional Control:** Overcoming the force of gravity is a fundamental problem in directional and horizontal drilling. The BHA includes bits, motor, nonmagnetic drill collar and MWD tool. The BHA section controls the hole trajectory but does not contribute to WOB. Therefore, this section should be kept as lightweight as possible to minimize torque and drag.
4. **Anisotropy:** Anisotropy affects horizontal wells different from vertical wells. As we'll see in the next section under case studies, drilling horizontal wells along the maximum horizontal stress is quite different from along the minimum horizontal stress direction.

## 10.2 Case Studies

### 10.2.1 Drilling of Multilateral and Horizontal Wells

The following section discusses the drilling of multilateral and horizontal wells in a complex reservoir with high anisotropy in Saudi Arabia.

### 10.2.1.1 Introduction

Khan and Al-Anazi (2016) reported a series of field cases of horizontal and multilateral drilling activities in Saudi Arabia. They suggested that excessive borehole breakouts and a faster rate of penetration (ROP) are the key contributing factors to the observed drilling challenges. As expected, they reported on many occurrences of pipe sticking due to differential sticking that were particularly intense in high porosity and/or depleted zones. As a result, determining the optimum mud weight for a given well based on a pre-drill geomechanics model was recommended to manage the hole stability. Furthermore, a safe limit for the ROP, set as a function of hole azimuth, was identified to manage efficient hole cleaning and avoid stuck pipe issues due to pack off. The recommendations made based on this analysis enabled successful drilling and timely completion of several horizontal wells across the field.

As part of an extensive program to expand a carbonate gas reservoir, Saudi Aramco embarked on drilling many horizontal and multilateral wells. As discussed by Rahim *et al.* (2012), the original design was to drill the wells along the minimum horizontal stress ( $S_{Hmin}$ ) direction, thereby maximizing production through transverse hydraulic fractures that would be part of a massive fracturing project.

The challenges of these drilling projects are due to: (i) the larger stress contrast across the wellbore resulting from the overburden ( $S_v$ ); and (ii) difficulties with drilling in the maximum horizontal stress ( $S_{Hmax}$ ) direction under the prevailing strike slip stress conditions in the field.

### 10.2.1.2 The Problem: Description and Solutions

Saudi Aramco has been successfully exploiting its gas reservoirs for the past two decades with hydraulically fractured vertical and horizontal wells. Many horizontal wells have been drilled in this relatively tight carbonate formations that are often fractured but can use hydraulic fracturing for a boost in production (Rahim *et al.*, 2012). During the planning phase, several data sets, including open hole logs from neighbouring sites, were integrated through geomechanical analyses in order to develop the so-called mechanical earth model (MEM) providing magnitudes of the three principal in-situ stresses, the azimuth of  $S_{Hmax}$  direction, pore pressure and the rock strength properties along the logged open hole section. The MEM offered a solution that horizontal wells drilled toward the minimum horizontal stress ( $S_{Hmin}$ ) offer a better chance of higher production from fracturing. In that case, hydraulic fractures induced in a wellbore parallel to  $S_{Hmin}$  will be orthogonal to the wellbore, thereby ensuring better reservoir contact with the formation and providing the possibility of inducing many

fractures without compromising fracturing efficiency. It turned out that horizontal wells drilled along the  $S_{Hmin}$  created numerous drilling-related problems. Because the wellbore is subject to higher stresses and thereby requires greater mudweight to control breakdown or collapse of the formation, using the previous mud program created mud-related drilling problems, including borehole instability. A pilot program to drill along  $S_{Hmin}$  has already yielded positive results when mud weight was adjusted.

In the process of constructing the MEM, the identification and analysis of the drilling events related to geomechanics in the offset wells provide good calibration and validation data to make a first pass determination of the in-situ stress direction and magnitude and thereby help constraining the MEM. Subsequently, as the well is drilled in the target reservoir, dynamic calibration and updates of the model are performed along with predictive mud weights with the help of real-time logging information.

Figure 10.17 and 10.18 show the events logs for Wells X-1 and X-2. Two example wells are cited in this section. The time-dependent wellbore instability occurring across the argillaceous intervals in the pre-Khuff Unayzah formation is observed in Well X-2. In Well X-1, the stuck pipe event leading to sidetrack is most likely related to the drilling break. In the sidetracked hole (Well X-1), all the wellbore instability events in the Unayzah formation occurred after freeing the stuck pipe on 12/22. Relevant information was then used to perform a history match to validate the MEMs.

The MW windows shown in Figures 10.19 and 10.20 indicate mud weight limits for which either mud kick or mud loss can occur. Mud kick

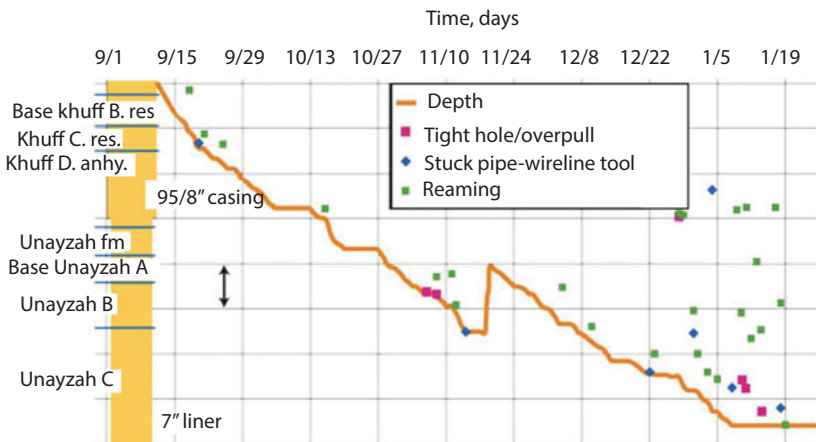

Figure 10.17 Events log for Well X-1 (Rahim *et al.*, 2012).

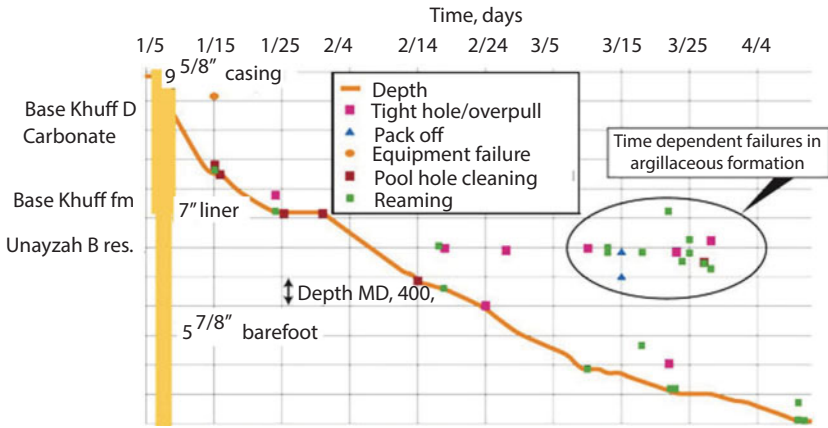

Figure 10.18 Events for Well X-2 (Rahim *et al.*, 2012).

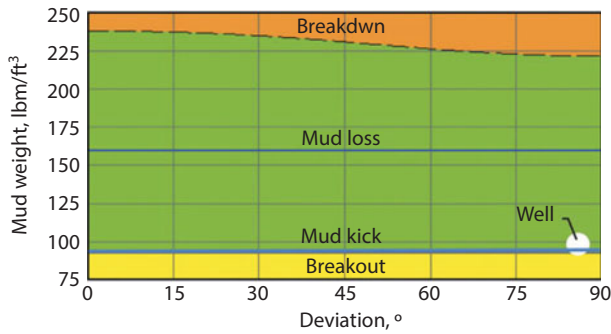

Figure 10.19 Mud weight vs. well deviation.

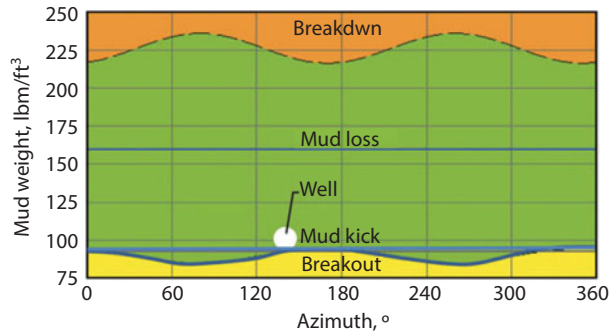

Figure 10.20 Mud weight vs. well azimuth.

occurs as borehole fluid pressure falls below reservoir pressure and mud loss occurs when borehole fluid pressure exceeds reservoir pressure. Both these situations should be avoided for wellbore stability. Of course, these graphs are simulation results out of the MEM that is continuously updated as new data set becomes available. Initial modeling can be performed with nearby well data, based on the drilling experience for the given mud weight, in-situ stresses, formation pressure, and the rock strength. The predicted borehole condition is compared with actual downhole measurements (caliper and image log when available) and the drilling events to ensure that all parameters included in the model are constrained and capable of predicting the downhole conditions with reasonable accuracy. The calibrated model is then utilized to conduct stimulation design, predict MWs during drilling for planned vertical and deviated wells, or perform other analyses.

The MEM for Well X-3 spans the interval from kickoff to the total depth (TD), which covers the Base Khuff formation and Unayzah-A reservoir. The MEM developed for the planned Well X-3 was calibrated using Well X-1 data, both wells were drilled in the same  $S_{Hmin}$  direction. A MEM was used in real-time while drilling Well X-3. A minimum safe MW of 91 lb cu ft (pcf) was recommended to drill the planned Well X-3 to minimize drilling problems due to wellbore instability. The well was successfully drilled with a MW of 92–93 pcf (Figure 10.21).

The problems encountered and lost time are shown in Figure 10.21. Well X-1 has been a difficult well as a very small safe MW window was predicted. The well shows numerous breakout points in the reservoir section. The caliper log indicated a large impact in the wellbore diameter and shows significantly large bore size compared to bit size of 8½ in.

A comparison of Figures 10.21 and 10.22 with Figure 10.17 shows the decrease in drilling events, thereby reducing the NPT. This decrease in drilling events can be attributed to the effort invested in planning, constructing, and calibrating the MEM and using the recommended MWs while drilling.

The drilling of Well X3 encountered very little difficulty as compared to Well X1, with insignificant breakouts and borehole size matching the bit size, showing wellbore integrity.

Following the same work flow, another program for Well X-4 was developed. Table 10.2 shows the recommended mud weight plans. As shown in Figure 10.22, Well X4 was drilled with 100 lbm/cuft (pcf) in the Sudair formation. However, the mud weight had to be increased to 103 pcf to suppress water flow (Table 10.2). The intermediate casing was set without any problem. The reservoir section was drilled successfully in the Khuff formation with a mud weight of 85 pcf.



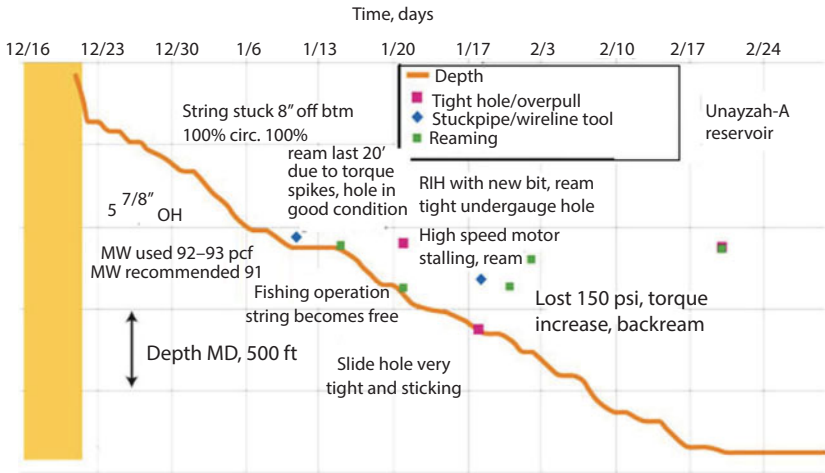

Figure 10.21 Event and activity log of Well X3 (Rahim *et al.*, 2012).

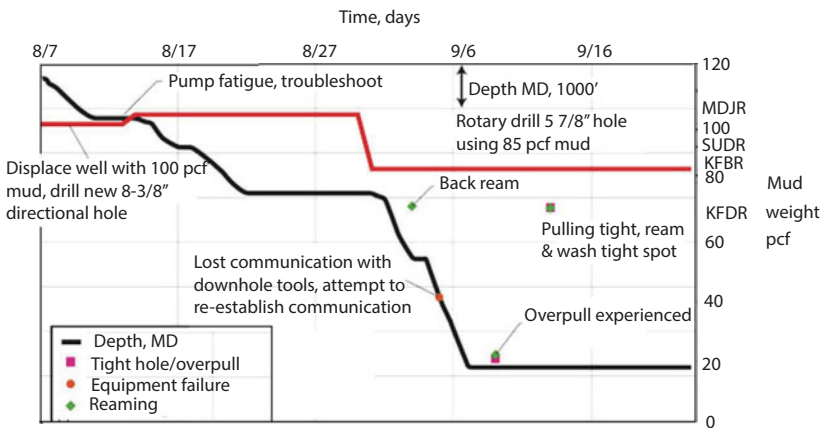

Figure 10.22 Event and activity log of Well X4 (Rahim *et al.*, 2012).

### 10.2.1.3 Broader Picture

The failure data were collected and later calibrated with observed well failures, leading to the construction of profiles of stress magnitudes along the well trajectory, as shown in Figure 10.23. The magnitude of horizontal stresses are affected by the rock elastic properties and pore pressure, Contrasting rock porosity and mineralogy can cause contrast between the  $S_v$  and the two horizontal stresses in different layers. While traversing such layers, a horizontal well drilled in the  $S_{Hmin}$  direction,  $S_v$  and  $S_{Hmax}$  will face

**Table 10.2** Recommended mud weight planned for well X-4.

Formation	Recommended mud weight (lb/cu ft)	Mud weight used during drilling (lb/cu ft)
SUDR	100	100–103*
KHFF, KFAC	89	103**
KFBC	87	85

\*Mud weight was increased to 103.0 lb/cu ft due to water flow in SUDR formation

\*\*7” liner

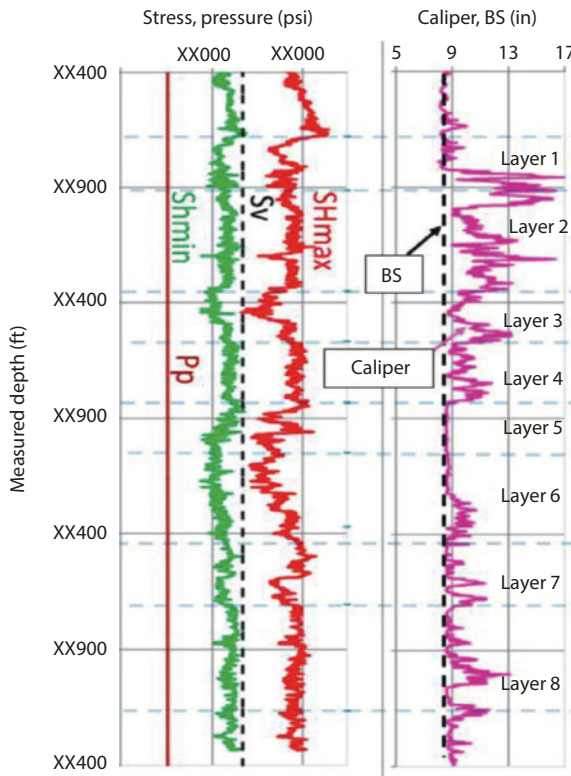

**Figure 10.23** In-situ stresses and pore pressure profile based on the observed hole condition for a well drilled along the  $S_{Hmin}$  direction.

higher stress concentrations (compressive) at the top and bottom of the wellbore wall. Across some zones along the wellbore, when this concentrated stress magnitude is higher than the value of the effective mud support, the wellbore wall can fail and develop breakouts of variable severity,

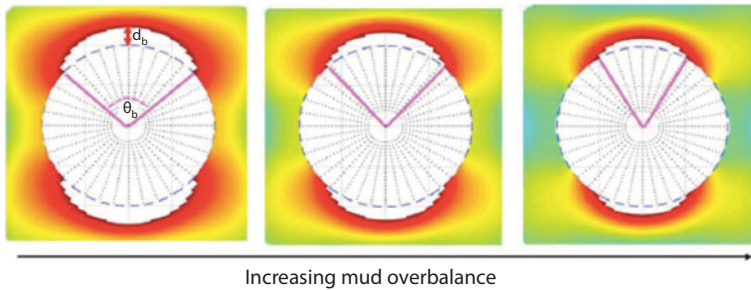

**Figure 10.24** Effect of mud overbalance on calculated breakout severity at a given depth.

as indicated by caliper data, as can be seen from Figure 10.23. The severity of drilling constraints, such as tight hole, overpull, high torque and drag, pack off and stuck pipe is alleviated with increasing mud overbalance.

At the same time, the identification and analysis of the drilling events related to geomechanics in the offset wells provide good calibration and validation data to make a first pass determination of the in-situ stress direction and magnitude and thereby help constrain the MEM. Subsequently, as the well is drilled in the target reservoir, dynamic calibration and updates of the model are performed along with predictive MWs with the help of real-time logging information.

An optimum overbalance condition is sought under these conditions. As seen in Chapter 9, mud overbalance is vastly dependent on geomechanical conditions and too high a density can create other complications.

As shown in Figure 10.24, an optimal overbalance will stabilize the wellbore wall and minimize the breakout severity while maintained below the threshold of differential sticking problems. Figure 10.24 shows the extent of the white region outside the blue dotted circle (bit size) that represents breakout severity. Higher mud overbalance stabilizes the wellbore wall and reduces breakout width ( $d_q$ ) and depth ( $d_b$ ). It is a matter of choosing an operating condition that would allow moderate breakouts while assuring safe operating conditions to avoid differential sticking. Also important is the rate of penetration (ROP), which has clear bearing on the drilling operation. The ROP must also be optimized as a low ROP can lead to accumulation of cuttings, which would make a horizontal well vulnerable to plugging, caving, and other problems.

Figure 10.25 shows the drilling experience data from several horizontal wells with each data point representing a well with an azimuth, as represented through radial lines, varying between  $0^\circ$ , or parallel to the  $S_{Hmax}$  direction, and  $90^\circ$ , or parallel to the  $S_{Hmin}$  direction in the reservoir. The

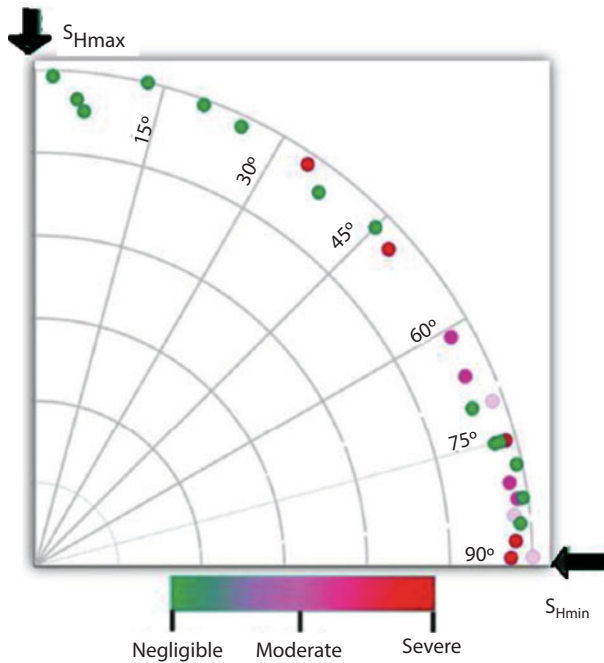

**Figure 10.25** Drilling experience in horizontal wells drilled in different directions.

concentric circles represent the well deviation – 0° being a vertical well and the outermost circle being a horizontal well. The color of the data point symbolizes the severity of the drilling problems encountered, where red indicates that the well could not be drilled according to the plan due to severe and repeated drilling problems, while green indicates that the well was drilled according to plan without any significant drilling problem. Similarly, the pink and light pink colors represent moderate and minor drilling problems, respectively – i.e., tight hole, reaming, high torque and drag, etc. Although most of the wells were drilled as per plans, a few could not be completed to the desired depth due to drilling problems. It can be seen that as the well azimuth falls close to the  $S_{Hmin}$  direction, the drilling operations became more challenging. A series of data were analyzed with an attempt to discover the cause of the drilling problems.

The data analysis indicates that the majority of stuck pipe events are associated with back reaming and pulling out of hole. These problems may be attributed to the cuttings and cavings settled at the bottom of the hole. This problem can be alleviated with mud overbalance. In addition, another factor needed to be considered. During the tripping out or back reaming

operations, if upward movement of the drillstring is faster than the rate at which the rock debris can be circulated out, the cuttings/cavings will accumulate behind the bottomhole assembly (BHA) and may cause tight hole or stuck pipe at some depth above the current well depth.

The wells were ranked based on the severity of the drilling problems observed, and the corresponding mud overbalance, Figure 10.26a, and average ROP, Figure 10.26b, are plotted as a function of hole azimuth from the  $S_{Hmax}$  direction. The color of the data points represents the severity of drilling problems. The data shown belongs to wells drilled in two adjacent fields, Field 1 (F1) and Field 2 (F2), targeting two reservoir zones vertically separated by a nonproducing thick layer. The alphanumeric data labels in Figure 10.26a indicate the well number (number at left) and the field, either F1 or F2. Figure 10.26a indicates that wells with an azimuth up to  $45^\circ$  from the  $S_{Hmax}$  direction can be drilled with the same overbalance of 10 pcf to

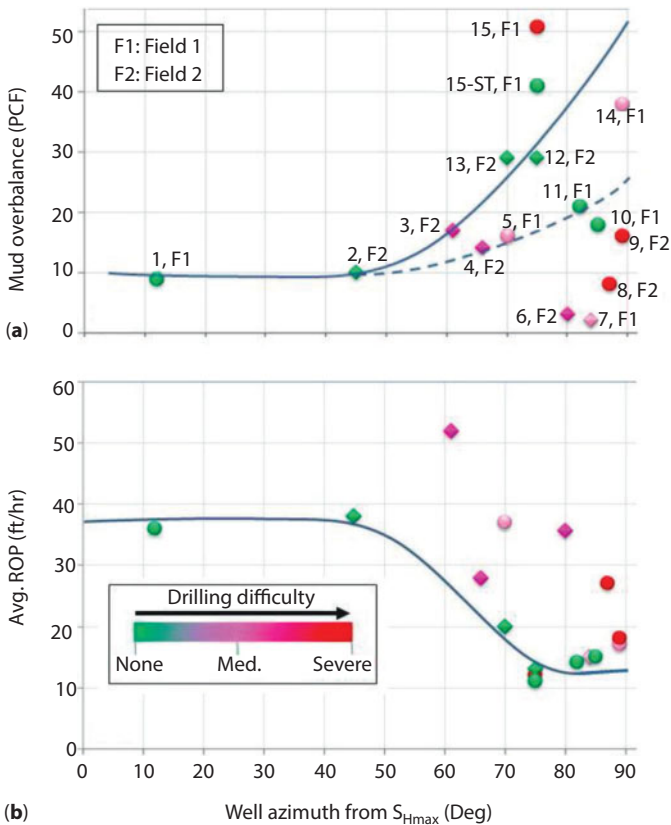

Figure 10.26 Mud well azimuth vs. (a) Mud overbalance; (b) Average ROP.

12 pcf in both fields and with a ROP between 35 ft/hr to 38 ft/hr. When the well azimuth from the  $S_{Hmax}$  direction increases above  $45^\circ$  – the well gets closer to the  $S_{Hmin}$  direction – the mud overbalance needs to be increased as per the two curves in Figure 10.26a for the two fields, solid curve for F1 and dotted line for F2, to maintain the wellbore stability. The variable mud overbalance requirements for the two fields suggest that in-situ stress conditions and other geomechanical factors may be different for the and recommendations were for known in-situ stresses and rock strength properties. The extent of the white region outside the blue dotted circle (bit size) represents breakout severity. Higher mud overbalance stabilizes the wellbore wall and reduces breakout width and depth.

The well data presented in Figure 10.26 were used to further classify the wellbore stability based on the ROP values and the mud overbalance, grouping them into four risk categories, as shown in Table 10.3. Wells falling into risk category 1 are those where both the ROP and the mud overbalance are within the safe limits defined per Figure 10.26; these wells were drilled without any major drilling problems – Wells 1, 2, 10, 12 and 13. Risk category 2 includes those wells where either the mud overbalance is below the stable

**Table 10.3** Ranking of wells based on severity<sup>1</sup>.

Well #	Mud overbalance	ROP	Stability indicator	Risk category color code
1	Ok	Ok	Stable	1/Green
2	Ok	Ok	Stable	1/Green
3	Ok	>>	Poor hole cleaning	2/Pink
4	<	>	Breakouts	3/pink
5	Ok	>	Poor hole cleaning	2/Purple
6	<<	Ok	Breakouts	2/Pink
7	<	Ok	Breakouts	2/Purple
8	<	>	Breakouts, Poor hole cleaning	3/Red
9	<	>	Breakouts, Poor hole cleaning	3/Red
10	Ok	Ok	Stable	1/Green
12	Ok	Ok	Stable	1/Green
13	Ok	Ok	Stable	1/Green
14	>>	Ok	Differential sticking	4/Purple
15	>>	Ok	Differential sticking	4/Red

<sup>1</sup>Ok: Parameters within the safe limits defined by trend lines in Figure 10.26

limit, resulting in breakout development, Wells 6 and 7, or the ROP is above the safe limit, causing a higher rate of cuttings generation, Wells 3 and 5. Such wells are ranked as medium risk and can experience drilling problems such as tight hole, high torque and drag, and occasional stuck pipe issues.

Likewise, if both parameters are exceeded – the mud overbalance is low and the ROP is above the safe limit – there is a higher risk of getting stuck and experiencing a loss of tool and BHA as excess cuttings and cavings generated downhole may be difficult to circulate out effectively. These wells are classified as high risk and fall under risk Category 3, Wells 4, 8 and 9. Wells falling into risk Category 2 would require adjustment in one of the two parameters to achieve stable wellbore condition. For risk Category 3 wells, a simultaneous increase of mud overbalance and reduction in ROP to the safe limit are required to maintain wellbore stability. Extremely high risk wells are those included in risk Category 4, where mud overbalance is significantly above the stable limit for managing breakouts – stable wellbore – even as ROP is within the safe limit. Such wells, Wells 14 and 15, encountered stuck pipe problems due to differential sticking across the permeable zones. The solution to this problem is to reduce the mud overbalance and bring it close to the stable mud weight overbalance limit,

#### 10.2.1.4 Lessons Learned

This detailed case study offers a number of lessons involving horizontal well drilling. Figure 10.27 shows how corrective measures have improved the drilling operations. As outlined in the introduction section, the biggest challenge of this project in question was to be able to drill along  $S_{Hmin}$ . Previously the drilling was along  $S_{Hmax}$  but needed to change in order to optimize hydraulic fracturing operations. The wellbore integrity and

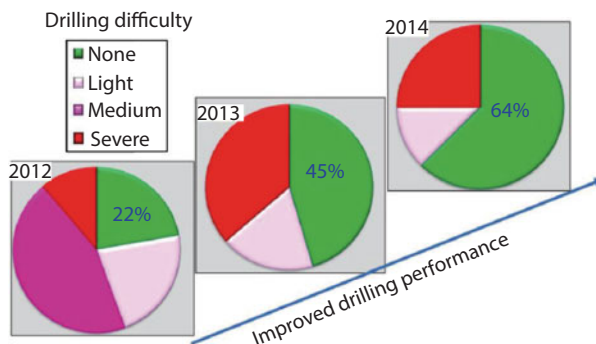

Figure 10.27 Improvement of drilling operations over time.

stability is a legitimate concern while drilling a well in the  $S_{H_{\min}}$  direction. This is because stresses on the openhole section are increased, and breakouts and breakdowns can happen more frequently.

Figure 10.27 shows that the number of successful wells increased from 22% in 2012 to 65% in 2014. In about 25% of the wells in 2014 that experienced severe drilling problems, the problems were mainly differential in nature, viz., drilling through more depleted and/or high porosity zones.

By using the earth mechanical model and upgrading information in real time, the drilling program was continuously improved. The key parameters were ROP and mud overbalance, while the unchangeable parameter was the azimuth.

Horizontal wells oriented up to  $45^\circ$  from the  $S_{H_{\max}}$  direction can be drilled safely with the same mud overbalance, i.e., 10 pcf to 12 pcf, in both fields studied. For well azimuths above  $45^\circ$ , horizontal wells drilled in Field 1 require a lower mud overbalance to achieve main hole stability compared to Field 2.

Mud program was different for drilling toward the  $S_{H_{\min}}$  direction, for which a mud weight overbalance of 45 pcf to 50 pcf was required in Field 2, while a mud overbalance of 15 pcf to 20 pcf was required for Field 1. This result highlights the need to investigate anisotropy in as much detail as possible, the lack of which can have a catastrophic outcome.

In terms of ROP, a sustained ROP between 10 ft/hr and 20 ft/hr was optimum for proper hole cleaning as well as wellbore integrity. More significantly, the ROP in the study wells was found to vary in the range of 20 ft/hr to 50 ft/hr. For wells experiencing the same breakout severity, those drilled using a  $5\frac{7}{8}$ " bit had an extra burden on achieving hole cleaning efficiency because of the reduced annular area, ranging from 55% to 75%, as compared to that from an  $8\frac{3}{8}$ " bit. Both ROP and proper mud overbalance are key to manage hole cleaning efficiency.

Most of the drilling problems, i.e., tight hole and stuck pipe, are reported while pulling out of hole and/or back reaming to make the connection. Clearly debris/cavings accumulated behind the BHA cause restrictions. Tripping operations must be carefully designed for horizontal well cases as the nature of debris detachment is different from the vertical well scenario.

Overall, the combination of pre-drill geomechanic studies based on offset well data, real-time geomechanics support of field operations and post-drill analysis of actual drilling experience helped overcome drilling problems.

### 10.2.2 Directional Drilling Challenges in Deepwater Subsalt

Cromb *et al.* (2001) reported a case study of two directional wells in deepwater subsalt formation of the Gulf of Mexico. Subsalt reservoir



development is a major challenge for oil companies from the standpoint of seismic interpretation and drilling operations. Formed over time by evaporating seawater, salt formations can accumulate to thicknesses of several thousand ft. Because salt is both ductile and impermeable, it can effectively trap oil and gas. While salt retains its low density after burial, surrounding sediments tend to compact and become increasingly dense with depth. The resulting density and pressure variations can present difficult circumstances that drillers must overcome. Further, its high seismic wave velocity – about twice that of surrounding sediments – complicates seismic processing and interpretation.

Reservoir information was quite limited for this case and directional drilling offered great challenges of the following form:

1. Kicking off a well without a riser in large-diameter hole
2. Controlling wellbore trajectory through more than 3,000 ft of salt
3. Executing difficult sidetracks to revised bottomhole targets

During the 1980s, seismic processing began to image more correctly the salt structures under which hydrocarbons could accumulate. Over the last five years, further advancements in seismic acquisition, processing and interpretation techniques have enabled the nuances of salt structures to become visible, more accurately imaging not only the top of the salt but its bottom and adjacent sediments, as well. However, the salt still presents limitations.

Allocthonous salts are believed to have migrated horizontally after reaching vertical equilibrium in their original locations. In the Gulf of Mexico, these geologic phenomena occur mainly in deepwater, where sediments are not as thick as the near-shore continental shelf. Numerous economic hydrocarbon deposits have been discovered underlying these salt formations, including the Gemini field.

#### *10.2.2.1 Description of the Reservoir*

Discovered in 1995, the Gemini field is located in Mississippi Canyon Block 292 of the Gulf of Mexico, in 3,400 ft water depths. The field is a joint development project between Texaco (60%) and Chevron (40%). The No. 1 exploratory well tested the 11,300-ft true vertical depth (TVD) target interval, the Allison sand, at a rate of 32 MMcfd natural gas and 627 b/d condensate.

Upon this discovery, two additional wells (No. 3 and No. 4) were planned that included appraisal drilling not only for Allison sands, but also

for deeper targets, the Dean and Erin sands at about 15,000 ft. All three wells would produce from a collective subsea system into a pipeline that was tied back to a neighboring platform.

It was initially desired to have water-based mud in order to improve data acquisition abilities. However, hole stability would be a concern when using such a system. Consequently, The team developed a contingency plan to switch to an oil-based drilling fluid if similar problems were encountered.

#### 10.2.2.2 *Planning of Drilling*

The 7,000–10,000-ft depth of the salt formation featured prominently in a design of the drilling plan. At these depths, a drillable wellbore trajectory that allows kicking off below the salt to meet targeted objectives is impossible. Thus, the angle-build had to be completed before entering the salt, requiring a relatively shallow kick-off depth with respect to the mud line at 3,476 ft. Moreover, an S-shaped directional well profile was needed because the deeper targets were directly below the Allison sand. The well plans specified the following casing requirements:

1. 36" conductor jetted 250 ft below the mudline
2. 20" surface casing
3. 16" casing set into the top of the salt
4. 11" casing string set just below the salt, casing it off prior to drilling the reservoir
5. 9 5/8" liner across the reservoir to accommodate the expected flow rates.

Since the No. 1 well had no shallow water flow, it was not expected in the subsequent wells. Therefore, plans called for the 24" intervals to be drilled without a riser. Building angle in the weak shallow formations dictated the use of low-angle (no more than 2°/100 ft) build-up rates. It also required a shallow kick-off point in the 24" section. While this is not typical practice in Gulf of Mexico deepwater operations, it has been applied successfully in many other areas. However, shallow kick-offs typically are executed at lower build-up rates. Therefore, plans included building angle at 1 degree/100 ft from the 24" kick-off point to the 20" casing depth, and continuing at 2°/100 ft through the 17" by 20" section until reaching the 16" casing depth point at the salt interface. Achieving planned build-up rate in the 24" hole section and dropping angle in the salt formation toward the target was key.

Whether the directional work could be achieved by simultaneously drilling and under reaming was brought into question. Drilling motor use

limited the team's options to drilling a pilot hole and then under reaming, or drilling with a bi-center or steerable reaming-while-drilling tool. Because the latter option would allow less directional control, the former option was selected to first drill and then underream at casing point.

A 14" hole was planned for the salt formation, where the drop-off for the S-shape profile would begin at 1.5 degrees/100 ft. The final S-shape well design was to reach maximum angle at the 16-in. casing shoe depth, the angle dropping back to vertical at the Allison sand target. The No. 3 and No. 4 wells were to be drilled to azimuths of 55.3 degrees northeast and 307.3 degrees northwest, respectively.

### 10.2.2.3 *Drilling Operations*

The No. 4 development well was spudded first in early February 1999, followed by No. 3 about one month later. For both wells, 36" conductor and 20" casing were batch-set to maximize operational efficiency. A 24" jetting bottomhole assembly (BHA) that included an MWD tool and a 9 5/8" mud motor with bend set to 1.5° was used to drill to kick-off depth. In both wells, the motor provided excellent directional response in the soft formations, which helped to limit hole angle loss while circulating off bottom and optimize drilling parameters for favorable and controlled build rates.

In well No. 4, a 16.8° angle was built by casing point at an average rate of penetration (ROP) of 47 ft/hr. Well No. 3 reached 13.7 degrees inclination at casing depth, at ROP (rate of penetration) averaging 54 ft/hr. Ninety hours were required for well No. 3, from tripping in with the 36" jetting assembly to the start of running the 20-in. casing, which is an improvement over the 104 hr required for the same procedures on well No. 4. This may have been due to batch drilling the section, applying fresh experience to the next well. The large-diameter (24-in.) kickoffs achieved planned build rates and exceeded expectations in terms of directional control, thus meeting the first major challenge of the project.

Once the 20-in. casing was set, a 17" pilot assembly was then used in well No. 4 with the same mud motor and bend setting in order to finish building the curve to 33.3° at a 2°/100 ft rate. The BHA performed well. Drilling progress was enhanced by limiting sliding to 22.1% until the top of the salt. The ROP averaged 55 ft/hr before drilling into the salt, dropping to 15–18 ft/hr after salt penetration.

As the formations above the salt consisted of mainly gumbo clays, a downhole annular pressure measurement in the MWD string was used to monitor cuttings loading by calculating equivalent circulation density (ECD) while drilling. This procedure reduced the risk of packing off and sticking the assembly in the clays.

A 14" steerable BHA using the same motor, but with the bend set to 1.15°, drilled the remaining 3,560-ft salt section while holding the 31.5-degree tangent to the drop point, and then dropping to vertical at 1.5°/100 ft, rotating 84.1% of the total footage drilled. Drop-off through the salt was achieved as planned, the angle being reduced to 2.4° at casing depth. The second directional drilling challenge had been met: drilling the salt in a single BHA run while maintaining trajectory control.

The same drilling equipment and methodologies used for drilling out from the 20" casing in well No. 4 were applied to well No. 3, which exhibited similar drilling performance but required more steering because of higher maximum angle. ROP was less than the No. 4 well, averaging 36 ft/hr before the salt, and then dropping to 17 ft/hr inside it. However, the under reaming procedure performed after reaching TD (total depth) was faster by about 5 ft/hr.

A bit change improved ROP significantly in No. 3's salt section. A milled tooth bit increased ROP to 35 ft/hr, compared to 25 ft/hr for the previous bit run and 28 ft/hr on well No. 4. After drilling a total of 2,813 ft in 87 hr, the bit was in good condition with its seals still effective. A low-speed, high-torque motor and 50 rpm to 70 rpm from surface indicated that the bit was turning about 160 rpm during the run.

Following the salt zone, a 10 5/8 in. by 12" reaming-while-drilling assembly with MWD/LWD tools and an 8-in. PDC (polycrystalline diamond compact) pilot bit drilled both wells to TD. Such an assembly has proven successful when steerable directional work is not required. It allows measurements to be made using 6" tools in the 8-in. pilot hole rather than the 12-in. open hole, which reduces annular mud volume.

Both wells were successful from a directional drilling aspect in that the targets were hit precisely. Unfortunately, the Allison target sand in the No. 4 well proved to be of poor quality. Additionally, hole problems in the No. 3 well associated with the water-based mud prohibited wireline logging, thus increasing reliance on LWD data. As a result, sidetracks were planned for both wells.

#### 10.2.2.4 *Planning the Sidetracks*

New targets to the northwest were planned for well No 3. by sidetracking below the 11" casing shoe, or at about 11,580 ft, with a 10 5/8-in. hole. Synthetic oil-based mud was selected to eliminate formation stability problems. The Allison sand remained the primary target, with continued drilling planned to appraise a Dean sand target about 1,000 ft to the west-northwest and then on to TD in the Erin sand. The new well path required a total turn of 130 degrees.

Well No. 4 required a new Allison target, which meant coming up the hole to get sufficient displacement. The new target was about 1,300 ft east and 500 ft north of the initial target. Geologic circumstances required opening a window in the 11-in. casing and sidetracking into the salt formation at a whipstock setting depth of 7,534 ft. This resulted in the drilling of about 3,000 ft of salt section and more complex directional work. The sidetrack was planned for a 10 5/8-in. pass through a 12-in. hole, turning through 70 degrees and setting a 9 5/8-in. liner below the salt.

Well No. 3 was reentered, and a slick assembly was run to displace to synthetic oil-based mud, drill the abandonment plugs and retainer, and dress off the open-hole cement plug to 11,580 ft for sidetracking. Using a gyroscope survey for orientation, a whipstock was set in the 11-in. casing to sidetrack out of a window at 11,231 ft. The window was milled using a conventional three-trip milling system, since a one-trip system was not available.

The sidetrack BHA consisted of a 12" steerable reaming-while-drilling tool with an 8-in. milled tooth pilot bit run on an 8-in. mud motor with bend set to 1.5 degrees. The BHA was used to build 5.5 degrees of angle while turning at the planned dogleg severity of 1.75 degrees/100 ft. This bit run averaged 32.5 ft/hr with a sliding percentage of 34.5%.

After running the 9 5/8-in. liner below the Allison target, a new BHA was made up consisting of an 8-in. PDC bit run on a 6-in. extended power motor with bend set to 1.15 degree. This BHA was used to drill the 8 1/2-in. tangent section to intersect the Dean and Erin sands, rotating 97% and averaging 46 ft/hr ROP. Largely because of the synthetic oil-based mud, drilling performance improved in the No. 3 sidetrack, with ROP averaging 39.7 ft/hr compared to 16.8 ft/hr for the original hole.

A one-trip milling system was available for the well No. 4 work, and proved to save time while the synthetic oil-based mud from the No. 3 sidetrack saved money. Moreover, MWD orientation set the whipstock and mill assemblies to 42 degrees right of high side, which eliminated the need for a gyroscope survey. While some problems were encountered during the No. 4 window milling operation, which required two trips to solve, one less day overall was required to complete the well No. 4 procedure, as compared to No. 3, which employed the three-trip system.

Using the same sidetrack BHA, motor and setting, the No. 4 sidetrack, which extended 2,689 ft from a depth of 7,584 ft, took 99 hr to complete. The directional objective was achieved with an 18.7% sliding percentage and a 27 ft/hr average ROP. The milled tooth bit was pulled in good condition, which demonstrated superior ROP in the salt and minimized orientation time and sliding problems for both wells.

Tangent drilling through the salt was conducted with the existing BHA and a PDC bit. Salt base was reached at 10,716 ft, after drilling through 3,182 ft of salt. The PDC bit made sliding more difficult compared to the milled tooth pilot bit, lowering ROP to 10 ft/hr compared to 20 ft/hr for the first bit run. ROP in the salt averaged 26 ft/hr, increasing to 50 ft/hr through the remaining sediments.

Completed in only 11 days, the No. 4 sidetrack demonstrated exceptional drilling success, accomplishing for the first time in salt a sidetrack from a casing window using a steerable reaming-while-drilling assembly. In addition to proving the feasibility of appraising subsalt reservoirs using an initial pilot hole, the sidetracking success surely opens future multilateral development possibilities in subsalt reservoirs.

#### 10.2.2.5 *Lessons Learned*

Two complete subsalt wells and two difficult sidetracks were drilled in only 165 days. Despite the S-shaped well profiles and demanding sidetrack turn requirements, nearly 27,000 feet of hole was drilled with a BHA rotating percentage of 80.1%, demonstrating excellent directional drilling efficiency.

### 10.3 Summary

This chapter considers challenges during the drilling of a horizontal or directional well. Even though most of the outcomes of drilling problems are similar in horizontal/directional drilling as vertical well drilling, the directional/horizontal cases offer unique perspectives that are more complex than those of vertical cases. Discussions in this chapter are limited to unique features of problems related to directional/horizontal drilling. A comprehensive case study is added in order to elucidate various salient features of horizontal/directional drilling.

### References

- Albdiry, M.T., Almensory, M.F., 2016, Failure analysis of drillstring in petroleum industry: A review, *Engineering Failure Analysis* 65 (2016) 74–85.
- Azar, J.J. *Drilling Problems and Solutions*, Petroleum Engineering Handbook, SPE International Publication 2015, pp. 433–454.
- Cromb, J., Pratten, C., Long, M., Walters, R.: “Deepwater Subsalt Development: Directional Drilling Challenges and Solutions,” SPE Paper No. 59197, IADC/SPE Drilling Conference, New Orleans, Louisiana, February, 2000.

- Cromb, J.R., Long, M., Pratten, C., 2001, DIRECTIONAL DRILLING: Meeting directional drilling challenges in deepwater subsalt, *Offshore*, Feb. 1.
- Farmer, P., Miller, D., Pieprzak, A., Rutledge, J., and Woods, R.: "Exploring the Subsalt," *Oilfield Review* (Spring 1996), 8, No. 1, 50.
- Ghasemloonia, A., Rideout, G., Butt, S., 2015, A review of drillstring vibration modeling and suppression methods, *J. Pet. Sci. Eng.* 131, 150–164.
- Gulyaev, V.I., Solovev, I.L. and Gorbunovich, I.V. Stability of drillstrings in ultra-deep wells: an integrated design model, *Int. Appl. Mech.* 45 (2009) 772–779.
- Hadavand, Z., 2015, Reduction of Wellbore Positional Uncertainty During Directional Drilling, Geomatic Engineering, University of Calgary.
- Harris, D., and Jur, T. Classical fatigue design techniques as a failure analysis tool, *J. Fail. Anal. Prev.* 9 (2009) 81–87.
- [https://books.google.kz/books?id=zM\\_rCAAQBAJ&pg=PA172&lpg=PA172&dq=Directional++Drilling+Problems&source=bl&ots=BBTyA8Oiau&sig=w2Nm2GqRyaTufLOGuxpOBuxxZjU&hl=en&sa=X&ved=0ahUKewi667zd09bYAhWjDZoKHSY5C6cQ6AEIVjAH#v=onepage&q=Directional%20%20Drilling%20Problems&f=false](https://books.google.kz/books?id=zM_rCAAQBAJ&pg=PA172&lpg=PA172&dq=Directional++Drilling+Problems&source=bl&ots=BBTyA8Oiau&sig=w2Nm2GqRyaTufLOGuxpOBuxxZjU&hl=en&sa=X&ved=0ahUKewi667zd09bYAhWjDZoKHSY5C6cQ6AEIVjAH#v=onepage&q=Directional%20%20Drilling%20Problems&f=false)
- Inglis, T.A., 1987, *Directional Drilling*, London: Graham & Trotman Ltd.
- Islam, M.R. and Chakma, A., 1992, "A New Recovery Technique for Heavy Oil Reservoirs With Bottomwater", *SPE Res. Eng.*, vol. 7(2), 180–186.
- Kamel, J.M., and Yigit, A.S. Modeling and analysis of stick-slip and bit bounce in oil well drillstrings equipped with drag bits, *J. Sound Vib.* 333 (2014) 6885–6899.
- Kapitaniak, M. et al., 2015, Unveiling complexity of drill-string vibrations: experiments and modelling, *Int. J. Mech. Sci.* 101–102 (2015) 324–337.
- Khan, K. and Al-Anazi, H.A., 2016, Optimum Mud Overbalance and ROP Limits for Managing Wellbore Stability in Horizontal Wells in a Carbonate Gas Reservoir, *Saudi Aramco Journal of Technology*, Spring.
- Knight, M.J. and Brennan, F.P., 1999, Fatigue life improvement of drill collars through control of bore eccentricity, *Eng. Fail. Anal.* 6. 301–319.
- Knight, M.J. Brennan, F.P. and Dover, W.D. Controlled failure design of drillstring threaded connections, *Fatigue Fract. Eng. Mater. Struct.* 26 (2003) 1081–1090.
- Knight, M.J., Brennan, F.P., Dover, W.D., 2003, Controlled failure design of drill-string threaded connections, *Fatigue Fract. Eng. Mater. Struct.* 26, 1081–1090.
- Kular, S.S., 2016, Challenges related to magnetics and navigation within directional drilling, MS Thesis, Dept. of Petroleum Engineering, University of Stavanger, Norway.
- Luo, S. Wu, S., 2013, Effect of stress distribution on the tool joint failure of internal and external upset drill pipes, *Mater. Des.* 52 (2013) 308–314.
- Mehdi Hajianmaleki, J.S.D., 2014, Advances in critical buckling load assessment for tubulars inside wellbores, *J. Pet. Sci. Eng.* 116 (2014) 136–144.
- Moradi, S. and Ranjbar, K. Experimental and computational failure analysis of drillstrings, *Eng. Fail. Anal.* 16 (2009) 923–933.

- Moradi, S., Ranjbar, K., 2009, Experimental and computational failure analysis of drillstrings, *Eng. Fail. Anal.* 16, 923–933.
- Noureldin, A., 2002, New Measurement-While-Drilling Surveying Technique Utilizing Sets of Fiber Optic Rotation Sensors, PhD dissertation, Dept. of Electrical and Computer Engineering, University of Calgary.
- Perrin, J., 2016, Oil wells drilled horizontally are among the highest-producing wells, *IEA Today in Energy*, Nov. 4.
- R.-h. Wang, Y.-b. Zang, R. Zhang, Y.-h. Bu, H.-z. Li, Drillstring failure analysis and its prevention in northeast Sichuan, China, *Eng. Fail. Anal.* 18 (2011) 1233–1241.
- Rahim, Z., *et al.*, 2012, Successful drilling of lateral wells in minimum horizontal stress direction for optimal fracture placement, *Oil and Gas Journal*, Dec. 03.
- Russell A.W. and Roesler R.F., 1985, Reduction of Nonmagnetic Drill Collar Length through Magnetic Azimuth Correction Technique, in proceedings of SPE/IADC Drilling Conference, New Orleans, LA, Mar 6–8.
- Russell A.W. and Russell M.K., 1991, Surveying of Boreholes, U.S. patent No. 4, 999, 920, *March*.
- Russell A.W., 1989, Method of Determining the Orientation of a Surveying Instrument in a Borehole, U.S. patent No. 4, 819, 336, *April*.
- Russell M. and Russell A.W., 2003, Surveying of Boreholes, U.S. patent No. 6, 637, 119 B2, *October*.
- Russell M.K. and Russell A.W., 1979, Surveying of Boreholes, U.S. patent No. 4, 163, 324, *August*.
- Soeder, D.J., 2018, The successful development of gas and oil resources from shales in North America, *J. Pet. Sci. Eng.*, 163, 399–420.
- Sun, Y., Yu, Y., Liu, B., 2015, Closed form solutions for predicting static and dynamic buckling behaviors of a drillstring in a horizontal well, *Eur. J. Mech. Solids* 9, 362–372.
- Tellefsen, K., 2011, Effect of Drilling Fluid Content on Directional Drilling: Shielding of Directional Magnetic Sensor in MWD Tools, MS Thesis, Norwegian University of Science and Technology (NTNU).
- W.H. Wamsley Jr., R.F. Smith, Introduction to roller-cone and polycrystalline diamond drill bits, *Petroleum Engineering Handbook*, SPE publication 2015, pp. 221–264.
- Wood, David and Mokhatab, Saeid, 2006, Deepwater projects present surface, downhole challenges, *Oil & Gas Journal*, Dec 4.
- Xu, S., Liu, Y.-z., Zhou, L.-y., Yan, Y.-m, and Zhu, H.-w. Failure analysis of the 18CrNi3Mo steel for drilling bit, *J. Fail. Anal. Prev.* 14 (2014) 183–190.
- Yonggang, L., *et al.*, 2011, Simulation technology in failure analysis of drill pipe, *Procedia Eng.* 12, 236–241.
- Zhu, X., Dong, L., Tong, H., 2013, Failure analysis and solution studies on drill pipe thread gluing at the exit side of horizontal directional drilling, *Eng. Fail. Anal.* 33, 251–264.



# 11

## Environmental Hazard and Problems during Drilling

### 11.0 Introduction

Energy is the lifeblood of the Earth and the driver of modern civilization, and as such the energy sector plays the most important role in expanding the global economy (Islam *et al.*, 2017). The petroleum sector has been the pioneer of energy management since the 1950s. Starting in the 1950s, oil and natural gas became the main sources of primary energy for the increasing world population, and this dominance is expected to continue for the foreseeable future (several more decades) (Energy Information Administration [EIA], 2017). Oil remains the world's leading fuel, accounting for a third of global energy consumption. In recent years, oil increased its global market share for two years in a row, following 15 years of decline from 1999 to 2014 (BP, 2017).

In the United States, petroleum production started in 1859 when Drake's well was drilled near Titusville, Pennsylvania, and oil and natural gas currently supply approximately the majority of energy consumption – a trend likely to continue for decades to come (BP, 2017). Even though significant efforts have been made in alleviating environmental impacts, it

is recognized that the benefits of petroleum consumption can carry major environmental impacts that may be regional or global in scale, including air pollution, global climate change, and oil spills. Although the bulk of this impact takes place after a well is completed and production is commenced, there is a significant risk of negative environmental impact if a drilling process encounters problems.

This concern has been highlighted after the disastrous April 20, 2010, accident during a drilling operation in the Gulf of Mexico. This large offshore oil spill resulted in the “worst environmental disaster” in U.S. history. The Macondo blowout occurred after a dramatic, three-decade long reconfiguration of how the United States and several other nations drill for oil. Technology, law and geology made it possible for oil exploration to move farther from shores, as land-based exploration became less fruitful, and the global demand for energy ramped up. The Macondo blowout was a sequence of events with high complexity, large uncertainty and severe consequences. However, this disaster manifested through failure of the drilling operation. As such, it was considered to be a drilling problem that should have been rectified with proper planning.

In this chapter, we consider environmental impacts of drilling-related problems. It is not merely a matter of safety or operational hazard issue and as such we consider long-term impacts of various failures.

## **11.1 Problems Related to Environment during Drilling**

Oil and gas extraction is the source of constant environmental pollution. The most difficult process in the oil and gas industry is drilling. There are several potential sources of pollution on the rig. One of the main ones is the pump-circulation system of the drilling rig, which is associated with flushing wells drilled. To wash the wells with the drilling mud it is used with appropriate rheological properties, ensuring perfect cleaning bottom hole drilled from rocks and optimum hydraulics bit, etc.

Each phase of a drilling operation involves activities that will have long-term environmental consequences. It ranges from exploratory drilling to developmental and expansion drilling projects (Boothe and Presley, 1987). Even though tremendous improvements have been done in introducing sustainable practices, drilling-related environmental consequences continue (Kharak and Dorsey, 2005). Impacts due to drilling would be similar to those for exploration, but would be more extensive due to an increased number of wells, access roads, pipelines, and other ancillary

facilities (e.g., compressor stations or pumping stations) that are required. Typical activities during the drilling and development of an oil or gas well include ground clearing and removal of vegetative cover, grading, drilling, waste management, vehicular and pedestrian traffic, and construction and installation of facilities. All these activities have long-term consequences to the environment.

### 11.1.1 Environmental Degradation

In areas for which oil and gas development is prevalent, water, air and soil resources can become contaminated with oil and gas wastes and by-products. However, what is often overlooked is the contamination caused by chemicals and others that are caused by procedures used during a drilling or production operation. Activities that may cause environmental impacts include ground clearing, grading, waste management, vehicular and pedestrian traffic, and construction and installation of facilities before even drilling starts. After drilling is completed, clean-up activities will continue to leave behind footprints that will have a long-term impact on the environment. Activities conducted in locations other than at the oil and gas well pad site may include excavation/blasting for construction materials (sands, gravels), access road and storage area construction, and construction of gathering pipelines and compressor or pumping stations. The following are some of the major causes of environmental degradation.

#### 11.1.1.1 *Acoustics (Noise)*

Primary sources of noise during the drilling/development phase would be equipment (bulldozers, drill rigs, and diesel engines). This noise has both health and environmental consequences. Health and safety concerns are usually addressed by requiring that the drilling crew wear protective gear. However, long-term environmental concerns cannot be addressed. At present, we don't have the scientific ability, let alone engineering regulations to protect the environment (Khan and Islam, 2016).

Other sources of noise include vehicular traffic and blasting. Blasting activities typically would be very limited, the possible exception being in areas where the terrain is hilly and bedrock shallow. With the exception of blasting, noise would be restricted to the immediate vicinity of the work in progress. Noise from blasting would be sporadic and of short duration but would carry for long distances. As such, noise pollution in drilling is similar to that during exploration, in which explosives are used as part of the geophysical surveys. If noise-producing activities occur near a residential area, noise levels from blasting, drilling, and other activities could exceed

the U.S. Environmental Protection Agency (EPA) guidelines (EPA, 2016). The movement of heavy vehicles and drilling could result in frequent-to-continuous noise that would have long-lasting impact although intangible with conventional tools.

The highest noise levels would occur from drilling and flaring of gas. Gas flaring is the burning of natural gas that is associated with crude oil when it is pumped up from the ground. In petroleum-producing areas where insufficient investment was made in infrastructure to utilize natural gas, flaring is employed to dispose of this associated gas. For drilling, flaring is a standard practice whenever a zone of non-target gas formation is drilled through. In addition to noise, flared gases produce environmentally damaging oxides.

Increased vehicle traffic at oil drilling sites contributes significantly to noise pollution in wildlands. Wild mammals and birds respond to noise disturbances with short-term avoidance behavior, but many studies have shown that these behaviors become habituated. In scientific terms, it means nature is capable of absorbing the damage caused by the noise pollution but does compensate for it through adjustments that may result in long-term negative impacts. Negative impacts include disruption of song-bird communication in breeding and nesting seasons, as well as altered predator and prey dynamics. Mammals not habituated to traffic may be more vulnerable to road kill.

Noise dispersion from the flare station is adversely felt within 20–80 m from the flare station (Ismail and Umukoro, 2012). Noise from drilling has been measured as 115 dBA at the source to above 55 dBA at distances 1,800 feet (549 meters) to 3,500 feet (1,067 meters) from the well. Drilling noise would occur continuously for 24 hours per day for one to two months or more depending on the depth of the formation. Exploratory wells that end up becoming production wells would continue to generate noise during the production phase.

#### 11.1.1.2 *Air Quality*

Emissions generated during the drilling/development phase include vehicle emissions, power generators, diesel emissions from large construction equipment and generators, storage/dispensing of fuels, and, in many instances, flare stacks; small amounts of carbon monoxide, nitrogen oxides, and particulates from blasting activities; and dust from many sources, such as disturbing and moving soils (clearing, grading, excavating, trenching, backfilling, dumping, and truck and equipment traffic), mixing concrete, and drilling. During any accident, the rate of air pollution is much higher than what it is during normal operations. During windless conditions

(especially in areas of thermal inversion), project-related odors may be detectable at more than a mile from the source. Excess increases in dust could decrease forage palatability for wildlife and livestock and increase the potential for dust pneumonia.

Often, major pollution during drilling comes from gas flaring. Environmental issues of gas flaring are generally described in terms of efficiency and emissions (Gobo *et al.*, 2009). It is widely acknowledged that flaring and venting of associated gas contributes significantly to greenhouse gas (GHG) emissions and has negative impacts on the environment. For example, flaring/venting during oil production operations emits CO<sub>2</sub>, methane and other forms of gases, which contribute to global warming causing climate change. Of more significance for the short-term impact is the effects on the environmental quality and health of the vicinity of the flares.

There is also the fugitive emission. Fugitive emissions are unintentional leaks of gases. This may occur from breaks or small cracks in seals, tubing, valves or pipelines, as well when lids or caps on equipment or tanks have not been properly closed or tightened. When natural gas escapes via fugitive emissions, methane as well as volatile organic compounds (VOCs) and any other contaminants in the gas (e.g., hydrogen sulfide) are released to the atmosphere.

Contamination of oil and gas facilities with naturally occurring radioactive materials (NORM) is widespread. NORM contamination can be expected at nearly every petroleum facility. Some of it can be sufficiently severe that maintenance and other personnel may be exposed to hazardous concentrations. In addition, the industry must comply with new regulations. Two general types of common NORM contamination will be controlled by these regulations.

1. Radium contamination of petroleum production facilities – specifically of pipe scale and sludge and scale in surface vessels. In addition, produced water may be radioactive from radium dissolved in underground water.
2. Radon contamination of natural-gas production facilities. This includes contamination with the long-lived decay products of radon. Facilities that remove ethane and propane from natural-gas facilities are especially susceptible to NORM contamination.

Radium has been known as a trace contaminant of underground water for a long time but wasn't reported to be a contaminant of scale until the early 1980s, when the problem was first reported in the North Sea.

Radon contamination of natural gas has been known for nearly 100 years. However, it was only in 1971 that radon was found to concentrate in the lighter natural-gas liquids during processing and could present a serious health hazard to industry personnel, particularly maintenance employees. The radioactive scale problem in the oil and gas industry has been reported in the literature. With the notable exception of a 1975 report by Gese and a paper by Gray in 1990, NORM contamination of gas facilities by radon and its decay products has not been as extensively reported. Gray (1993) concluded in his paper these points:

1. NORM contamination can be expected at nearly every petroleum facility.
2. The presence of NORM in oil and gas production facilities, gas processing plants, pipelines, and other petroleum equipment and facilities is not, in general, a serious technical problem.
3. Radium contamination of pipe scale can be a serious problem requiring special procedures for the removal and disposal of contaminated scale to prevent contamination of personnel and the environment.
4. Produced water may be contaminated with radium, requiring special procedures for the protection of the environment.
5. Surface equipment and facilities at production sites also may be contaminated with NORM, requiring special repair and maintenance procedures and the disposal of NORM-contaminated wastes.
6. A serious problem that must be addressed is the disposal of radioactive materials and equipment. Options available for the disposal of NORM and NORM-contaminated wastes are limited.

#### *11.1.1.3 Contamination during Drilling*

During the drilling process, numerous chemicals are added to the mud system. These chemical components often have high toxicity (Myrzagaliyeva and Zaytsev, 2012). During the drilling process mud becomes saturated with other indigenous chemicals, such as hydrogen sulfide, radioactive elements and other substances hazardous to staff health and the environment (Bakhtyar and Gagnon, 2012). Drilling oil and gas wells release several contaminants during the process. These include: (i) hydrogen sulfide; (ii) diesel fuel; (iii) methane; (iv) benzene, toluene, ethyl benzene and

xylenes (BTEX); (v) nitrogen oxides; (vi) toxic metals; (vii) polycyclic aromatic hydrocarbons; and (viii) sulfur dioxide. These chemicals can cause both acute and chronic respiratory illnesses, including asthma, bronchitis, emphysema pneumonia, and pulmonary edema. They can also affect mental functioning, contribute to neurological disorders, high blood pressure and heart disease. Drilling contamination can be divided into separate stages (Shkitsa and Yatsyshyn, 2012):

1. washing wells during drilling, drilling fluid leakage from the high temperature wells, revenues in its cleaning unit, where the intense evaporation is taking place and its transportation to the container;
2. lifting drilling tool 2–6 thousand meters or more from the well with a layer of mud outside drilling string.

Reducing exposure to harmful vapors personnel and the environment during the first phase is proposed to implement by using sealed and modernized equipment items of pump circulation system described by Shkitsa and Yatsyshyn (2012). Tackling pollution mud as a result of lifting drilling tools needs analyzing processes that occur during the drilling equipment that purifies downhole tool.

Series of contaminations can arise from the engines used during the drilling process. Drilling, completion and workover trucks, rigs and equipment such as pumps typically run off of diesel-powered or gasoline engines. The exhaust fumes from gasoline and diesel fuels can produce emissions that are noticeable to people living downwind. Polycyclic aromatic hydrocarbons (PAHs) are found in exhaust from motor vehicles and other gasoline and diesel engines. A long list of other air pollutants, including nitrogen oxides, carbon monoxide, BTEX, formaldehyde and metals are also contained in diesel fuel combustion products.

Earthen pits are often used to store or evaporate produced water and wastewater from natural gas dehydration or oil/gas separation units. Additionally, prior to disposal drilling wastes (muds and cements) and fracking wastes are often stored in earthen or metal pits that are open to the air. There are hundreds of different chemicals that may be used during drilling, fracking and workover procedures, including acids, biocides, surfactants, solvents, lubricants and others. In general, soil pollution can emerge from any of the following:

1. Oil and gas industry wastes, which may contain petroleum hydrocarbons, metals, naturally occurring radioactive

- materials, salts and toxic chemicals, have the potential to cause soil pollution, and prevent the growth of vegetation.
2. Produced water, which may contain high concentrations of salts and other contaminants, is often stored in pits or disposed of in evaporation ponds. Spills of produced water can kill vegetation and sterilize soils.
  3. Contaminants that enter the soil do not necessarily stay put. They can move down through the soil and contaminate groundwater, or up through the soil and be released to the air.

#### 11.1.1.4 *Cultural Resources*

Potential impacts to cultural resources during the drilling/development phase could include:

1. destruction of cultural resources in areas undergoing surface disturbance;
2. unauthorized removal of artifacts or vandalism as a result of human access to previously inaccessible areas (resulting in lost opportunities to expand scientific study and educational and interpretive uses of these resources); and
3. visual impacts resulting from large areas of exposed surface, increases in dust, and the presence of large-scale equipment, machinery, and vehicles for cultural resources that have an associated landscape component that contributes to their significance (e.g., sacred landscapes or historic trails).

While the potential for encountering culturally sensitive sites is relatively low, the possibility that such sites would be disturbed during pipeline, access road, or well pad construction does exist. Unless the sacred site is detected early in the surface-disturbing activities, the impact to the site can be considerable. Disturbance that uncovers cultural resources of significant importance that would otherwise have remained buried and unavailable could be viewed as a beneficial impact. Vibration, resulting from increased traffic and drilling/development activities, may also have effects on rock art and other associated sites (e.g., sites with standing architecture).

#### 11.1.1.5 *Ecological Resources*

Impacts to ecological resources would be proportional to the amount of surface disturbance and habitat fragmentation. Vegetation and topsoil



would be removed for the development of well pads, access roads, pipelines, and other ancillary facilities. This would lead to a loss of wildlife habitat, reduction in plant diversity, potential for increased erosion, and potential for the introduction of invasive or noxious weeds. The recovery of vegetation following interim and final reclamation would vary by community (e.g., grasslands would recover before sagebrush or forest habitats).

Indirect impacts to vegetation would include increased deposition of dust, spread of invasive and noxious weeds, and the increased potential for wildfires. Dust settling on vegetation may alter or limit plants' abilities to photosynthesize and/or reproduce. Over time, a composition of native and/or invasive vegetation would become established in areas disturbed by wildfire. Although oil and gas field development would likely increase the spread of invasive and noxious weeds by increasing traffic and human activity, the potential impacts could be partially reduced by interim reclamation and implementation of mitigation measures. Adverse impacts to fish and wildlife could occur during the drilling/development phase from: (i) erosion and runoff; (ii) dust; (iii) noise; (iv) introduction and spread of invasive nonnative vegetation; (v) modification, fragmentation, and reduction of habitat; (vi) mortality of biota; (vii) exposure to contaminants; (viii) interference with behavioral activities; and (ix) increased harassment and/or poaching.

Depletion of surface waters from perennial streams could result in a reduction of water flow, which could lead to habitat loss and/or degradation for aquatic species.

#### *11.1.1.6 Environmental Justice*

If significant impacts were to occur in any of the resource areas and these were to disproportionately affect minority or low-income populations, there could be an environmental justice impact. Even though the role of environmental justice (or injustice) was understood during the era of the civil rights movement, the term has been receiving serious consideration only during last few decades (EPA, 2016). It is anticipated that the development could benefit low-income, minority, and tribal populations by creating job opportunities and stimulating local economic growth via project revenues and increased tourism. However, noise, dust, visual impacts, and habitat destruction could have an adverse affect on traditional tribal lifeways and religious and cultural sites. Development of wells and ancillary facilities could affect the natural character of previously undisturbed areas and transform the landscape into a more industrialized setting. Development activities could impact the use of cultural sites for traditional

tribal activities (hunting and plant-gathering activities, and areas in which artifacts, rock art, or other significant cultural sites are located).

#### *11.1.1.7 Hazardous Materials and Waste Management*

Solid and industrial waste would be generated during development and drilling activities. Much of the solid wastes would be expected to be non-hazardous; consisting of containers and packaging materials, miscellaneous wastes from equipment assembly and presence of construction crews (food wrappers and scraps), and woody vegetation. Industrial wastes would include minor amounts of paints, coatings, and spent solvents. Most of these materials would likely be transported off-site for disposal. In forested areas, commercial-grade timber could be sold, while slash may be spread or burned near the well site.

Drilling wastes include hydraulic fluids, pipe dope, used oils and oil filters, rigwash, spilled fuel, drill cuttings, drums and containers, spent and unused solvents, paint and paint washes, sandblast media, scrap metal, solid waste, and garbage. Wastes associated with drilling fluids include oil derivatives, e.g., polycyclic aromatic hydrocarbons (PAHs), spilled chemicals, suspended and dissolved solids, phenols, cadmium, chromium, copper, lead, mercury, nickel, and drilling mud additives (including potentially harmful contaminants such as chromate and barite). Adverse impacts could result if hazardous wastes are not properly handled and are released to the environment.

Produced water (water that coexists with oil and gas in the formation and is recovered during well development) generation can be an issue during the drilling/development phase, although it usually becomes a greater waste management concern over the long-term operation of an oil or gas field because water production typically increases with the age of the production well. One exception to this is the drilling and development of coalbed methane reserves; produced water is generated at high volumes during the initial completion and development of coalbed methane wells and then declines considerably as methane production increases. Regulations govern the disposal of this produced water; the majority of it is disposed of by underground injection either in disposal wells or, in mature producing fields, in enhanced oil recovery wells (i.e., wells by which produced water and other materials are injected into a producing formation in order to increase formation pressure and production).

In some locations, produced water may carry naturally occurring radioactive materials (NORM) to the surface. Typically, the NORM radionuclides (primarily radium-226, radium-228, and their progeny) are dissolved

in the produced water but a portion of the NORM can precipitate into solid form in scales and sludges that collect in pipelines and storage vessels. Proper management of NORM-bearing produced water and solid wastes is critical to prevent both occupational and public human health risks and environmental contamination. NORM wastes are a problem generally associated with long-term operation of an oil or gas field, but can also be associated with the drilling/development phase. The NORM Technology Connection website provides information about the regulation of NORM bearing wastes generated by the petroleum industry.

#### *11.1.1.8 Health and Safety*

Potential impacts to worker and public health and safety during the drilling/development phase would be similar to other projects that involve earthmoving, use of large equipment, transportation of overweight and oversized materials, and construction and installation of industrial facilities. The risks of serious accidents or injuries associated with oil and gas production apply primarily to well site workers. Statistical data on occupational accidents and fatalities for the oil and gas extraction labor category are available from the U.S. Bureau of Labor Statistics. In 2005, the oil and gas industry experienced a nationwide rate of 2.1 accidents per 100 full-time workers and 25.6 fatalities per 100,000 workers. Potential for occupational accidents and mortality would be highest during peak drilling periods and would likely drop in proportion to the decline in drilling and development activities.

The development of oil and gas includes the potential for well fires or explosions. Well blowouts are rare but can be extremely dangerous (e.g., they can destroy rigs and kill nearby workers). They usually occur during drilling but can also occur during production (especially during well workover operations). If natural gas is in the blowout materials, the fluid may ignite from an engine spark or other source of flame. Blowouts may take days to months to cap and control. Also, increased human activity and increased public access could result in a higher potential for wildfires in the production area. Workers could also be exposed to air pollutants and could have body contact with product or other chemicals. Reckless driving by oil or gas workers would also create safety hazards. In addition, health and safety issues include working in potential weather extremes and possible contact with natural hazards, such as uneven terrain and dangerous plants, animals, or insects.

In locations where NORM-bearing produced water and solid wastes are generated, occupational and public health risks may occur if the wastes are not properly managed.

#### 11.1.1.9 *Land Use*

Land use impacts would occur during the drilling/development phase if there are conflicts with existing land use plans and community goals; existing recreational, educational, religious, scientific, or other use areas; or existing commercial land use (e.g., agriculture, grazing, or mineral extraction). In general, the development of oil and gas facilities would change the character of the landscape from a rural to a more industrialized setting. Existing land use would be affected by intrusive impacts such as increased traffic, noise, dust, and human activity, as well as by changes in the visual landscape. In particular, these impacts could affect recreationists seeking solitude or recreational opportunities in a relatively pristine landscape. Ranchers or farmers could be affected by loss of available grazing or crop lands, potential for the introduction of invasive and noxious plants that could affect livestock forage availability, and possible increases in livestock/vehicle collisions. In forested areas, oil and gas well drilling could result in the long-term loss of timber resources. The expanded access road system could increase the number of off-highway vehicle (OHV) users, hunters, and other recreationists in the area. While the change in landscape character could discourage hunters who prefer a more remote back-country setting; the potential for illegal hunting activities could increase due to the expanded access road system. Construction and drilling noise could potentially be heard 20 miles (32 kilometers) or more from the project area. While it would be barely audible at this distance, it could affect residents' and recreationists' perceptions of solitude.

Most land use impacts that occur during the drilling/development phase would continue throughout the life of the oil and gas field. Overall, land use impacts could range from minimal to significant depending upon both the areal extent of the oil and gas field, the density of wells and other ancillary facilities, and the compatibility of the oil and gas field with the existing land uses.

#### 11.1.1.10 *Paleontological Resources*

Impacts to paleontological resources can occur directly from construction and drilling activities or indirectly as a result of soil erosion and increased accessibility to fossil localities (e.g., unauthorized removal of fossil resources or vandalism to the resource). This would result in lost opportunities to expand scientific study and educational and interpretive uses of these resources. Disturbance that uncovers paleontological resources of significant importance that would otherwise have remained buried and unavailable could be viewed as a beneficial impact. Direct impacts to

unknown paleontological resources can be anticipated to be proportional to the total area impacted by drilling and development activities.

#### *11.1.1.11 Socioeconomics*

Drilling/development phase activities would contribute to the local economy by providing employment opportunities, monies to local contractors, and recycled revenues through the local economy. Additional revenues would be generated in the form of royalty payments to mineral rights owners and taxes collected by federal, state, and local governments. Indirect impacts could occur as a result of the new economic development (e.g., new jobs at businesses that support the expanded workforce or that provide project materials). Depending on the source of the workforce, local increases in population could occur. Development of an oil or gas field also could potentially affect property values, either positively from increased employment effects or negatively from proximity to the oil or gas field and any associated or perceived adverse environmental effects (noise of compressor stations, visual effects, air quality, etc.). Some economic losses could occur if recreationists (including hunters and fishermen) avoid the area. Increased growth of the transient population could contribute to increased criminal activities in the project area (e.g., robberies, drugs).

#### *11.1.1.12 Soils and Geologic Resources*

Potential impacts to soils during the drilling/development phase would occur due to the removal of vegetation, mixing of soil horizons, soil compaction, increased susceptibility of the soils to wind and water erosion, contamination of soils with petroleum products, loss of topsoil productivity, and disturbance of biological soil crusts. Impacts to soils would be proportionate to the amount of disturbance. Sands, gravels, and quarry stone could be excavated for use in the construction of access roads; foundations and ancillary structures; and for well pad and storage areas. Construction of well pads, pipelines, compressor or pumping stations, access roads, and other project facilities could cause topographic changes. These changes would be minor, but long term. Well pads located on canyon rims or the side slopes of canyons could result in bedrock disturbances. Additional bedrock disturbance could occur due to construction of access roads, pipelines, rock borrow pits, and other ancillary facilities. Possible geological hazards (earthquakes, landslides, and subsidence) could be activated by drilling and blasting. Altering drainage patterns could also accelerate erosion and create slope instability.

#### 11.1.1.13 *Transportation*

Development of an oil and gas field would result in the need to construct and/or improve access roads and would result in an increase in industrial traffic (e.g., hundreds of truck loads or more per well site). Overweight and oversized loads could cause temporary disruptions and could require extensive modifications to roads or bridges (e.g., widening roads or fortifying bridges to accommodate the size or weight of truck loads). An overall increase in heavy truck traffic would accelerate the deterioration of pavement, requiring local government agencies to schedule pavement repair or replacement more frequently than under the existing traffic conditions. Increased traffic would also result in a potential for increased accidents within the project area. The locations at which accidents are most likely to occur are intersections used by project-related vehicles to turn onto or off highways from access roads. Conflicts between industrial traffic and other traffic are likely to occur, especially on weekends, holidays, and seasons of high use by recreationists. Increased recreational use of the area could contribute to a gradual increase in traffic on the access roads. Over 1,000 truckloads per well could be expected during the drilling/development phase.

#### 11.1.1.14 *Water Resources*

Impacts to water resources could occur due to water quality degradation from increases in turbidity, sedimentation, and salinity; spills; cross-aquifer mixing; and water quantity depletion. During the drilling/development phase, water would be required for dust control, making concrete, consumptive use by the construction crew, and in drilling of wells. Depending on availability, it may be trucked in from off-site or obtained from local groundwater wells or nearby surface water bodies. Where surface waters are used to meet drilling and development needs, depletion of stream flows could occur. Drilling and well development often remove enormous amounts of groundwater, referred to as produced water. The generation of produced water can create several problems: water may be depleted from nearby aquifers; and produced groundwater that is saline or contaminated with drilling fluids can contaminate soils or surface waters, if brought to the surface and not reinjected to a suitable subsurface unit. Produced water also may contain organic acids, alkalis, diesel oil, crankcase oils, and acidic stimulation fluids (e.g., hydrochloric and hydrofluoric acids).

Drilling activities may affect surface and groundwater flows. If a well is completed improperly such that subsurface formations are not sealed off by the well casing and cement, aquifers can be impacted by other non-potable

formation waters. The interaction between surface water and groundwater may also be affected if the two are hydrologically connected, potentially resulting in unwanted dewatering or recharging. Soils compacted on existing roads, new access roads, and well pads generate more runoff than undisturbed sites. The increased runoff could lead to slightly higher peak storm flows into streams, potentially increasing erosion of the channel banks. The increased runoff could also lead to more efficient sediment delivery and increase turbidity during storm events.

### 11.1.2 Drill Cutting Management

Drill cuttings are an integral part of the drilling process. As early as the early 1900s the mud system was introduced as a part of rotary drilling. In the beginning of this technology development, a significant problem associated with these fluids was the low flash point of the volatile fractions within the crude, and the associated safety concerns. At that time, cutting management wasn't a concern as they were routinely disposed on land without worrying about regulations. As time progressed, more and more chemical additives were added to the mud system, raising concerns about the safe disposal of drilling fluids. It wasn't until the 1980s that cuttings themselves created a problem in terms of environmental restoration. As for offshore drilling, cuttings were dumped straight into the ocean. Today, 77% of all marine pollution is caused by land-based human activities, but these sources remain largely hidden from view (Moreau, 2009). GESAMP (1996) reported that the main sources of man-made (global) marine oil pollution are: (i) land-based discharges and run-off (including rivers) 44%; (ii) the atmosphere 33%; (iii) maritime transport 12%; (iv) dumping 10%; (v) offshore oil and gas production 1%.

Input of petroleum pollution into the global marine environment has been estimated at 6 million tons annually, with the majority coming from daily influxes rather than disasters (Turner, 2002). However, oil tanker accidents and oil well blowouts result in serious damage, due to the concentration of the contamination; the physical properties of oil lead to its coating of sea creatures, such as birds and mammals, causing death, as well as the coating of any beach it happens to be washed onto, sometimes destroying whole ecosystems. Although these incidents only account for a small fraction of the total amount of oil that reaches the sea, their impact can be massive. Oil-spill incidents have a powerful negative impact on public opinion.

The UK Offshore Operators Association (UKOOA) reports give the sources of oil discharge into the North Sea as: 26% Ships, 21% Rivers and Runoff, 20% Offshore Oil and Gas (including oil on cuttings), 7%

Atmospheric, 7% Other Costal Effluent, 6% Coastal Sewage, 4% Dredged Spoil, 3% Sewage Sludge, 3% Coastal Refineries, and 3% Others.

These reports have an estimated 1–1.5 million tons of cuttings accumulated in the UK sector of the North Sea over 30 years of drilling activity. To get this into some perspective, it is equal to one twentieth of household waste per annum, and only one fiftieth of that produced by mining and quarrying, which is around 74 million tons annually.

Overall, North Sea operations have epitomized environmental pressure from oil and gas operations. As such, the North Sea is probably the most studied offshore oil and gas production area in the world. Formation water brought up with the hydrocarbons (produced water) and rock cuttings from drilling (drill cuttings) are the major sources of contaminants entering the sea from regular operations. Typically, drilling waste and produced water are cleaned by various physical means before discharge and regulations put strict limits on levels of contaminants that can be discharged to the sea. In addition, reinjection has been used to reduce overall discharges for many years. Displacement and drain water are also discharged, but the total amount of contaminants discharged is relatively low compared to the other two sources.

As stated earlier, until the mid-1990s the discharge of cuttings with oil-based drilling mud was the main source of oil hydrocarbons entering the marine environment from the offshore petroleum industry in the North Sea or any offshore operation. The average annual discharge of oil on cuttings to the Norwegian Continental Shelf (NCS) for the period 1981–1986 was 1940 tons (Bakke *et al.*, 2013). This source was gradually eliminated by regulation, in 1993 in Norway and in 1996 and 2000 within the OSPAR region (OSPAR Commission, 2000). Concurrently oil discharged with produced water on the NCS has increased and amounted to 1535 tons in 2012 (Norwegian Oil and Gas, 2013) i.e., almost level with the former peak discharges of oil on cuttings. This is primarily due to an increase in overall produced water volumes due to well ageing and rising number of producing fields.

As for drilling cuttings, large cuttings piles are still present in the northern and central part of the North Sea, and may have volumes of up to 45 000 m<sup>3</sup>, a height of up to 25 m, and a footprint of more than 20 000 m<sup>2</sup> (Breuer *et al.*, 2004). In the southern North Sea, the cuttings have not formed extensive deposits due to strong tidal and storm-driven currents. An inventory of cuttings piles present in the North Sea identified 79 large (>5000 m<sup>3</sup>) and 66 small (<5000 m<sup>3</sup>) piles on the UK and Norwegian Continental self (Bakke *et al.*, 2013). Aerobic biodegradation of the hydrocarbons occurs only in the upper few millimetres. Anaerobic degradation



may take place down to at least 20–50 cm, but only very slowly (Breuer *et al.*, 2004). The oil in deeper parts of the piles seems to be essentially unchanged (Breuer *et al.*, 2004). The focus of these studies is the toxicity of indigenous chemicals but in reality mud chemicals and additives offer far more threat to the environment.

On the policy side, with Greenpeace favoring a ship to shore policy and the UKOOA reports favoring leaving the drill cuttings on the sea floor, there is a stalemate in place. Moving the drill cutting piles would obviously disturb the seabed and release pollution into the area. Drilling the piles to allow aerobic bacteria to reach deep into the piles will also cause the release of pollutants, as well as reducing the available oxygen to the indigenous benthic communities, which could threaten their ecosystem. Biological modification of the piles may increase the biological effects by making the contaminant more accessible to marine flora and fauna (Bakke *et al.*, 2013).

Currently, the piles are not showing much evidence of remediation – even after 20 years (Turner, 2002), but do have sediment covering them and seem fairly stable. Anaerobic micro-organism activity by sulphur reducing bacteria (SRB) leads to the production of sulphides from metabolic respiration. Their release magnifies the toxicity of the drill cuttings and creates a corrosive, reducing environment. However, the underlying assumption is organic sulfur (such as the one produced by microorganisms) is as toxic as the synthetic one.

Offshore drill cuttings produced now are mostly shipped to shore where there are several options available for their disposal or treatment. For both offshore and onshore drill cuttings, the following options are available (Turner, 2002):

1. Reinjection: Annular reinjection is now utilized in a number of current drilling operations. Reinjection is dependent on the formation, as a solid cap rock is required to prevent returns to surface and contamination of other strata and aquifers. Power costs for reinjection may be considerable if cheaper power generation from produced gas is unavailable. Potential problems are reemergence of the cuttings and a lack of data for assessing the environmental impacts.
2. Landfill: Landfill is an option being utilized by many companies. In fact, this option has been in practice for decades. This is not ideal; landfill is not a treatment, but is simply moving an offshore problem onshore, where there is already pressure on waste disposal. Any option that takes the cuttings

onshore will have an environmental impact. While ending discharge from the rig, it increases pollution from shipping and heavy plant; the risk of spillages is higher and there is an increased risk of onshore air and groundwater pollution.

3. Incineration: Incineration can create atmospheric pollutants and, unless the energy is harnessed from the process, it is wasteful. Although technology has cleaned up emissions, incineration is not at all popular onshore, with the public strongly opposed to plants near any populated or environmentally sensitive areas. Fuel would have to be added to sustain the process, making it a high cost option. Offshore incineration at source or a modified installation elsewhere may be technically feasible, but is “not considered cost-effective or environmentally acceptable”. Incineration as a whole can be rendered cost effective if in-situ waste gas can be used and the incinerated product be utilized in a value-added capacity. This remains a research topic and is far from being tested in a pilot project, let alone being implemented in the field.
4. Solvent Extraction: Technically solvent extraction is possible, but remains an expensive option. It also has a contamination problem as the pollutant is moved into the solvent. The pollutant then needs to be removed from the solvent, and treated. Both extractions can prove expensive.
5. Distillation/Thermal Desorption: This involves the use of heat to separate the oil from the cuttings, enabling the oil to be reclaimed. Process costs may be high. Distillation is only suitable for mineral oils, some paraffins and poly alpha olefins. Most of the other synthetics used, including esters and linear alpha olefins (LAOs), are unsuitable due to the high-water content in the cuttings; at temperatures used in distillation this may cause the hydrocarbon chains to split, generating toxic or volatile fractions, which would make them unsuitable for reuse.
6. De-emulsification: Separating the oil and water by attacking the emulsifier, either chemically or biologically, is an attractive option. Chemical separation can prove costly, and may introduce another contaminant. Mechanical separation can involve ultrasonic treatment, but has yet to reach commercial application. Biological destruction of the oil/water bond seems to be a sustainable option, and one that could benefit from further investigation.

7. Flotation: Oil is used as a flotation agent for coal fines, and is especially efficient in water with high chloride content. Oil is used in the coal industry for flotation, as the oil attaches itself to the coal. If the cuttings were cleaned in this fashion, the final product could be sold as fuel, with the cuttings disposed of as a non-hazardous inert material. To date there is no evidence of research using this method.

#### *11.1.2.1 Regulatory Aspects of Drill Cutting Disposal*

The Convention for the Protection of the Marine Environment of the North-East Atlantic (the OSPAR Convention) was open for signature at the Ministerial Meeting of the Oslo and Paris Commissions in Paris on 22 September 1992. It was adopted together with a Final Declaration and an Action Plan. Contained within the OSPAR Convention are a series of Annexes which deal with the following specific areas:

- Annex I: Prevention and elimination of pollution from land-based sources;
- Annex II: Prevention and elimination of pollution by dumping or incineration;
- Annex III: Prevention and elimination of pollution from off-shore sources;
- Annex IV: Assessment of the quality of the marine environment;
- Annex V: On the protection and conservation of the ecosystems and biological diversity of the maritime area.

The convention focuses on safeguarding human health and conserves marine ecosystems by prevention pollution and adverse effects of human activities. The convention was designed for national enactment of rules and regulation towards the discharge of offshore drilling wastes in the waters of the OSPAR signatory states: Belgium, Denmark, Finland, France, Germany, Iceland, Ireland, the Netherlands, Norway, Portugal, Spain, Sweden and the United Kingdom. OSPAR regulations thus cover all the oil-producing coastal states of Western Europe which came into force in 1998 after merging the Oslo Convention (1972) and Paris Convention (1974). There are other regulatory conventions/agreements. They are listed below.

1. **Helsinki Convention:** The Helsinki Convention, for the first time entered force in 1980. In view of the political changes, and developments in international environmental and

maritime law the convention was updated and was resigned 1992. The convention was signed by the states bordering the Baltic Sea, namely Denmark, Germany, Sweden, Estonia, Finland, Latvia, Lithuania, Poland and Russia. The purpose of the convention is to reduce pollution of the Baltic Sea area caused by discharges through rivers, estuaries, outfalls and pipelines, dumping and shipping operations as well as through airborne pollutants. The convention aimed at the sustainable development by controlling and preventing pollution and providing a framework for cooperation between the member countries of the United Nations Economic Commission for Europe.

2. **Barcelona Convention:** The convention aims at protection of the marine environment and coastal regions of the Mediterranean. The countries parties to the convention are to take all appropriate measures to prevent and abate pollution of the Mediterranean caused by dumping from ships and aircraft, or by discharges from ships, or resulting from exploration and exploitation of the sea bed and sub-soil, or from discharges from rivers, coastal establishments or other land-based sources within their territories.
3. **South Asian Seas Action Plan (SASAP):** The South Asian Seas region comprises the Indian Ocean and states like Pakistan, India, Maldives, Sri Lanka and Bangladesh. This region is rich in marine biological ecosystems. The countries are also thickly populated and consist of many industries which contribute significant threat to the coastline. The overall objective of SASAP is to protect and manage the marine environment and related coastal ecosystems leading towards a sustainable development.
4. **Land-Based Sources (LBS Protocol):** Taking this into consideration the global programme of action for the protection of the marine environment from land-based activities, the LBS protocol was adopted on 17 May 1980 for the protection of the Mediterranean Sea against pollution from land-based sources. The contracting parties are to take all possible appropriate measures to prevent, curtail, reduce and eliminate the possibility of polluting the Mediterranean Sea. The states are also encouraged to phase out substances that are toxic, persistent and liable to bioaccumulate.

5. **Protocol on Specially Protected Areas and Biodiversity:** Based on the convention on Biological Diversity (BCD) the protocol focused on establishment of special protected areas and provides guidelines for the conservation of the threatened species that prevail in the Mediterranean ecosystem special areas.
6. **Kuwait Convention:** The Kuwait Convention of 1978 is towards cooperation in protecting, curtailing and reducing the means of pollution in their common marine environment in spite of the existing geopolitical boundaries. The contracting states are Bahrain, Iran, Iraq, Kuwait, Oman, Qatar Saudi Arabia and the United Arab Emirates and consists of the sea referred to as the ROPME Sea Area.
7. **Abidjan Convention:** The Abidjan convention was adopted in March 1981 and subsequently entered into force on 5 August 1984. The convention focused on cooperation among central and West African states towards the protection and development of the marine and coastal environment. The states are advised to prevent, reduce, combat and control pollution of the area, particularly pollution from ships, aircraft, land-based sources, and activities relating to exploration and exploitation of the sea bed and pollution.
8. **Nairobi Convention:** The Nairobi Convention for the protection, management and development of the marine and coastal environment of the Eastern African Region was adopted in 1985 and subsequently came into force in 1996. There are nine contracting parties, namely Comoros, France, Kenya, Madagascar, Mauritius, Mozambique, Seychelles, Somalia, and Tanzania. The East African states being conscious of their responsibility realized that special care must be given and states must be held responsible towards management of the marine ecosystem.
9. **Lima Convention:** The Lima Convention for the protection of the marine environment and coastal areas of the South East Pacific was adopted in 1981 and came into force in 1986. There are four contracting parties, namely Chile, Colombia, Ecuador and Peru. The area under coverage of the convention is the South East Pacific within the 200-mile maritime area of the jurisdiction of the state parties. The contracting parties agreed to prevent, reduce and control pollution of the area particularly pollution from landbased

sources, vessels and from any other installations and devices operating in the marine environment.

### 11.1.3 Subsidence of Ground Surface

Every drilling operation involves creating an irreversible imbalance within the geomechanical infrastructure of the subsurface. During the production of operation, a tremendous amount of fluid is removed from the subsurface that can cause ground subsidence. Subsidence is the sinking or gradual lowering of the Earth's surface. It is found worldwide in a variety of environments on land and the seafloor. Subsidence can result from either natural geologic and/or man-made causes. Natural geologic causes are basin-downwarp, fault movement, sediment compaction, and relaxation of deep earth stresses. Man-made causes include groundwater pumping, mining, oil and gas production, river channelization, and surface loading. A subsided area can vary in size from a few acres to thousands of square miles. Elevation losses can be from a fraction of an inch to tens of feet. Damage can range from minor land elevation loss to costly infrastructure disruption and long-lasting environment damage. Ever since the time when Long Beach (California) became known as the "Sinking City", where up to 29 ft deep 'subsidence bowl' was created owing to oil and gas production from the Wilmington Oil Field, over 20 square miles have been affected adjacent to the shoreline from the Port to Seal Beach. In the early 1940s, groundwater pumping contributed to the land sinking, but the majority of the subsidence resulted from oil and gas extraction. Subsidence began in the 1940s with the pumping of underground water at Terminal Island Naval Shipyard. The area sank more than four feet by 1945, far more than attributed to groundwater withdrawal. In 1951, the rate of subsidence exceeded two feet per year. By 1958, the affected area was 20 square miles and extended beyond the Harbor District. Total subsidence reached 29 feet in the center of the "Subsidence Bowl". The ocean inundated wharves, rail lines and pipelines were warped or sheared, while buildings and streets were cracked and displaced. Ninety-five oil wells were severely damaged or sheared off by underground slippage. Oil, gas and water production caused pressure losses and the weight of the overburden compacted the oil sands. The surface sank in response to this underground compaction (Picture 11.1). These formations were particularly known to be shallow with production of large amount of reservoir sands along with oil and formation water.

In a petroleum operation in general, one of the best-known examples of geomechanics effects on reservoir-scale behavior is reservoir compaction



**Picture 11.1** Ground subsidence can be tangibly ‘felt’ in shallow reservoirs that produce oil and sand.

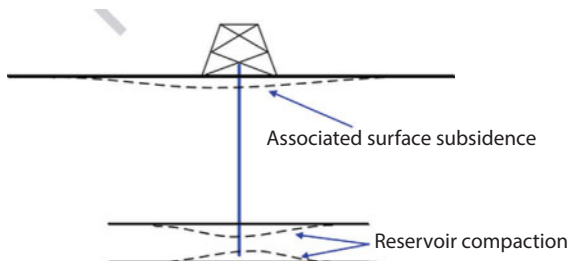

**Figure 11.1** Surface subsidence during oil/gas production.

and associated surface subsidence (see Figure 11.1) due to oil and/or gas withdrawal from reservoirs. Operational problems related to reservoir compaction may bring about negative results such as casing collapse, oil field structure and seabed pipeline damage and ground subsidence (Zhang, 2014). Here ground subsidence caused by reservoir compaction can usually provide valuable information for characterizing petroleum geomechanics properties during hydrocarbon production. This is mainly due to the fact that deformation characteristic of ground surface is one of the best representatives of reservoir and surrounding rock mass properties and it is convenient to be monitored by interferometric synthetic aperture radar (InSAR).

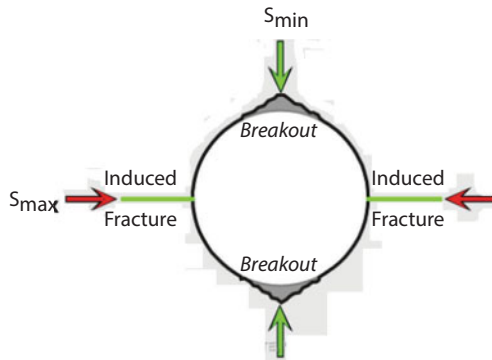

**Figure 11.2** Schematic cross-section of a wellbore deformation subjected to the maximum and minimum principal stress components (Al Lacazette, 2001).

Drilling in naturally fractured media generally involves a strong coupling between heat transfer, fluid flow and rock mass deformation (Dussault, 2011). This may lead to wellbore deformation during drilling. Well deformation consists of stress-induced breakouts and drilling-induced tensile wall-fracture on the wellbore wall as shown in Figure 11.2, and is quite common in many wells in petroleum engineering. Wellbore deformation is mainly the result of the following phenomena and factors (Aadnøy and Looyeh, 2011): (i) concentration of stress around wellbores; (ii) fluid–solid interaction; (iii) inconsistency or lack appropriate drilling and operating practices; and (iv) high pressure and temperature reservoirs.

Therefore, wellbore deformation occurs preferentially in the naturally fractured media due to mud loss, dilation and borehole pressure change while drilling. It is mainly contributed by both the intact rock and the presence of fractures under the effect of the earth stresses, and thus wellbore deformation yields valuable information for estimation of earth stress state as well as intact rock and natural fracture properties. In the meantime, wellbore deformation in terms of borehole size and shape is straightforward to be measured with the caliper logs or ultrasonic borehole televiewer logs (Zhang, 2014).

Subsidence involves a coupled problem related to all aspects of geomechanics. Because during a drilling process, the actual magnitude of subsidence is negligible, subsidence is not considered to be drilling-related. However, a drilling process can unlock tremendous amount of information that can be used later to determine an effective technique for combating subsidence. Major current challenges in this domain include: accurate delineation of in-situ physical properties and conditions ( $T$ ,  $[\sigma]$ ,



p), especially for naturally fractured reservoirs; wellbore wall stability predictions in swelling and fractured shale strata; modeling and monitoring of multiple-stage hydraulic fracturing used for development of resources in low-permeability rocks; controlling or exploiting sand ingress into producing wellbores; predicting subsidence accurately enough so that rational design decisions can be made; mitigating or reducing the incidence of casing shear arising from subsidence or thermal reservoir stimulation; understanding and analyzing thermal production processes in viscous oil reservoirs; monitoring of deformations in and around reservoirs being subjected to complex processes; and, a newer development, using the deep sedimentary basin environment for the permanent and secure disposal of fluid and granular wastes (Dusseault, 2011).

#### 11.1.4 Deep Water Challenges

Ever since the *Deepwater Horizon* drilling disaster in 2010, deep water drilling has received extraordinary attention from both safety and environmental perspectives. Deep water drilling creates a number of unique challenges, each carrying disastrous consequences if not considered during the planning stage. They are discussed below.

##### 11.1.4.1 Narrow Operational Window

One of the most difficult challenges of deep water drilling is the narrow window between pore and fracture pressure (Figure 11.3). The disparity occurs because of reduction in fracture pressure gradient and unusually high overburden pressure, which is mainly from the overlying deepwater layer. As a result, there is an overall reduction of the stress regimes in the rock, and reduction in fracture pressure. Additionally, the structurally weak, low compacted, and unconsolidated sediments commonly found in the shallower formations can often further reduce the fracture gradient. Under these circumstances, the operational window formed by the pore- and fracture pressure gradient will continually decrease as the water depth increases. In general, such a narrow window would dictate a large number of casing string, small hole sizes at target depth, excessive losses, hole problems or otherwise inability to reach target depth without exceeding fracture limits during well control operations (Aadnoy and Saetre, 2003).

##### 11.1.4.2 Marine Drilling Riser

As a result of moving into deeper waters, the design and integrity of the marine riser has become more important. Not only is the cost of acquiring

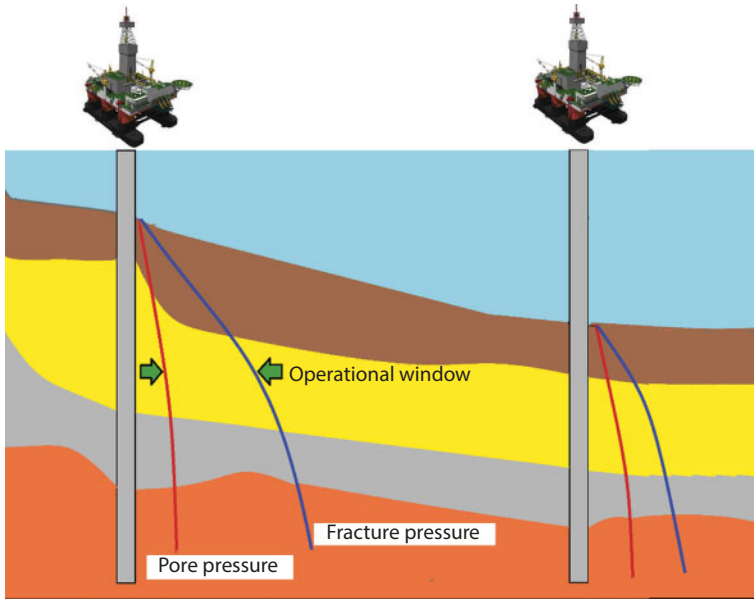
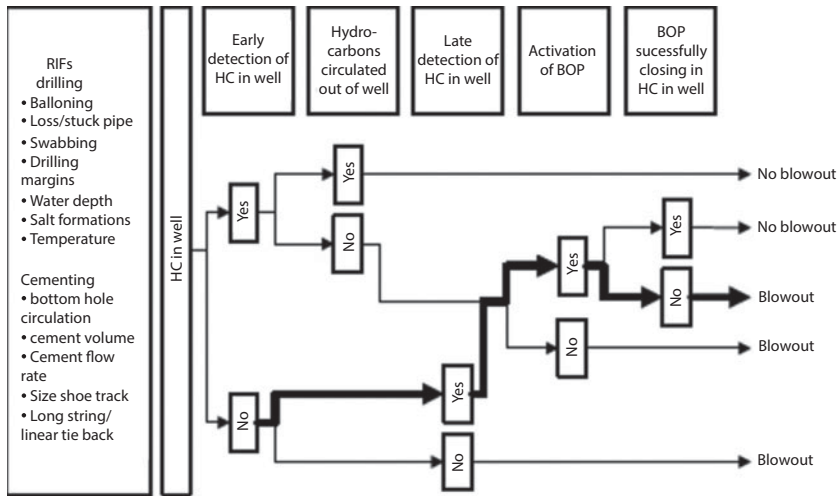

**Figure 11.3** Shallow water pore and fracture pressure vs. deep water. (From Wærnes, 2013).

an extra long riser high, but the time spent on running and retrieving the riser is much greater compared to normal water depths. Introducing a longer and subsequently heavier riser increases the loads experienced by the BOP and wellhead. Not just considering the static buoyed weight of the riser, but also the way it naturally moves with ocean currents, wave motion, pressure effects (burst/collapse), the rig moving in three dimensions, compressive and tensile loads, and thermal loads, are among some of the most reviewed by the literature. All of these are contributing to the overall stress regimes experienced at the wellhead and BOP, where maximum stresses are experienced. Not forgetting the load hanging from the drilling vessel when running or retrieving the riser, may require 5th and 6th generation drilling vessels. Special focus has however been put on developing slim, lightweight, strong and flexible systems to dampen the riser motion and related forces.

#### 11.1.4.3 Shallow Formation Hazards

The top soil of most formations share the risk of having multiple shallow hazards, including shallow gas, boulders, collapsing formations and shallow water flow, all of which are not exclusively deep water related problems, but somewhat more risk associated when introducing greater water



**Figure 11.4** Well hydrocarbon and kill operations during drilling (HC: Hydrocarbon in well; RIF: Risk Influencing Factors).

depths. For most cases, as the overburden is reduced, which is the case for deep water, it naturally follows that the unconsolidated formations are highly sensitive to flow and pressure changes. Operators have so far relied on using seismic data to quantify the risk of encountering these shallow hazard phenomenon on any given well. Most shallow hazards are typically located in the first 800m below the mud line and are often encountered while drilling in riser-less mode. Stopping the shallow water flows or gases from flowing into the wellbore can sometimes be difficult. Most of the time, increasing the mud weight is successful in remedying this problem. However, it comes with the pitfall that large quantities of weighted mud are lost to the ocean. If the shallow hazards are not properly accounted for, continuously flowing wells may undermine the structural integrity of the well and even affect neighbouring wells.

*11.1.4.4 Risk Analysis of Offshore Drilling*

Offshore drillings offer great challenges in terms of safety as well as long-term consequences. Skogdalen (2011) conducted a detailed analysis for offshore drilling. An example related to hydrocarbons in well and kill operations is shown in Figure 11.4. In this flow chart, human and organizational factors (HOF) play an important role in ensuring well control (barriers) and to act when well integrity is threatened. Early kick detection is a barrier of high importance, which failed in the *Deepwater Horizon* rig.

#### 11.1.4.4.1 Evacuation, Escape, and Rescue (EER) Experiences from Offshore Accidents

EER operations play a vital role in safeguarding the lives of personnel on board when a major hazard occurs on an installation. Based on previous accident reports, EER operations can be divided into three categories depending on the hazards, time pressure and RIFs (Skogdalen, 2011). This is shown in Figure 11.5.

When EER operations from the *Deepwater Horizon* rig was reviewed based on testimonies from the survivors, no casualties were reported as a result of the EER operations. However, those interviews offered unique insight into the level of success of EER operations. Testimonies revealed that several of the barriers on the *Deepwater Horizon* failed partially or totally. These systems included the general alarm, the blowout preventer, the emergency disconnect system (EDS) and the power supply. Several technical and non-technical improvements were suggested to improve EER operations (Skogdalen, 2011).

#### 11.1.4.4.2 The Perception and Comprehension of Safety

The perception and comprehension among offshore workers related to human, organizational and technical factors that influence safety barriers, is an important factor that's often measured through surveys. One element of safety culture is what has been called the safety climate, which is typically measured with surveys based on levels of agreement with predeveloped statements. Skogdalen and Tveiten (2011) reported that the perception and comprehension of safety differed significantly at Norwegian offshore installations between the offshore installation managers (OIMs), and the rest of the organization. The basis for the analysis was a safety climate survey answered by 6850 offshore petroleum employees in 2007. The OIMs had the most positive perceptions of the following categories of questions: safety prioritization, safety management and involvement, safety versus production, individual motivation and system comprehension. The article contributed to obtaining knowledge about the understanding of the safety climate at different levels of an offshore organization.

These findings were in line with previous studies that had originally reported that managers, who are closer to the planning and strategy of operations, express a more positive view of the safety level than others. Working offshore is special in the sense that all levels of the organization work, eat, have their time off and sleep in a very limited space far away from family. This creates a unique work environment in comparison to most other workplaces. Offshore workers often refer to the organization as one big family and state that there is a low level of hierarchy. It is thus of interest to see how this close interaction influences safety perceptions. Group

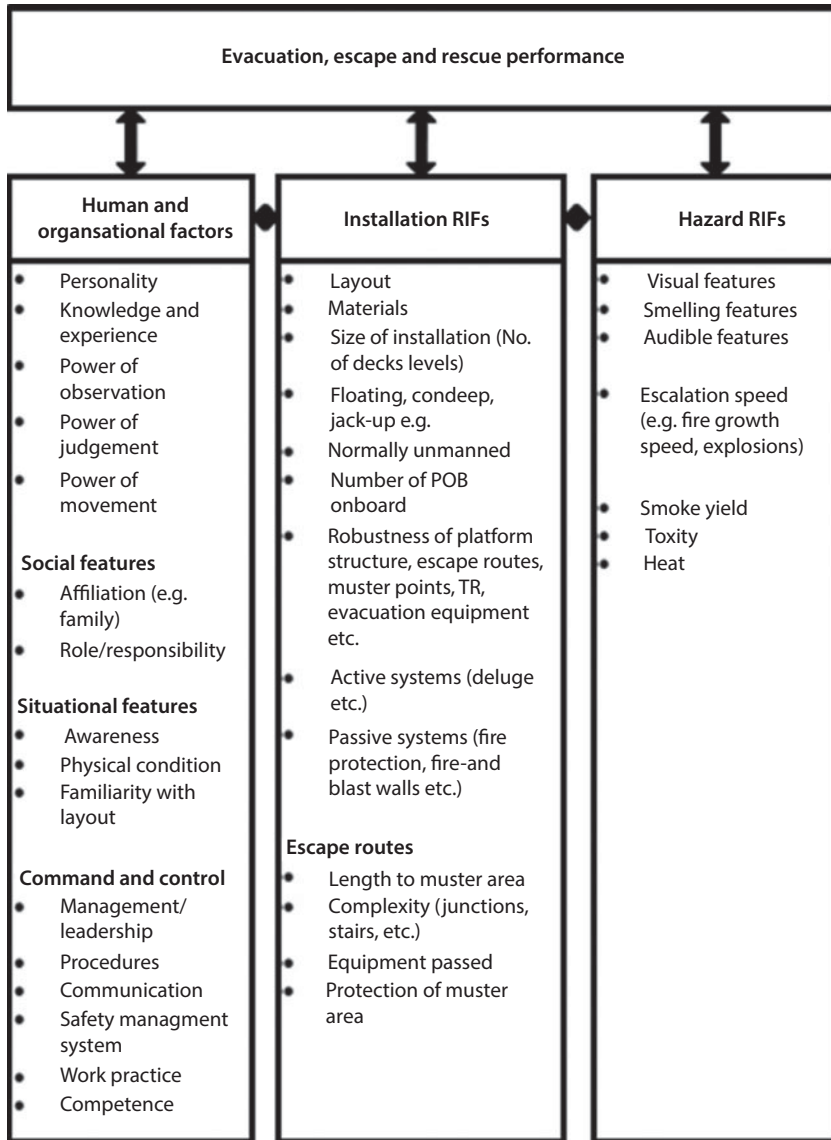

**Figure 11.5** EER performance (Skogdalen, 2011).

identity, different knowledge and control and issues of power and conflict may influence the different safety perceptions and comprehensions. The phenomenon of different safety perceptions and comprehensions between these groups is important to bear in mind when planning surveys as well as planning and implementing safety measures.

11.1.4.4.3 Indicators for Safety Barriers

The third subgoal for this thesis was to define indicators that are suitable for the measurement of barrier performance. The *Deepwater Horizon* accident was a result of failures in multiple barriers consisting of human, organizational and technical barrier elements. Barriers planned and included in design often degrade over time. Serious blowouts are rare events, and the rationale for many safeguards may be lost over time and the maintenance to keep them functional may not occur. Normalization of deviation, and a proper definition of deviation, is an important issue in this regard. Consequently, the first step when developing indicators is often to define what deviations are, and thereafter define how they should be monitored (Skogdalen *et al.*, 2011). The *Deepwater Horizon* accident shows that there is a need for more extensive monitoring and understanding of safety indicators. This requires a multidisciplinary approach and cooperation across the industry.

The Risk Level Project (RNNP) aims to monitor safety performance in the O&G industry on the Norwegian Shelf through the use of different statistical, engineering and social sciences methods (Skogdalen, 2011). The result is mainly summarized as safety indicators that contribute to the understanding of the causes of precursor incidents and accidents and their relative significances in the context of risk. As a tool, the RNNP has undergone substantial development since 1999/2000. This development has taken place in the context of collaboration between the partners in the industry, and a consensus that the chosen approach is a sensible and rational basis for a common understanding of the level of HSE and its trends from an industrial perspective (PSA, 2010c). More indicators related to

Well planning phase	Well drilling phase	Well control response due to precursor incident	
Indicators schedule and costs		Indicators well incidents	Indicators operator well response
Indicators Operational aspects (including well planning)			
	Indicators Technical condition of safety critical equipment		

Figure 11.6 Summary of suggested indicators related to deepwater drilling.

well incidents and well integrity can easily be added. Figure 11.4 summarizes the suggested indicators.

All the suggested areas for indicators are based on available data, which in several cases have been recorded for years by the regulatory authorities in Norway, research communities, companies and/or rigs. The data have not been used as the basis for indicators. Even though there seems to be agreement among the parties involved in the O&G industry that safety culture, operational aspects, technical conditions and the number of precursor incidents influence each other, there is a lack of understanding on how and why. This understanding can only be achieved by combining methods for risk management, such as different risk analysis methods, safety monitoring using indicators, the investigation of precursor incidents, revisions and inspections and accident investigations. In this way, a precursor incident, for example, a kick, will not only form the basis as an input into an indicator, but also its causes and follow-up actions can be used as the basis for indicators.

## 11.2 Case Studies

### 11.2.1 Effect of Drilling Fluid Discharge on Oceanic Organisms

Environmental effects of offshore petroleum operations have received much attention during the past several decades. Possible effects of discharges of drilling mud and cuttings and produced water from offshore facilities have been one subject of concern, and numerous field studies have been conducted to assess these effects as early as the early 1980s.

Bothe and Presley (1987) presented a case study involving a typical offshore petroleum well, for which 500–1000 tons (dry weight excluding cuttings) of drilling fluid solids were discharged into the sea.

In the Mississippi-Alabama-Florida (MAFLA) Rig Monitoring Study reported by the authors, concentrations of selected trace elements were determined in surficial sediments (0–2 cm) and macroporosity near an exploratory drilling site before, during, and after drilling. The site was located 19 km off Texas in the northwestern Gulf of Mexico (Figure 11.7).

A detailed summary of the study site is given in Table 11.1. This is one of only a few rig monitoring studies in which a complete, detailed record of drilling mud components discharged at the site was obtained. The influence of drilling activities on the sediments and organisms was assessed by determining levels of elements known to be major constituents of drilling muds (Ba, Cr, Fe) and of bioactive (Cd, Cu, Pb) and other trace elements (Ni, V)

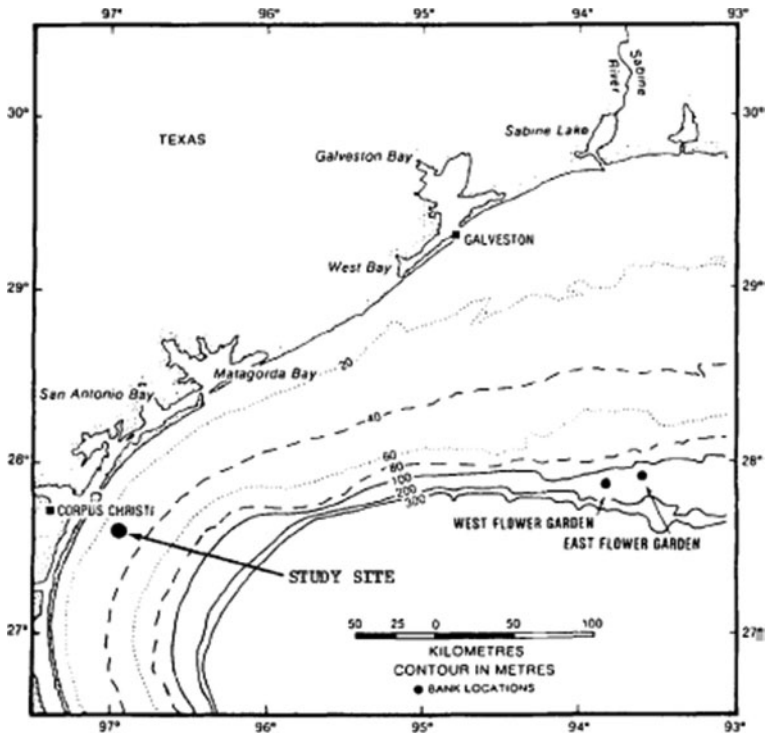

**Figure 11.7** Location of the exploratory drilling study site in the northwestern Gulf of Mexico ( $27 \sim 37^{\circ} 13.87''$  N,  $96 \sim 57^{\circ} 55.17''$  W in Mustang Island Lease Area, Block 792).

which may be released during drilling. They reported concentrations of selected trace elements present in drilling fluids (Ba, Cd, Cr, Cu, Fe, Pb, Ni, V) in surface sediments and macroepifauna around a Gulf of Mexico exploratory drilling site before, during, and after drilling operations. Observed significant increases in the levels of Fe in organisms and Ba and Cr in sediments were attributable to drilling discharges. Shrimp, which constitute the largest commercial fishery in the region, were intensively studied. Shrimp collected during the last few days of drilling had abdominal muscle iron concentrations more than twice those in shrimp sampled before or after drilling. Enhanced Fe solubility (bioavailability) in seawater, caused by soluble organic chelating agents in the drilling fluids, is the most likely explanation for the observed increases. Significant increases in sediment Ba were observed at all sampling radii but large increases (up to 7.5 fold) were only observed within a few hundred meters of the drilling site. An accurate mass balance of total discharged (excess) Ba present in sediments within 1000 m of the drilling site was determined. Only 9.3% of



**Table 11.1** Descriptive summary of study site, sampling regime, and drilling activities.

Item no. and description.	Information/data
<b>Site description (before drilling)<sup>a</sup></b>	
1. Water depth:	24 m
2. Sediment type:	Silty clay
3. Mean &cd li i k'] i l grain siije all station s (% dir nl);	
A. Sand	1.3 – 1.4 (0.5–7.9)
B. Silt	57.3 ± 13.3 (45–98)
C. Clay	45.0 ± 5.0 (31.6–51.5)
4 Mean sediment CaCQ, all s: a lions (ft d* -j:	3.9 ± 2.3 (0.5–9.3)
5. Mean sediment uigurnc carbon all station (% dw)	0.86 ± 0.09 (0.68–1.02)
<b>Sampling<sup>b</sup></b>	
6. Sampling dale*:	
A. Before drilling (organisnist/sedimeunn)	12-3-75/11-23 to 12-2-75
B. Dump drilling (ot^gs./seds.)	1-9 to 1-10-76/1-12 to 1-21-76
C. A fctr drill i ng (orgsJseds.)	3-26-76/3-28 to 4-2-76
7. Number of samples by type:	
A. lie fore drilling (orgsAccl-s)no. of suctions)	40/25/25
B. Dining drilling (orgs./scds}'nG, of stations}	40/24/24
C. After drilling (orgs./seds./nn. nf.stations)	73/25/25
<b>Drilling activity<sup>c</sup></b>	
8. Type (and nuniber) of wells:	Exploratorv (1)
9. Drilling period (dav-u drjUmgfdavi on site):	12-21-75 to 1-11-76 (13/20)
10. Total well depth (nn (and date reached):	2147 m (1-4-76)
11. Total volume of drill cutting (in1):	196 m <sup>3</sup>
12. lime between end <>t drilling and sampling.	
“Dur ng drilling’1 sampling phase (orgs./seds.)	In progress/1–10 d

(Continued)

Table 11.1 Cont.

Item no. and description.	Information/data
“After drilling” sampling phase (urgsVseds.)	74 d/76–81 d
Drilling mud components used (units 1000 kg dry wi.)	
13. Type of mud:	Lignosulfonate
14. Total weight of components used:	258
A. Barite (BaSO <sub>4</sub> ; weighting agent):	202 (73.2%)
B. Bentonite clay (native mineral; viscofier):	39.4 (15.3%)
C. Lignitic materia) (RD-1111 iltinner, dispenHnt)	7.5 (2.9%)
D. D Caustic soda (NaOH; alkalinity and pH control):	4.5 (1.7%)
E. Walnut hulls (lost circulation material):	1.6 (0.6%)
F. Lignosulfonate (thinner and dispersant):	1.1 (0.4%)
G. Lime (CaOH <sub>2</sub> ; alkalinity and pH control):	0.91 (0.4%)
H. Soda ash (Na <sub>2</sub> CO <sub>3</sub> ; calcium remover):	0.91 (0.4%)
I. Mica (native mineral: lost circulation material):	0.34 (0.1%)
J. Aluminum silicate (lost circulation material):	0.045 (<0.1%)

the total Ba used, and presumably other similar drilling mud components traced by Ba, was present within 1000 m at the conclusion of drilling. After 2.6 months, only 6.6% was present. Significant sediment resuspension and transport occurring in the high current nearshore study site (24 m water depth) was responsible for the low retention and rapid loss of discharged Ba in the sediment. The largest mean increase in sediment Cr (26%) occurred at the 1000 m sampling radii.

#### 11.2.1.1 Observations and Lessons Learned

With more than 100 t of Ba used, the significant changes in sediment Ba concentrations with time and distance observed in this study are clearly

attributable to the drilling activities. This study was the first to quantify the overall effect on barite dispersion. Comparison of total excess Ba data (TEB) from the "during" and "after" sampling phases suggests that the sediment transport process occurs rapidly. Over 29% of the excess sediment Ba is lost from the 2000-m-diameter study area during the 76 days between these samplings. This represents an average excess Ba removal rate of 11.5%/mo of the TEB initially deposited within the area. Data presented in this paper suggest that rapid Ba removal continues so that in less than 1 year only about 1% of the total Ba used is retained in sediments within 500m of the drilling site. This small percentage appears to persist in the sediments for at least 10 years.

To interpret the more subtle concentration trends observed for sediment Ni, Pb, and Cr is difficult. Had there been data on the background in absence of drilling fluid discharge, it would be appropriate to compare that set of data with the post-drilling data. However, that set of data was not available. However, an excellent data set was available from the mid-Atlantic exploratory rig monitoring study, in which a lignosulphonate type drilling mud, compositionally very similar to the mud in the 1987 study, was used. Using element/Ba ratios from the mid-Atlantic study, it was possible to estimate the amount of metals discharged during the drilling operation studied. The comparison of data suggests that the discharge of Ni and Pb during drilling could make a significant contribution to the inter-phase changes in sediment levels observed within 500 m of the site if all of the metals discharged remained in the area. On the basis of the behavior of Ba such large-scale, near-rig retention appears unlikely. The increases observed beyond 500 m represent amounts of excess metal 13–21 times greater than the estimated amounts discharged. It appears that drilling discharges can account for only a small portion of the observed increases in sediment Ni and Pb concentrations. This conclusion agrees with other monitoring studies which found no significant anomalies in Ni and Pb sediment levels attributable to exploratory drilling activities.

Drilling activities, which release large amounts of cuttings and clays, could be partially responsible for these changes. However, natural conditions at the site (i.e., strong currents causing sediment transport) were probably responsible for most of the changes observed.

In contrast, Cr discharged during drilling appears to result in significant increases in sediment Cr concentrations. The estimated discharge of Cr is sufficient to account for a large fraction of the observed increases out to 1000 m even without complete retention within the study area. The concentration increase in the 500–1000 m annulus is consistent for both post-drilling sampling phases and too large (26%) to be caused

by sediment texture changes not corrected by the Cr/Fe normalization procedure.

The discharged Cr appears to have been transported rapidly away from the rig, resulting in the observed negative correlation with distance. This trend is consistent with the fact that Cr is associated with the more soluble components of drilling muds, which would be expected to disperse differently than the denser, less soluble constituents traced by Ba. Although measurable, most of the increases in sediment Cr levels are small (<10%) and did not appear to cause elevated Cr levels in benthic organisms analyzed from the area.

The increase in muscle Fe concentrations is the only organismal trace element trend clearly attributable to drilling activities. The Fe elevation is large (100–159%), consistent, and highly significant for all species where such a comparison is possible (except *P. duorarum*, *S. empusa*). This fact suggests a significant, common exposure. Phase 2 organisms were collected 2–3 d prior to the departure of the drilling ship from the study site (Table 11.1). End of well discharges, comprising the heaviest and compositionally most complex drilling muds used at the site, were most likely occurring during this period. Cu is an active cofactor in the respiratory pigment (haemocyanin) of shrimp. Also, changes in Cu concentrations before and during drilling were not significant. These facts suggest that the physiology of the shrimp was generally constant among the three sampling phases, and thus the increase in Fe observed in the “during” sampling phase was caused by the drilling activities and not the result of some natural physiological variability among shrimp populations sampled.

### 11.2.2 Long-term Impact on Human Health

With increased awareness of long-term impact of petroleum operations, there has been a great number of publications on animals and humans affected by nearby drilling operations. Because of the potential for long-term effects of even low doses of environmental toxicants and the cumulative impact of exposures of multiple chemicals by multiple routes of exposure, the entire scope of sustainability has to be investigated (Khan and Islam, 2007). Bamberger *et al.* (2015) conducted a longitudinal study involving 21 cases from five states, with a follow-up period averaging 25 months. In addition to humans, this study involved food animals, companion animals and wildlife. More than half of all exposures were related to drilling and hydraulic fracturing operations; these decreased slightly over time. More than a third of all exposures were associated with wastewater, processing and production operations; these exposures increased slightly over time. Health impacts decreased for families and animals moving from intensively

drilled areas or remaining in areas where drilling activity decreased. In cases of families remaining in the same area and for which drilling activity either remained the same or increased, no change in health impacts was observed. Over the course of the study, the distribution of symptoms was unchanged for humans and companion animals, but in food animals, reproductive problems decreased and both respiratory and growth problems increased. This longitudinal case study illustrates the importance of obtaining detailed epidemiological data on the long-term health effects of multiple chemical exposures and multiple routes of exposure that are characteristic of the environmental impacts of unconventional drilling operations.

In this study, unconventional wells were represented in the majority of cases (19/21). Three cases had more than one type of well. In three cases, people living nearby unconventional gas extraction at the time of the first interview moved to areas with no or very little industrial activity by the time of the second interview, and in one case, the move occurred prior to the first interview; all data listed for this particular case under first interview pertain to the location before the move. In all four cases where people moved, the animals moved with the people except in one case, where a manager of a horse-breeding farm relocated with her dog, but the horses used for breeding remained at the location of the first interview.

Within 3 months after the second interview, another case participant moved to an area with no or very little industrial activity; as this move occurred after the second interview, this case is not included with the four cases that have moved by the time of the second interview. In all cases, people are planning to move or would like to move if financially feasible.

Table 11.2 lists the sources of exposure and the number of cases with each exposure determined up to and including the time of the first interview and the number of cases with each exposure determined after the first interview and up to and including the time of the second interview. All cases had more than one type of exposure. In cases where people had moved by the time of the second interview, exposures were based on the most current location. In the case of the horse-breeding operation mentioned above, exposures were determined for two different locations at the time of the second interview: one location for the manager and her own animals, and another location for the horses that remained on the farm. In cases where surface contamination occurred and remediation was either not attempted or failed, exposures remained the same. More than half of all exposures were related to drilling and hydraulic fracturing operations, and these decreased slightly over time. More than a third of all exposures were associated with wastewater and processing and production operations, and these exposures increased slightly over time.

**Table 11.2** Sources of exposure and the number of cases with each exposure.

Sources of exposure	Number of cases	
	First interview	Second interview
Drilling/Hydraulic Fracturing		
Well/Spring water	16	17
Municipal water	1	1
Pond/Creek water	13	5
Drilling fluids and muds pit leak/spill	3	1
Drilling fluids and mud blowout	1	1
Drilling get spilled into creek	1	0
Storm water run-off from well pad to property	2	1
Hydraulic fracturing fluid spill from holding tank	1	1
Casing failure	3	3
Flaring	9	9
Venting	2	1
Wastewater	–	–
Wastewater impoundment leak	3	2
Wastewater spread on road	3	3
Wastewater dumping into property	1	2
Wastewater dumping into waterway	2	4
Wastewater impoundment not contained	4	3
Wastewater impoundment liner fire	1	0
Wastewater spills during transfer, truck accidents, valve left open	0	1
Storm water runoff from impoundment to property	0	1
Misting via aerators	3	1
Septic impoundment	3	0
Processing and Production	–	–
Pipeline leak/rupture	2	1
Pipeline explosion	0	1
Compressor station malfunction	2	2

*(Continued)*

**Table 11.2** Cont.

Sources of exposure	Number of cases	
	First interview	Second interview
Compressor station emissions	0	1
Flaring of methane during oil production	1	1
Condensate tanks leak/rupture	2	1
Condensate tanks venting	1	1
Wellhead venting	2	3
Venting of methane during oil production	1	1
Condensate fluid dumping into waterway	1	1
Heater-treated malfunction	1	1

In the four cases where people moved to areas with no or very little oil or gas industrial activity, there was no reported air or water contamination. Most of the cases that have not moved (14/17) have experienced both air and water contamination, and nearly all (16/17) of cases that have not moved use alternative sources of water for drinking for themselves and their small animals. These sources include bottled water, filtered water or hauled water. Many owners of food animals (cattle, goats, chickens) and large companion animals (horses, goats and large breeds of dogs) were often forced to offer their animals contaminated water as they were not provided with a water buffalo or could not afford one. Approximately half of these cases also use alternative sources of water for bathing themselves and their animals, washing clothes and dishes, and all other uses except for flushing the toilet. Of cases with air contamination (14/17), only two are currently using air filters. All cases with air contamination report keeping windows shut as often as possible, keeping children and small animals inside and staying away from home as much as possible.

Figure 11.8 depicts how health changed over time for humans, companion animals and food animals. The significance was tested with a chi-square analysis. Specific symptoms were reported in all health categories, but only health categories with the most commonly reported symptoms are shown. Seventeen animals (song birds, raptors and game fish) were impacted in three cases at the time of the first interview. In one case, the family moved, and there is no information on wildlife numbers at the first location; in the other two cases, wildlife numbers have rebounded coincident with a decrease in industrial activity.

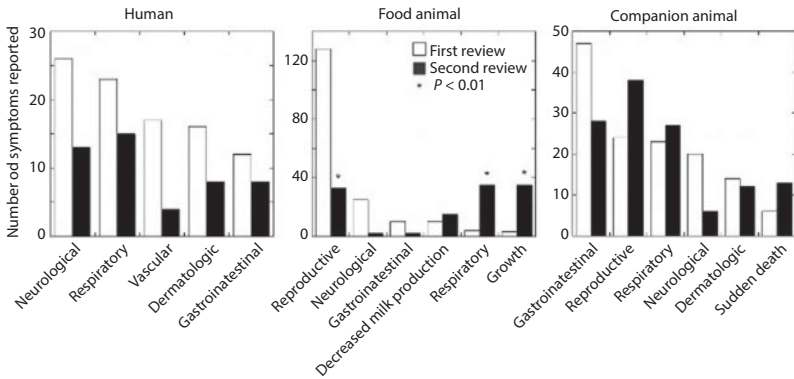
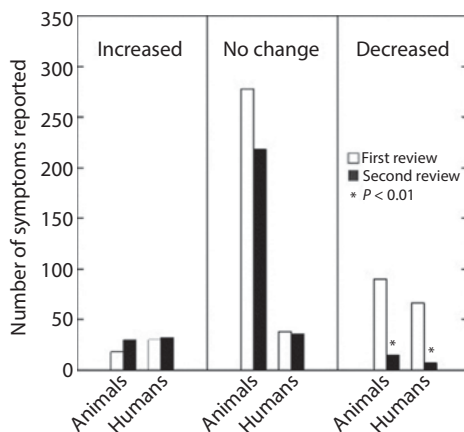

**Figure 11.8** Number of symptoms reported for various classes of health impacts reported in the first and second interviews for humans, food animals and companion animals.

In people, the most common health impacts at the time of the interviews fell under the categories of neurological, respiratory, vascular, dermatologic, and gastrointestinal problems; there were no significant changes in health over time. In companion animals, the most common health impacts at the time of the interviews fell under the categories of gastrointestinal, reproductive, respiratory, neurologic, and dermatologic problems, and sudden death; as in humans, no significant changes in health were noted over time. In food animals, the most common health impacts at the time of the interviews fell under the categories of reproductive, neurologic, gastrointestinal, decrease in milk production, respiratory, and growth problems; significant changes in numbers of reported symptoms were noted over time in the categories of reproduction (decrease), respiratory (increase) and growth (increase) problems.

The initial spike in reproductive problems in food animals occurred because several herds were exposed directly to drilling muds and fluids, fracturing fluids or wastewater; over time, these incidents decreased. However, farmers in these cases are still reporting increased reproductive problems above what they have seen in their many years of raising cattle, especially on farms where the entire herd was exposed. Respiratory symptoms in food animals increased from the first to the second interviews; this may in part be due to the slight increase over time in exposures to processing and production operations and the fact that food animals are often on site for long periods and thus have high exposure rates. Growth problems also increased over time in food animals and may potentially have many causes, but when associated with fossil fuel operations, may be indicative





**Figure 11.9** Number of symptoms reported for humans and animals in the first and second interviews categorized by cases where drilling activity had increased, cases where it remained the same, and cases where it had decreased.

of exposure to endocrine disruptors (Colborn *et al.*, 2011; Kassotis *et al.*, 2014; Colborn *et al.*, 2014).

Figure 11.9 represents the total number of reported health symptoms for humans or animals living in areas where the activity was divided into these three categories. The category of decreased activity included families who had moved away from their original location to areas with little or no drilling activity. The level of industrial activity was determined through several sources: case participants, state environmental regulatory agencies, community science groups, independent researchers and documentation of incidents by case participants and neighbors. In three cases, industrial activity increased over time; no significant health changes were noted in either humans or animals. In nine cases, industrial activity remained the same over the course of this study, and there were no significant changes in the total number of reported symptoms over time. In ten cases, where industrial activity decreased over time, the total number of reported symptoms in humans and animals also decreased.

The major finding of this study is that health impacts dropped for families and animals moving out of intensively drilled areas or remaining in areas where drilling activity decreased. In the cases of families that remained in the same area and for which drilling activity either remained the same or increased, no change in health impacts was observed. This is particularly interesting because, in some of the cases, the initial interview was done after an incident, such as a wastewater leak from an impoundment.

The distribution of symptoms was unchanged for humans and companion animals, but was significantly changed for food animals. Reports of reproductive failure fell, while respiratory issues and stunted growth were reported more often. Although this may be a consequence of the selection of cases, it represents an interesting change. In some of the cases involving food animals, the initial interview was conducted following an incident such as the leak of wastewater into a pasture or into the source of drinking water for the herd. These incidents were strongly associated with the failure to breed. In the second interview, the contaminated areas were made inaccessible or remediated; in one case, the herd was provided an alternative source of water.

#### 11.2.2.1 *Lessons Learned*

Because of the complexities of multiple exposure pathways, multiple possible chemical toxicants, multiple sources of contamination, and changes in toxicant concentration over time, direct measurement of chemical contamination is problematic. For these reasons, studying the health effects of humans and animals living near gas and oil drilling and processing facilities provides a more direct measure not only because health consequences represent the actual variables of interest but also because they reflect the integration of toxic insult over time and multiple exposure pathways. The impact of drilling on human health is a complex topic and there is a need to have extensive analytical measures of the prevalence of health problems among humans, companion animals and food animals in areas of gas and oil extraction. It is also understood that sustainable drilling projects must involve natural materials that have time-honoured compatibility with the ecosystem.

### 11.3 Summary

Safety and environmental issues dominate key aspects of a drilling project. Both short-term and long-term impacts of drilling operations are presented. Even though progress has been made in dealing with short-term consequences, little is known on the long-term impacts. More research is needed for assessing the environmental impacts prior to rendering the drilling process sustainable.

### References

Aadnoy, B.S. and Saetre, R., 2003, New model improves deepwater fracture gradient values off Norway, *Oil and Gas Journal*, Feb. 3.

- Aadnoy, B.S. and Looyeh, R. 2011. *Petroleum Rock Mechanics: Drilling Operations and Well Design*, first edition. Oxford: Gulf Professional Publishing.
- Bakhtyar S and Gagnon M M 2012 Toxicity assessment of individual ingredients of synthetic-based drilling muds (SBMs), *Environmental monitoring and assessment* 184(9) 28–37.
- Bakke, T., Klungsoyr, J., and Sannic, S., 2013, Environmental impacts of produced water and drilling waste discharges from the Norwegian offshore petroleum industry, *Marine Environmental Research*, Volume 92, December 2013, Pages 154–169.
- Bamberger, M. & Robert E. Oswald, R.E., 2015, Long-term impacts of unconventional drilling operations on human and animal health, *Journal of Environmental Science and Health, Part A*
- Boothe, P.N., and Presley, B.J., 1987, The Effects of Exploratory Petroleum Drilling in the Northwest Gulf of Mexico on Trace Metal Concentrations in Near Rig Sediments and Organisms, *Environ Geol Water Sci.*, Vol. 9, No. 3, 173–182.
- Boothe, P.N., and Presley, B.J., 1987, The effects of exploratory petroleum drilling in the northwest gulf of mexico on trace metal concentrations in near rig sediments and organisms, *Environmental Geology and Water Sciences* October 1987, Volume 9, Issue 3, pp 173–182.
- BP, 2017, BP Statistical Energy Review, June.
- Breuer, E., Stevenson, A.G., Howe, J.A., Carroll, J., Shimmield, G.B., 2004. Drill cutting accumulations in the Northern and Central North Sea: a review of environmental interactions and chemical fate. *Mar. Pollut. Bull.* 48, 12e25.
- Colborn, T.; Kwiatkowski, C.; Schultz, K.; Bachran, M., 2011, Natural gas operations from a public health perspective. *Inter. J. Human Ecol. Risk Assess.* 17, 1039–1056.
- Colborn, T.; Schultz, K.; Herrick, L.; Kwiatkowski, C., 2014, An exploratory study of air quality near natural gas operations. *Hum. Ecol. Risk Assess.* 20, 86–105.
- Dusseault, M.B., 2011, Geomechanical Challenges in Petroleum Reservoir Exploitation, *KSCE Journal of Civil Engineering*, 15(4):669–678.
- EPA, 2016, How Did the Environmental Justice Movement Arise? Available at <https://www.epa.gov/environmentaljustice/environmental-justice-timeline>
- EPA, 2016, Oil and Gas Extraction Effluent Guidelines and Standards (40 CFR Part 435), original in 1979, modified in 2016.
- GESAMP, 1996, *The contributions of science to integrated coastal management*, GESAMP Reports and Studies No. 61, available at <http://www.fao.org/3/contents/dc824e26-b1b7-568d-8770-1f9347ecb063/W1639E00.HTM>
- Gobo, A.E., Richard, G., and Ubong, I.U.J., 2009, “Health Impact of Gas Flares on Igwuruta/Umuechem Communities in Rivers State,” *Applied Science & Environmental Management*, Vol. 13, No. 3, pp. 27–33.
- International Energy Agency (IEA), 2017, *World Energy Outlook 2017*, 782 pages, ISBN Print: 978-92-64-28205-6 / PDF: 978-92-64-28230-8.

- Islam, M.R., Wei, D., and Balash, P., 2017, "Editor Editorial of Special Issue on Energy Economics", *Journal of Sustainable Energy Engineering*, vol. 5, issue 4, 243–245.
- Ismail, O.S. and Umukoro, G.E., 2012, Global Impact of Gas Flaring, *Energy and Power Engineering*, 4, 290–302.
- Kassotis, C.D.; Tillitt, D.E.; Wade Davis, J.; Hormann, A.M.; Nagel, S.C., 2014, Estrogen and androgen receptor activities of hydraulic fracturing chemicals and surface and ground water in a drilling-dense region. *Endocrinology*, 155(3), 897–907.
- Khan, M.I. and Islam, M.R., 2007, *True Sustainability in Technological Development and Natural Resource Management*, Nova Science Publishers, NY, 381 pp.
- Khan, M.M. and M.R. Islam, 2016, *Zero-Waste Engineering: The era of inherent sustainability*, 2<sup>nd</sup> Edition, John Wiley & Sons, Inc. Hoboken, New Jersey, and Scrivener Publishing LLC, Salem, Massachusetts, USA, 660 pp.
- Mitchell, R.F. (ed.), 2007, *Petroleum Engineering Handbook, Volume II: Drilling Engineering*, SPE, 763 pp.
- Moreau, R., 2009, Nautical activities: what impact on the environment? Report for European confederation of nautical industries – ECNI, June.
- Myrzagaliev S A and Zaytsev V F 2012 Environmental assessment during drilling operations on oil-gas fields, *SOCAR Proceedings* 4 63–67.
- Norwegian Oil and Gas, 2013, Norwegian Oil and Gas Environmental Report 2013, The Norwegian Oil and Gas Association (2013), available at <http://www.norskoljeoggass.no/en/Publica/Environmental-reports/Environmental-report-2013/>
- OSPAR Commission, 2000, OSPAR Decision 2000/3 on the Use of Organic-phase Drilling Fluids (OPF) and the Discharge of OPF-contaminated Cuttings (2000), OSPAR 00/20/1-E, Annex 18.
- OSPAR Commission, 2012, OSPAR List of Substances Used and Discharged Offshore Which Are Considered to Pose Little or No Risk to the Environment (PLONOR) (2012), OSPAR Agreement 2012–06.
- Shkitsa L.Y. and Yatsyshyn T.M. 2012 State environmental safety of the drilling rig territory depending in the intensity of the mud evaporation, *Modeling and Information Technology* 65 10–16.
- Shkitsa L.Y. and Yatsyshyn T.M. 2014 Increased environmental safety pump circulation system of the drilling rig, *Exploration and development of oil and gas fields* 3(52) 7–16.
- Skogdalen, J.E., 2011, Risk management in the oil and gas industry Integration of human, organisational and technical factors, PhD Dissertation, University of Stavanger, Norway.
- Skogdalen, J.E., Tveiten, C., 2011, Safety perceptions and comprehensions among offshore installation managers on the Norwegian Continental Shelf. *Journal of Safety Science*.
- Skogdalen, J.E., Utne, I.B., Vinnem, J.E., 2011, Developing safety indicators for preventing offshore oil and gas deepwater drilling blowouts. *Safety Science*, 49: 1187–1199.

- Turner, K.P., 2002, Bioremediation of drill cuttings from oil based muds, PhD Dissertation, University of Nottingham, U.K.
- Wærnes, K., 2013, Applying Dual Gradient Drilling in complex wells, challenges and benefits, MSc Thesis, Faculty of Science and Technology, University of Stavanger, Norway.
- Yousif K. Kharaka and Nancy S. Dorsey, 2005, Environmental issues of petroleum exploration and production: Introduction, *Environmental Geosciences*, v. 12, no. 2, June pp. 61–63.
- Zhang, S., 2014, Petroleum geomechanics characterization using coupled numerical modeling and soft computing, PhD dissertation, Department of Chemical and Petroleum Engineering, University of Wyoming, Laramie, USA.

# 12

## Summary and Conclusions

### 12.1 Summary

The drilling practice in the oil and gas industry is directly proportional with sustainability (i.e., economically attractive, environmentally appealing, technically sound, and socially responsible). Even if a small problem is encountered at any stage during drilling, such an event will result in an economic loss (i.e., economical, and time factor) and may bring about a threat to sustainability. This book is based on the study of all these problems often encountered during drilling and ways to apply practical solutions to those problems. In this advanced technological and information age, drilling practices have been at the cutting-edge level but the problems are still of the same nature, such as borehole instability, loss-circulation, stuck pipe, gas cuts in a shallow formation, salt dome, kick, blowout, and back flow, etc. This book covers all problems, both of natural and man-made origins. In addition, the book identifies whether the problem is due to human error or to the improper handling of the tool during the drilling operations. It is well recognized that these issues are critical regarding the time factor and also a company's budget allocation. Therefore, if these problems occur

during drilling, then the possible remedial actions in order to save the time factor as well as the economics are kept and handled accordingly. In every chapter, this book offers remedial actions, including the solutions of the problems, which involve proper design of drilling components regarding given geophysical data of formation, proper usage of drilling fluid to avoid bit balling, formation sloughing, maintaining hydrostatic pressure and proper usage of blowout preventer to control abnormal pressures and so on. These types of actions lead to a superior drilling performances that may be considered as a benchmark in the petroleum industry.

The book rebuilds the notion that there is a need to develop an innovative drilling system, which will have the potential to revolutionize the whole drilling process or in any stage of drilling operations. As such it introduces case studies in each chapter. It shows that case studies themselves manifest overall thrust on innovative solutions. In addition, continuous research and development (R&D) in this area is crucial to have a significant impact on drilling success, reducing time, and overall cost saving. Such systems are increasingly necessary to overcome the drilling challenges by small, elusive, easily damaged subsurface targets. This is particularly true in applications where identification of small or difficult-to-predict drilling targets and formation damage are key issues in drilling success.

Petroleum resources are major players of modern civilization and drilling operations rebuild the most important component of the petroleum industry. However, drilling engineering has numerous problems and their solutions are challenging. This book is designed to guide the engineers, operators in solving prospective problems encountered during drilling operations. Of course, the list of problems is not exhaustive but the science established in solving the problem is comprehensive, thereby allowing operators to draw upon personal experiences and use this book as a guideline.

## **12.2 Conclusions**

Based on various chapters presented, the following conclusions can be reached for different chapters.

### **12.2.1 Chapter 1: Introduction**

Chapter 1 introduces the fundamental aspects of the drilling problems faced by the drilling operators, drillers, crews, and related professionals in

general. It identifies the key areas, for which drilling problems are encountered, along with their root causes. Often, one problem triggers another problem and snowballing of problems occurs, thus incapacitating the drilling process. In this process, there is no 'small' or 'large' problem, as all problems are intricately linked to each other, eventually putting safety and environmental integrity in jeopardy. The key conclusions of this chapter are:

1. Every problem encountered opens up an opportunity for solving the problem in future and improving the drilling practices.
2. Every case study dealing with problems and solutions thereof presents the readership with a clear understanding of the process and enriches the learning experience with expert knowledge of field problems and solutions.
3. This process knowledge gathering will create a culture of preventative measures and ultimately lead to sustainable developments.
4. Lessons learned from failures offer a far superior opportunity to gain insight than commonly touted success stories.

### **12.2.2 Chapter 2: Problems Associated with Drilling Operations**

This chapter presents problems that are broad in scope either by virtue of the natural properties of the rock/fluid system or type of drilling being performed. Included is the discussion of remedial solutions to the hazards offered during drilling of a formation containing  $H_2S$ , shallow gas formations, and equipment and personnel-related problems. Major drilling problems and their solutions related to drilling rig and operations are discussed and case studies presented. Based on this discussion, the following conclusions can be reached:

1. Drilling through  $H_2S$  bearing zone has to be carefully planned ahead and as much geological data gathered as possible. The entire safety procedure should be rehearsed and contingency plans chalked out.
2. Reservoir characterization of shallow gas formations should be performed in order to maximize the knowledge of the formation. Dynamic analysis should be performed as new drilling data become available.



3. In difficult/hazardous formations, a pilot hole should be drilled in areas with possible shallow gas, because the small hole size will facilitate a dynamic well killing operation.
4. Shallow kick-offs should be avoided in areas with probable shallow gas. Top hole drilling operations in these areas should be simple and quick to minimize possible hole problems. BHAs used for kick-off operations also have flow restrictions which will reduce the maximum possible flow through the drillstring considerably.
5. Proper monitoring and recording systems that monitor trend changes in all drilling parameters should be in place.
6. Whenever an incident occurs, on-site diagnosis must be performed and causes of the incident identified prior to executing a remedial action.
7. ROP should be optimized depending on the terrain being drilled through. Often, a low ROP has to be tolerated in exchange of safe drilling.
8. For every incident, a repertoire of difficulties should be constructed. It can become a valuable guidance tool for future operations in nearby sites.

### 12.2.3 Chapter 3: Problems Related to the Mud System

Great advances have been made in the areas of mud system. Consequently, associated problems have been reduced significantly. However, the innovative solutions have come at the expense of the introduction of new generations of chemicals that are not necessarily less toxic, even though they all pass the regulatory requirements. In addition, mud engineering under difficult drilling scenarios continues to be a great challenge. In addition, failure to select and formulate the mud correctly will create many problems. This chapter attempts to include all drilling problems and their solutions related to drilling mud and its system only. The different problems while drilling are explained in addition to their possible solutions, preventions, along with case studies. Based on the discussion provided in this chapter, the following conclusions can be reached.

1. Many new-generation mud systems involve smart materials, including some that introduced lost circulation prevention chemicals within the mud system. These chemicals are effective but often expensive and more importantly their long-term impact has not been researched adequately.

- Caution must be taken in employing these materials and research should continue to develop a new generation of mud systems that are readily acceptable by the eco system.
2. Formation damage can be minimized by correctly designing a mud system and with the adoption of dynamic features that include latest reservoir data collected through analysis of cuttings.
  3. The complete prevention of lost circulation is impossible because some formations, such as inherently fractured, cavernous, or high-permeability zones, are not avoidable when encountered during the drilling operation if the target zone is to be reached. However, dynamic adjustments in drilling fluid properties can minimize lost circulation. In any case, contingency plans must be in place in case vulnerable sites are known.
  4. Prevention measures for lost circulation include (i) crew training on 'reading' drilling data, (ii) maintenance of proper mud weight, (iii) minimize annular friction pressure losses during drilling and tripping in, (iv) maintain adequate hole cleaning and avoid restrictions in the annular space, (v) set casing to protect weaker formations within a transition zone, (vi) updating formation pore pressure and fracture gradients for better accuracy with log and drilling data, and (vii) study wells in area where to be drilled. The thumb rule is that if anticipated, treat mud with lost circulation materials.
  5. Preventative measures are the most suitable for combating formation damage.
  6. Oil-based muds should be considered for both zones vulnerable to formation damage and salt formations.
  7. In case oil-based mud is not a feasible option, low solids polymers and balanced salt concentration of the water-based mud should be considered.
  8. Many new hole cleaning techniques have surfaced over last few decades, for both vertical and horizontal wells. An appropriate removal technique custom designed for specific need of the wellbore must be selected. For instance, technique would be different for vertical section, slanted section, or horizontal section of the well.
  9. Ultrasonic irradiation for removal of mud cake is a relatively new technique, but has good potential.

### 12.2.4 Chapter 4: Problem Related to Drilling Hydraulics

The drilling hydraulics plays the role of an engine. As such, any problem in the smooth operation of the hydraulic system would snowball and may be manifested through a far more complex problem than the original one. It is well known that regular maintenance of the hydraulic system can be helpful in preempting long-lasting problems that might take place. In this process, factors that are important to consider are: (i) duration of the rig operating per day and per week, (ii) percentage of time that the system is operating at maximum flow and pressure, (iii) environmental and climatic conditions, including extreme heat, cold, wind, presence of debris and dust, humidity, (iv) properties of fluids that are being used (in form of mud, spacers, cement, etc.), (v) rate of penetration (ROP), and (vi) rock properties. Based on the discussion of this chapter, the following conclusions can be made:

1. The drillstring is inherently vulnerable to failure that can be triggered through sustained exposure to stresses, including tension, compression, bending, and twisting in the wellbore due to complex geological conditions of the drilled formations. While the level of stresses can be different for different formations, every formation has the ability to invoke failure due to the nature of the drilling operation.
2. The use of air drilling, poor quality of drillstrings (including manufacturing defects), or electrochemical deterioration (in presence of corrosive material) of the tubulars can lead to hydraulic system failure.
3. In case the drillstring is stuck, improper maneuvering, such as over pulling and over pushing of drillstring, may result in fatigue or rupture of drillstring due to the extra-large tensile or compressive stress acting on drillstring. Such maneuvering must be avoided.
4. Borehole instability as well as improper sizing of the wellbore is often related to the hydraulic system in addition to obvious mud density and other rock/fluid parameters.
5. Problems such as fracturing, hole collapse, and trajectory deviation are intricately related to the hydraulic system.
6. Maintaining desired flow regime in both the drillpipe and the annulus is the most important function of the hydraulic system. Such regimes should be predetermined and frequently checked in order to ensure proper flow regime is active.

### 12.2.5 Chapter 5: Well Control and BOP Problems

A drilling operation is inherently unstable because it involves creating instability in the natural rock/fluid system. The most crucial component of drilling in terms of safety is the well control. Any loss of control can lead to disastrous outcome both in the short term and the long term. The well control system involves the technology to control the fluid invasion and to maintain a balance between borehole pressure (i.e., pressure exerted by the mud column in the wellbore) and formation pressure (i.e., pressure in the pore space of the formation) for preventing or directing the flow of formation fluids into the wellbore. In order to maintain control, the monitoring system must be in sync with the BOP system, along with a well-trained crew who can remedy any malfunction in the overall process by using real intelligence. Based on the discussion presented in this chapter, the following conclusions can be made.

1. Detection and early remediation of kicks is the key to well control and prevention of blowout or major incident involving a drilling operation.
2. Subsea kick detection is pivotal and gives information regarding troubling incidents to come.
3. It is important to monitor early signals of a kick. In order to do that, it is important to have a benchmark present. Often a standard or benchmark is absent from a drilling operation and little attention is paid to the normal operations and various parameters until an incident takes place. A routine maintenance operation and continuous monitoring of all data along with real-time analysis is key to smooth operation of a drilling project.
4. A blow is always preceded by warning signals. An experienced crew should analyze the monitoring data and remedy any deficiency in the control system before the well goes out of control. Any solution offered must be after detection of the cause of the anomalous behavior.
5. Primary indicators, such as, flow rate increase, pit volume increase, flowing well with pump shut off, and improper hole fill-up during trips must be reported and analyzed immediately.
6. Secondary indicators, such as, changes in pump pressure, drilling break, gas, oil, or water-cut mud, and reduction in drillpipe weight have the advantage of giving a leeway to the

decision makers as the outcome is not immediate. However, it is more difficult to find the root cause of anomalies in the secondary indicators as the process is often convoluted. The development of a comprehensive diagnostic tool for determining the root cause is still a research project and a commercial status is years away.

7. Blowout can happen during any of the operational phases, namely, drilling, well testing, well completion, production, and workover. For each phase, a complete plan of maintenance, remedy, contingency plan, and personnel training must in place and rehearsed before and during the drilling operation.
8. Every item concerning well control must take in consideration of the specific nature of each drilling site. If it is a wild cat, extra precautions must be taken and efforts must be made to maximize accuracy of characterization of the formation, based on geology and geophysical data. Also, as the drilling progresses, data collected should be analyzed in real time, continuously refining the subsurface model.
9. At no time should a new additive be allowed to be injected without prior scaled model studies, including modeling under realistic field conditions. Also, an offshore well is not a candidate for testing new products, either as an additive to the mud system or to cement.
10. Underbalance drilling can be in practice only if the prevailing conditions are well known and preventive measures are all in place and well functioning.
11. If abnormal pressure conditions or extreme heterogeneity (including pressure pockets) exist, extra precautions must be taken in the planning of the drilling project.
12. Research should be an integral part of any control operation, even when a well is being restored from an event of blowout.

### **12.2.6 Chapter 6: Drillstring and Bottomhole Assembly Problems**

Every drilling activity is unique and as such requires custom-designed attention to the bottomhole assembly (BHA), which is typically the most flexible component of the overall drillstring. How BHA is organized will dictate how the well will perform. Many potential problems can be averted by selecting adequate BHA and other components, such as stabilizers, drill

collar, bit sub, jarring devices (called “jars”), sonic-while-drilling tools, logging-while-drilling, directional drilling equipment, etc. Proper selection will also ensure achieving desired trajectory, optimizing ROP, and minimizing vibration-related stress. Based on the discussion presented in Chapter 6, the following conclusions can be reached.

1. The most common problem of drillstring-related issues is the event of stuckpipes. It is important to locate the point of pipesticking as well as the causes of such events. The currently used methods for determining the location of the stuckpipe are adequate but can be rendered more useful if both methods are used to improve accuracy.
2. Causes of the stuckpipe problem often gives a clue as to how to remedy most effectively and how to proceed in following up without recurrence of the event. Causes of stuckpipe are often related to lithology of the formation and therefore must be shared with the onsite Geologist, who should conduct real-time analysis with the latest available drilling data.
3. Differential sticking can occur because of one or more of the following reasons:
  - a. A permeable formation
  - b. Thick filter cake
  - c. The drillstring is in contact with that filter cake
  - d. An overbalance situation exists
  - e. Insufficient drillstring movement
  - f. A lack of circulation between the drillstring and the filter cake.

Research conducted for specific applications must be considered to first free the drillstring, then to continue trouble-free operation.

4. Geopressed formations, reactive formations, unconsolidated formations, mobile formations or fractured/faulted formations require special considerations for design of the drillstring.
5. Vibrations should be minimized and routine checkup made on the status of fatigue of the drillstring. Recently developed Frank’s Harmonic Isolation (HI) tool is reported to produce effective control of vibrations. The HI Tool® is an on-bottom drilling tool, designed to reduce vibrational loads generated by drill bit dynamics.

6. Commercially available anti stick-slip tools (AST) are effective in preventing stick-slip vibrations produced in the process of cutting through problematic underground formations. Data collected through these tools can become valuable in real-time characterization of the formation that is being drilled.
7. Rate of penetration (ROP) can be maximized through optimization of underbalance drilling, hydraulic ultra-high pressure (UHP) jet assisted downhole drilling, novel cutting-cleaning techniques, incorporation of real-time monitoring and guidance tools.
8. Dynamic measurements and real-time analysis of downhole weight can lead to successful prediction of many drillstring-related problems. Real-time updating and intervention by an experienced dedicated on-site engineer are crucial to solving such problems.

### 12.2.7 Chapter 7: Casing Problems

The casing system is the backbone of the well integrity. Any failure of the casing system can turn the drilling process into a failure as evidenced in the 2010 *Deepwater Horizon* disaster. Many problems emerge from casing problems. Based on the discussion presented in this chapter, the following conclusions can be made:

1. When casing jam occurs during installment, it must not be forced down, otherwise screen deformation or casing buckling will occur. Instead, preemptive measures such as minimizing pull down pressure while drilling, increasing annular space, etc., should be used.
2. Buckling should be avoided in drilling operations to minimize casing wear and potential drilltime loss. Buckling can be reduced or eliminated with the following procedures:
  - a. Applying a pickup force when landing the casing in surface wellhead after cement set
  - b. Holding pressure while wait on cement (WOC) to subject the string to tension
  - c. Raising the top of cement
  - d. Using centralizers to increasing casing bending stiffness.
3. Surface casing plays a crucial role, the effects of which can hamper subsequent drilling operations. Conventional

surface casing design calculations suffer from a number of assumptions that restrict the nature of soil being drilled. For instance, if a weaker formation exists below the casing shoe, a blowout may occur. The competency of the surface casing shoe is the single most important parameter in preventing a fracture to surface – a factor that will remain important throughout the life of the well.

4. In order to decide on the setting depth of casings, protection of fresh water aquifers, lost circulation zones, salt beds and low pressure zones must be considered. When the setting depth based on mud weight is found, the kick criterion has to be considered.
5. Case studies show clearly that the more data available, the smaller the uncertainty and the better is the decision regarding casing placement. If all data are not considered and integrated, casing problems would occur during drilling or afterwards.
6. Case studies reveal that Sustained casing pressure (SCP) situations occur because of fluid migration between casing layers due to improper conversion between TOC and the previous casing shoe setting depth. A higher cement column or deeper the casing shoe placement may have averted many SCP situations.
7. The following factors play a role in rendering casing cement ineffective.
  - a. The required height of the cement column creates too large pressure on the formation surrounding the casing shoe.
  - b. Annulus is too tight, thus making it impossible to squeeze cement into the small space.
  - c. Cement may break down the formation.
8. Often so-called cement blocks occur when dislodged cement blocks accumulate within the bottomhole and jam against the drillstring. This dislodgment can be caused by large-sized collars and stabilizers that can break loose blocks of cement after the cement has been set and leak off test been completed. This phenomenon is harmful to both casing integrity and cementing and can be prevented through the following measures.
  - a. Minimizing the length of the rat hole below the casing shoe



- b. Reaming the rat holes or cement plugs before drilling ahead
- c. Extra care tripping back through the casing shoe
- d. During jamming, dislodging or breaking up the obstructions by using alternating upward and downward movement and jarring and by gradually increasing freeing forces until the drill string is freed, as well as using acid to dissolve the extra cement.

### 12.2.8 Chapter 8: Cementing Problems

Cementing job is crucial to the overall integrity of the wellbore as cement is solely responsible for isolating the well from the surrounding. The efficiency of a cement job, however, depends on the rheological properties of the cement and on local geological conditions. This requires custom-made design for each well, taking into considerations unique features of the well. By focusing on failures that lead to cementing and eventual casing problems, this chapter makes it clear what should be good practice and bolsters the conclusions with an array of case studies of both the success and failure of cement jobs. Based on the presentation made in this chapter, the following conclusions can be made:

1. Every cement job must be custom-designed, based on the local geology and major features of the well. Conventional standard that offers one solution for all problems is grossly inadequate to solve cementing problems. The following factors play a role in the quality of a cement job:
  - a. the drilling fluid
  - b. use of spacers and flushes
  - c. movement and rotation of the pipe
  - d. centralizing the casing
  - e. the displacement rate
  - f. prevailing temperature and pressure conditions
  - g. cement composition
  - h. cement slurry volume and the volume of the spacer fluid.

Each of these factors needs to be considered. These factors are also to be reconsidered if a faulty cementing job is detected.

2. Remediation of a faulty cementing job is not the answer to cement problems. Best efforts should be made to ensure an

adequate primary cementing. In case sustained casing pressure (SCP) is identified, the cause(s) should be traced before attempting to remedy. Potential sources may be: corrosive fluid, erosive materials, fluids with incompatible pH, and mitigating pressure and temperature conditions. Often a combination of these may be responsible.

3. Maintaining stable temperature conditions is important in ensuring proper gelation of cement. Unnecessary loading of the well that provokes sudden temperature and pressure changes can affect cementing quality adversely.
4. Outside of production casings, it is important to consider both pore and fracture pressure to be able to design an adequate top of casing (TOC). It is important that TOC is so high that the requirements for setting of the production packer can be acquired with an acceptable margin.
5. If two fluid-bearing zones are supposed to be drilled through with the same mud, precaution has to be taken. It is important to make sure that the pore pressure in the lower zone is not too close to the fracture pressure in the upper zone.
6. Prior to any cement job, it is also important to remove mud cake as much as possible from the cement/formation interface in order to prevent poor bonding.
7. Cementing is hampered in the presence of oil-based mud (OBM). The formation of microcavities after curing time reduces the compressive strength of the set cement, and this could affect the stability of the hydraulic seal. This should be factored in the desired compressive strength of the cement or additives should be added to restore original compressive strength of the set cement.
8. Maintaining turbulent flow regime is crucial during cementing operations. Because calculations are based on uniform distribution of the velocity profile any deformation due to eccentricity can create different flow regimes in different segments. Use of centralizers to ensure casing is well centered with respect to wellbore and hence avoiding non-uniform and incomplete cement placement in the annular space is desirable. Also the use of cement packer completion using Liquid Cement Premix (LCP) in off-shore has been proven to be beneficial with workover rigs.
9. Keeping cement slurry weight at least 0.24 kg/l higher than mud and circulate cement at a very low flow rate to aid

displacement process is helpful in maintaining a piston-like displacement in the annulus.

10. In extended reach and horizontal wells, the heavier cement is even more important than in vertical wells. Isolating the cement by plugs while it is pumped down the casing is helpful. This is necessary to ensure that the cement fills the whole annulus properly and also to avoid cement contamination with muds.
11. Poor cement jobs can be averted or remedied by using one or more of the following techniques:
  - a. Use of centralizers when running in casings
  - b. Run casing with scratchers, hydraulic jetting or treatment with acids
  - c. Thinning the mud before running in casing
  - d. Isolating cement by plugs when pumping down
  - e. Establishing turbulent- or plug flow of cement slurry
12. For complex formations, scaled model studies must be made before cementing in order to determine the composition as well as pumping rate and setting time.
13. Early warning signs should be identified. The SCP values should be monitored closely and preventative measures taken before proceeding to next phase of drilling.
14. It is better to preempt regulations by developing company's own standards that conform to zero tolerance policy.

### 12.2.9 Wellbore Instability Problems

Borehole stability is synonymous with sustainable petroleum production. Any problem in the borehole is likely to snowball into a bigger crisis, often draining economic resources of the operating company. Borehole stability technology that includes both chemical and mechanical restoration is aimed at drilling a wellbore that would last the lifetime of the oil/gas field. Maintaining a stable borehole requires smooth operations involving cutting removal, cleaning, lubricating and cooling the bit, providing buoyancy to the drill-string, controlling formation fluid pressures, preventing formation damage, and providing borehole support and chemical stabilization. Borehole stability is challenged further due to the extra length of the horizontal wells. Based on the discussion in Chapter 9, the following conclusions can be reached:

1. Borehole instabilities are caused by mechanical or chemical causes. Mechanical causes include: failure caused by in-situ

stresses (including rock strength), erosion caused by fluid circulation, etc. Chemical effects, on the other hand, involve: rock/drilling fluid interaction, drilling fluid/native fluid interaction, etc.

2. Formation damage is the least harmful aspect of borehole instability. However, formation damage also signals greater dangers that might be ahead. *Air-based systems* can decrease formation damage and also addresses some of the environmental concerns, provided dust can be adequately controlled.
3. Uncontrollable factors that affect wellbore stability are:
  - a. Naturally fractured and/or faulted formations
  - b. Tectonically stressed formations
  - c. High in-situ stresses
  - d. Mobile formations
  - e. Unconsolidated formations
  - f. Naturally over-pressurized shale collapse
  - g. Induced over-pressurized shale collapse

In any drilling activity, these factors can trigger well instability and as such must be considered during the planning phase.

4. The controllable factors that affect wellbore stability are:
  - a. Bottomhole pressure
  - b. Well inclination and azimuth
  - c. Transient pore pressures
  - d. Physico-chemical rock-fluid interaction
  - e. Drillstring vibrations
  - f. Erosion
  - g. Temperature

Each of these factors affects uniquely and should be carefully evaluated in order to ensure optimum values of the overall drilling parameters.

5. Drilling fluid density can ensure wellbore stability at least for the drilling phase. The increase in drilling fluid density should not be too high, which would cause its loss or fracturing of the formation. Thus, drilling fluid density must be optimized.
6. Mechanical stability problem can be prevented by restoring the stress-strength balance through adjustment of mud

weight and effective circulation density (ECD) through drilling/tripping practices, and trajectory control. It comes down to balancing the hydraulic system against the inherent features of the formation.

7. Chemical instability is a hallmark of shale formations and can be prevented through selection of proper drilling fluid, suitable mud additives to minimize/delay the fluid/shale interaction, and by reducing shale exposure time. Selection of proper mud with suitable additives can even generate fluid flow from shale into the wellbore, reducing near wellbore pore pressure and preventing shale strength reduction.
8. Polymers are often recommended in order to reduce shale disintegration. To achieve effective results within the shale formation, polymer must be able to diffuse into the bulk shale, requiring short flexible chains.
9. Other preventative measures against chemically induced instability include the use of drilling fluids that have specific properties against chemical instabilities. Preventive measures include use of effective sealing agents for fractures, e.g., graded  $\text{CaCO}_3$ , high viscosity for low shear rates, and lower ECD.
10. Mechanical instability due to salt formation is best countered with high concentration brine solution in mud or the use of OBM. There are a number of other additives that can be used as well.
11. Field case studies reveal that drilling fluid density alone cannot restore wellbore integrity in a shaley or fractured formation. If the drilling density is too high, the pore pressure would increase and the effective stresses around the wellbore would decrease, leading to a larger damage. On the other hand, decreasing the drilling fluid filter loss and improving the drilling fluid rheological property would benefit wellbore stability.
12. The larger the inclination the greater the probability of wellbore instability. However, in the presence of the laminar fractures, decreasing the angle of the wellbore axial line with the bedding normal direction is of benefit for the wellbore stability.
13. For some situations, wellbore collapse cannot be prevented, so carrying out the cuttings in a timely way could decrease the downhole idle time.

14. In presence of high concentration formation water, high ionic concentration for the drilling fluid should be used to balance the formation water.
15. Vibrations lead to wellbore instability, as such all measures should be taken to minimize vibrations.
16. Case studies confirm the role of inclination in aggravating the wellbore instability. The trend continues into horizontal wells.

### 12.2.10 Chapter 10: Directional and Horizontal Drilling Problems

Horizontal wells gained great prominence over the last four decades. Each horizontal well also has a directional segment. It is well known that horizontal wells add to productivity that makes up for the additional cost of drilling a horizontal well. However, horizontal and directional wells also come with additional difficulties that often become overwhelming if not properly planned. Based on the discussion in Chapter 10, the following conclusions can be made:

1. Many factors can affect the trajectory of the drill bit and any anomalous behavior of these factors can lead to a bigger problem of the drilling process. These are all controllable factors.
  - a. formation effects (boundaries of various strata)
  - b. excessive weight on bit (WOB)
  - c. incorrect choice of BHA
  - d. improper calibration of the monitoring tool
  - e. the magnetic property of the drilling fluid.
2. Crookedness is one of the most important weaknesses of a horizontal/directional well. There are many causes behind a crooked borehole. Here are some of the important ones:
  - a. The most important reason for crookedness of a wellbore is the high weight on bit (WOB).
  - b. Formation Dip creates a pathway for the onset of crookedness of the wellbore.
  - c. Anisotropy: Most formations have vertical to horizontal permeability anisotropy with vertical permeability being much less (often an order of magnitude less) than horizontal permeability. Bedding.
  - d. Inadequate Length of Drill Collars.

- e. No stabilizer or ill positioned stabilizers can trigger unintentional sidetracking
3. In case the borehole is already crooked, the following remedial actions can be taken:
  - a. Plug Back and Sidetrack
  - b. Use Whipstock
  - c. Use Reamers
4. Washout is a common failure but can lead to complications. Twist-offs, on the other hand, are uncommon but far more consequential in terms of downtime and equipment loss.
5. Following are the features of horizontal and directional wells that make them vulnerable to drilling problems.
  - a. **Torque and Drag:** OBM should be considered for more demanding situation because its extra lubricating qualities.
  - b. **Hole Cleaning:** The horizontal section is vulnerable to drill cutting accumulation and plugging. High fluid velocities and polymer muds are useful for cleaning without causing formation damage. For shaley formations, oil-based muds can control shale swelling.
  - c. **Directional Control:** The BHA section, which controls the hole trajectory but does not contribute to WOB, should be kept as lightweight as possible to minimize torque and drag.
  - d. **Anisotropy:** Anisotropy affects horizontal wells different from vertical wells. Case studies show that drilling horizontal wells along the maximum horizontal stress is quite different from along the minimum horizontal stress direction and a reorientation is required.

### 12.2.11 Chapter 11: Environmental Hazard and Problems during Drilling

Concerns for the environment have been motivated by safety needs and liability considerations. With enhanced understanding of long-term consequences, the petroleum industry has been leading numerous initiatives for sustainable developments. These initiatives cover both short-term and long-term issues. As a result, the petroleum industry has improved its environmental and safety records. Based on the discussion presented in Chapter 11, the following conclusions can be made.

1. Acoustics during drilling cause environmental impacts that are often overlooked, mostly because new science is not equipped with the tools that can assess the long-term impacts of such intangibles. However, safety considerations are fully covered and acoustics do not pose any threat.
2. Air Quality is affected during drilling operations but doesn't go beyond relatively small areas.
3. Cultural Resources are routinely considered but the long-term impact of drilling on culturally sensitive sites remains a matter of debate.
4. The concept of environmental justice is a new one and has received considerable attention in recent years.
5. There are adequate protocols in handling hazardous materials during a drilling operation.
6. For handling drilling fluid waste and drill cuttings, there is still room for research as the long-term impacts are not well understood. In this analysis, the focus has been the crude oil and native materials, but scientifically the focus ought be chemicals that are added to the system. This aspect has received little attention and remains largely in the realm of academic research.
7. Drilling activities may affect surface and groundwater flows. The use of chemicals in drilling fluid, cement, and fracturing fluid has the risk of affecting the groundwater. This highlights the need of developing technologies that can seal the casing without using toxic chemicals.



## Index

- Abandonment (of well), 80, 96, 97, 294, 353  
Accelerator 35, 368  
African 35, 569  
Alarm 16, 22, 344–46, 576  
Aluminum 467, 582  
Anisotropy 65, 165, 513, 514, 527, 539, 611, 612  
API specification/standard 14, 387, 392, 441  
Axial vibration 143, 266, 267, 457  
  
Basalt 54  
Bingham (plastic) model, 56, 158, 383  
Bit, PDC 544, 545  
Bit, pilot 543, 545  
Blowout preventer 13, 127, 172, 203, 205, 207–9, 213–16, 220, 301, 354, 576, 596  
Blowout, underground 81, 176, 198, 199, 210, 211, 304  
BOP stack 13, 14, 315  
Borehole friction 258, 523  
Borehole geometry 228, 229, 230  
Buckling load 143, 495, 525, 526, 546  
Buckling force 289, 290  
Burst failure 143, 240  
Burst pressure 194, 195, 245  
Burst resistance 294, 331  
Bushing 158  
  
Cable tool 4, 35, 36  
Calcium carbonate 83, 85  
Calcium chloride 103  
Casing collapse 48, 294, 571  
Casing spool 25  
CBL log 405, 408, 411, 415, 419, 424, 428, 431, 436  
Cementing agent 85, 86  
Cementing job 215, 286, 354–356, 359, 370, 379, 394, 606  
Cementing parameter 129, 404, 407, 408, 410, 414, 418, 424, 430, 435, 436  
Cementing, primary 294–96, 319, 356–58, 361, 381, 607  
Cementing pump 196, 197  
Choke manifold 13–15  
Compaction 179, 561, 570, 571  
Compressibility 212  
Compressive strength 53, 56, 256, 356, 368, 369, 382, 388, 389, 397, 459, 480, 607  
Centralizer 288, 292, 368, 370, 371, 372–74, 386, 391, 395, 440, 604, 607, 608  
Clay stabilization 114, 115, 135  
Coiled tubing 4, 6, 75, 245, 464, 499, 508, 509  
  
Depletion 63, 81, 557, 562  
Derrick 4, 24, 25, 52, 128, 162, 513  
Dogleg 230, 236, 262, 362–64, 464, 509, 510, 518, 524  
Dogleg region 237, 525  
Dogleg severity 230, 254, 261, 262, 363, 544  
Downhole motor 499, 521  
Drill collar, nonmagnetic 504, 506–8, 521, 527, 547

- Drill cutting 156, 159, 160, 221, 385, 558, 563, 565, 581, 591, 593
- Drill cutting disposal 567
- Drill cutting management 563
- Drilling Components 579, 582
- Drilling Corrosivity 254
- Drilling Design 204
- Drilling mud company 5
- Drilling torque 48, 65
- Drillstring buckling 291, 349
- Drillstring vibration 143, 240, 264, 457, 494, 525, 546
  
- Endocrine 589
- Environmental sustainability 8
- Environmental degradation 551
- Environmental disaster 4, 550
  
- Fluid loss control 21, 383, 388, 389, 393
- Fire hazard 19
- Firefighting 201
- Fluoride 115
- Foamy fire retardant 203
  
- Geophysical data 596, 602
- Geophysical monitoring 213
- Geophysical surveys 551
- Green cement 101, 102, 229, 230
  
- Hoisting power 24, 25, 52, 162
- Hole deviation 4, 6, 12, 150, 167, 168, 363, 509, 511, 515, 516
- Hole enlargement 48, 143, 148, 149, 240, 465
  
- Inhibited audio 216
- Inhibited acid/liquid 229, 310
- Inhibitor 162, 456, 467
  
- Kelly 158, 178, 180, 261
  
- Laminar flow 120, 131, 160, 372
- Liner, contingency 128, 130
- Liner, hanger 315, 336, 338, 390, 434
- Liner, production 154, 208, 305, 331, 334
- Liner, slotted 315
- Lost circulation control agent 368
- LWD 64, 361, 364, 375, 376, 543
  
- Magnesium 99, 100, 104
- Magnesium chloride 103, 104
- Magnesium Chloride 103, 104
- Mud blowout 586
- Mud kick 529, 530
- Mud velocity 36, 120
- Multilateral well/drilling 6, 499, 527, 528, 545
- MWD log 23
- MWD tool 276, 403, 504, 527, 542
- MWD transmission 21
  
- Natural fractures 81, 295, 396, 425, 446, 465, 513, 572
- Newtonian 158, 372, 373
- Nominal weight 231, 247, 248
- Non-Newtonian 158, 383, 388
- Norwegian Continental Shelf (NCS) 464, 564, 578
- Norwegian offshore 400, 576
  
- Oil-based mud 11, 65, 97, 100–3, 126, 165, 239, 367, 368, 467, 527, 543, 544, 599, 607, 612
- Overburden 86, 311, 313–15, 451, 528, 575
- Overburden pressure 150, 151, 164, 299, 573
- Overburden stress 513
  
- Perforation 36, 286, 294, 296, 314, 320, 321
- Pit volume 176, 177, 178, 180, 185, 204, 344, 601
- Poisson's ratio 464
- Porosity 51, 52, 71, 72, 110, 173, 176, 179, 369, 513
- Precipitation 101, 104, 106, 110, 112, 115

- Relief valve 22
- Relief well 197, 199, 203, 209, 213, 347
- Roller reamer 482, 515
  
- Safety factor 233, 242–48
- Salt diapirs 67
- Salt dome 86, 103, 169, 203, 448, 595
- Salt formation 81, 82, 274–76, 287, 448, 539–42, 544, 575, 599, 610
- Sealing pressure 95
- Seismic characteristics 19
- Seismic data 17, 18, 402, 403, 470, 540, 575
- Seismic excitation 124
- Shale cutting 466, 484, 486, 488
- Shale shaker 13, 15, 65, 72, 100, 488, 494
- Spill, oil 206, 209, 217, 220, 440, 550, 563, 586
- Squeeze, cement 89, 129, 167, 294, 320, 340, 395, 402, 403, 605
- Squeeze, gunk 127
- Sustainability 2, 7, 584, 595
  
- Tectonically active 69, 513
- Tectonics 314
- Tectonic movement 470
- Tectonic plate 447
- Tectonic stress 165, 446–48, 609
- Thermal expansion 178, 293, 400, 464
- Thickening time 368, 382, 387, 388, 389, 393
- Thixotropic 383
- Torque deflection 47
- Transition zone 88, 166, 255, 275, 367, 524, 599
  
- Triaxial 289, 460, 502
- True sustainability 7, 592
- True vertical depth (TVD) 196, 241, 301, 403, 404, 407, 411, 415, 418, 423, 430, 435, 484, 499, 503, 541
- Turbulent flow 21, 51, 120, 158, 384, 387–89, 607
  
- Underreamer 278, 481
- Ultrasonic 124, 369, 566, 572, 599
  
- Vibration, axial 143, 266, 267, 457
- Vibration control 254, 274
- Vibration induced anomalies 264
- Vibration, lateral 276, 277, 457, 515
- Vibration, torsional 238, 267, 268, 278, 457, 515
- Vibration, drillstring 143, 240, 264, 457, 494, 525, 546
- Visco-elastic 204
- Viscometer 385
- Viscosifier 467
  
- Water injection 25, 27, 113, 197, 319, 323, 324
- Water table 298
- Wetting agent 369
- Wireline fishing 258, 508
- Wireline log 123, 442, 543
  
- Yield pressure 195, 243, 244, 399
- Yield strength 163, 233, 236, 246, 247, 250, 289, 292, 293, 383
- Young's modulus 227, 239, 464