

# Pipeline Design for Installation by Horizontal Directional Drilling



**ASCE**

# Pipeline Design for Installation by Horizontal Directional Drilling

Prepared by the HDD Design Guideline Task Committee  
of the Technical Committee on Trenchless Installation  
of Pipelines (TIPS) of the Pipeline Division  
of the American Society of Civil Engineers



Published by the American Society of Civil Engineers

Library of Congress Cataloging-in-Publication Data

Pipeline design for installation by horizontal directional drilling : ASCE manual of practice.

p. cm.

Includes bibliographical references and index.

ISBN 0-7844-0804-1

1. Directional drilling. I. American Society of Civil Engineers.

TN871.2.P52 2005

622'.3381—dc22

2005012324

Published by the American Society of Civil Engineers

1801 Alexander Bell Drive

Reston, Virginia 20191

[www.pubs.asce.org](http://www.pubs.asce.org)

Any statements expressed in these materials are those of the individual authors and do not necessarily represent the views of ASCE, which takes no responsibility for any statement made herein. No reference made in this publication to any specific method, product, process, or service constitutes or implies an endorsement, recommendation, or warranty thereof by ASCE. The materials are for general information only and do not represent a standard of ASCE, nor are they intended as a reference in purchase specifications, contracts, regulations, statutes, or any other legal document.

ASCE makes no representation or warranty of any kind, whether express or implied, concerning the accuracy, completeness, suitability, or utility of any information, apparatus, product, or process discussed in this publication, and assumes no liability therefore. This information should not be used without first securing competent advice with respect to its suitability for any general or specific application. Anyone utilizing this information assumes all liability arising from such use, including but not limited to infringement of any patent or patents.

ASCE and American Society of Civil Engineers—Registered in U.S. Patent and Trademark Office.

*Photocopies:* Authorization to photocopy material for internal or personal use under circumstances not falling within the fair use provisions of the Copyright Act is granted by ASCE to libraries and other users registered with the Copyright Clearance Center (CCC) Transactional Reporting Service, provided that the base fee of \$25.00 per article is paid directly to CCC, 222 Rosewood Drive, Danvers, MA 01923. The identification for this book is 0-7844-0804-1/05/\$25.00. Requests for special permission or bulk copying should be addressed to Permissions & Copyright Dept., ASCE.

Copyright © 2005 by the American Society of Civil Engineers.

All Rights Reserved.

Library of Congress Catalog Card No. 2005012324

ISBN 0-7844-0804-1

# MANUALS AND REPORTS ON ENGINEERING PRACTICE

(As developed by the ASCE Technical Procedures Committee, July 1930, and revised March 1935, February 1962, and April 1982)

A manual or report in this series consists of an orderly presentation of facts on a particular subject, supplemented by an analysis of limitations and applications of these facts. It contains information useful to the average engineer in his everyday work, rather than the findings that may be useful only occasionally or rarely. It is not in any sense a "standard," however; nor is it so elementary or so conclusive as to provide a "rule of thumb" for nonengineers.

Furthermore, material in this series, in distinction from a paper (which expressed only one person's observations or opinions), is the work of a committee or group selected to assemble and express information on a specific topic. As often as practicable the committee is under the direction of one or more of the Technical Divisions and Councils, and the product evolved has been subjected to review by the Executive Committee of the Division or Council. As a step in the process of this review, proposed manuscripts are often brought before the members of the Technical Divisions and Councils for comment, which may serve as the basis for improvement. When published, each work shows the names of the committees by which it was compiled and indicates clearly the several processes through which it has passed in review, in order that its merit may be definitely understood.

In February 1962 (and revised in April 1982) the Board of Direction voted to establish:

A series entitled "Manuals and Reports on Engineering Practice," to include the Manuals published and authorized to date, future Manuals of Professional Practice, and Reports on Engineering Practice. All such Manual or Report material of the Society would have been refereed in a manner approved by the Board Committee on Publications and would be bound, with applicable discussion, in books similar to past Manuals. Numbering would be consecutive and would be a continuation of present Manual numbers. In some cases of reports of joint committees, bypassing of Journal publications may be authorized.

# MANUALS AND REPORTS ON ENGINEERING PRACTICE

No.	Title
13	Filtering Materials for Sewage Treatment Plants
14	Accommodation of Utility Plant Within the Rights-of-Way of Urban Streets and Highways
35	A List of Translations of Foreign Literature on Hydraulics
40	Ground Water Management
41	Plastic Design in Steel: A Guide and Commentary
45	Consulting Engineering: A Guide for the Engagement of Engineering Services
46	Pipeline Route Selection for Rural and Cross-Country Pipelines
47	Selected Abstracts on Structural Applications of Plastics
49	Urban Planning Guide
50	Planning and Design Guidelines for Small Craft Harbors
51	Survey of Current Structural Research
52	Guide for the Design of Steel Transmission Towers
53	Criteria for Maintenance of Multilane Highways
55	Guide to Employment Conditions for Civil Engineers
57	Management, Operation and Maintenance of Irrigation and Drainage Systems
59	Computer Pricing Practices
60	Gravity Sanitary Sewer Design and Construction
62	Existing Sewer Evaluation and Rehabilitation
63	Structural Plastics Design Manual
64	Manual on Engineering Surveying
65	Construction Cost Control
66	Structural Plastics Selection Manual
67	Wind Tunnel Studies of Buildings and Structures
68	Aeration: A Wastewater Treatment Process
69	Sulfide in Wastewater Collection and Treatment Systems
70	Evapotranspiration and Irrigation Water Requirements
71	Agricultural Salinity Assessment and Management
72	Design of Steel Transmission Pole Structures
73	Quality in the Constructed Project: A Guide for Owners, Designers, and Constructors
74	Guidelines for Electrical Transmission Line Structural Loading
76	Design of Municipal Wastewater Treatment Plants

No.	Title
77	Design and Construction of Urban Stormwater Management Systems
78	Structural Fire Protection
79	Steel Penstocks
80	Ship Channel Design
81	Guidelines for Cloud Seeding to Augment Precipitation
82	Odor Control in Wastewater Treatment Plants
83	Environmental Site Investigation
84	Mechanical Connections in Wood Structures
85	Quality of Ground Water
86	Operation and Maintenance of Ground Water Facilities
87	Urban Runoff Quality Manual
88	Management of Water Treatment Plant Residuals
89	Pipeline Crossings
90	Guide to Structural Optimization
91	Design of Guyed Electrical Transmission Structures
92	Manhole Inspection and Rehabilitation
93	Crane Safety on Construction Sites
94	Inland Navigation: Locks, Dams, and Channels
95	Urban Subsurface Drainage
96	Guide to Improved Earthquake Performance of Electric Power Systems
97	Hydraulic Modeling: Concepts and Practice
98	Conveyance of Residuals from Water and Wastewater Treatment
99	Environmental Site Characterization and Remediation Design Guidance
100	Groundwater Contamination by Organic Pollutants: Analysis and Remediation
101	Underwater Investigations
102	Design Guide for FRP Composite Connections (ON HOLD)
103	Guide to Hiring and Retaining Great Civil Engineers
104	Recommended Practice for Fiber-Reinforced Polymer Products for Overhead Utility Line Structures
105	Animal Waste Containment in Lagoons
106	Horizontal Auger Boring Projects
107	Ship Channel Design and Operation
108	Pipeline Design for Installation by Horizontal Directional Drilling

# CONTENTS

<b>CONTRIBUTORS</b> .....	<b>vii</b>
<b>1 INTRODUCTION</b> .....	<b>1</b>
1.1 Scope .....	1
<b>2 PREDESIGN SURVEYS</b> .....	<b>3</b>
2.1 Introduction .....	3
2.2 Surface Survey .....	3
2.3 Subsurface Investigation .....	4
<b>3 DRILLED PATH DESIGN</b> .....	<b>13</b>
3.1 Introduction .....	13
3.2 Penetration Angles .....	15
3.3 Depth of Penetration .....	15
3.4 Radius of Curvature .....	16
3.5 Directional Accuracy and Tolerances .....	16
3.6 Multiple-Line Installations .....	17
3.7 Casings .....	17
<b>4 PIPE DESIGN</b> .....	<b>19</b>
4.1 Introduction .....	19
4.2 Installation Loads .....	19
4.3 Operating Loads .....	23
4.4 Pipe Material .....	24
4.5 Stresses in Steel Pipe .....	26
4.6 Stresses in High-Density Polyethylene Pipe .....	31
4.7 Steel Pipe Corrosion Coating .....	35
<b>5 CONSTRUCTION IMPACT</b> .....	<b>37</b>
5.1 Introduction .....	37

5.2	Workspace.....	37
5.3	Drilling Fluid.....	38
<b>6</b>	<b>AS-BUILT DOCUMENTATION.....</b>	<b>45</b>
6.1	Introduction.....	45
6.2	Construction Staking.....	45
6.3	Documentation of Actual Drilled Path Endpoints.....	45
6.4	Measurements Required Prior to Commencing Drilling Operations.....	47
6.5	Pilot Hole As-Built Calculations.....	47
6.6	Surface Monitoring System.....	48
6.7	Pilot Hole As-Built Error Distribution.....	49
6.8	Pilot Hole As-Built Drawing.....	49
6.9	Postinstallation Survey.....	51
	<b>GLOSSARY.....</b>	<b>53</b>
	<b>REFERENCES.....</b>	<b>61</b>
	<b>SI CONVERSION TABLE.....</b>	<b>63</b>
	<b>INDEX.....</b>	<b>65</b>

## CONTRIBUTORS

*Prepared by the HDD Design Guideline Task Committee under the supervision of the Pipeline Division's Technical Committee on Trenchless Installation of Pipelines*

**John D. Hair, P.E., Chairman**

J. D. Hair & Associates, Inc.  
2121 South Columbia Ave., Suite 101  
Tulsa, OK 74114

**Dr. Mohammad Najafi, P.E., Vice-Chairman**

Michigan State University  
205 Farrall Hall  
East Lansing, MI 48824-1323

**Hugh O'Donnell, P.E.**

O'Donnell Associates, Inc.  
P. O. Box 429  
Fresno, TX 77545-0429

**Timothy M. Stinson, P.E.**

S E A Consultants, Inc.  
485 Massachusetts Avenue  
Cambridge, MA 02139-4018

**Eric R. Skonberg, P.E.**

Trenchless Engineering Corporation  
15015 Inverrary Drive  
Houston, TX 77095

**Tim McGuire**

Michels Pipeline Construction, Inc.  
P. O. Box 128  
Brownsville, WI 53006



**L. D. Garrett, P.E.**

Consultant  
12 Troon Drive  
Austin, TX 78738

**George J. Vogler**

Reserved Resource Insurance  
2200 North Overholser Drive  
Oklahoma City, OK 73127-9605

**Larry J. Petroff**

Chevron Phillips Chemical Company LP  
5085 W Park Blvd., Suite 500  
Plano, TX 75093

*In addition to the Task Force, other reviewers included*

**Vince Rybel**

CH2M Hill  
2300 NW Walnut Blvd.  
Corvallis, OR 97330

**Steven R. Kramer**

Jacobs Civil Inc.  
1100 North Glebe Road, Suite 500  
Arlington, VA 22201

**William R. Ledbetter**

El Paso Energy  
13019 Lynn Haven  
Cypress, TX 77429

**Chih-Hung Lee**

Pacific Gas & Electric Company  
375 North Wiget Lane, Suite 200  
Walnut Creek, CA 94598

**Ahmad Habibian**

Black & Veatch Corp.  
18310 Montgomery Village Ave., Suite 500  
Gaithersburg, MD 20879

# Section 1

## INTRODUCTION

### 1.1 SCOPE

This Manual of Practice addresses the design of major pipeline or duct segments to be installed by horizontal directional drilling (HDD). Generally speaking, major pipeline segments are greater than 500 ft in length and greater than 4 in. in diameter. They are installed by medium to large HDD rigs (Midi- to Maxi-HDD rigs). The design practices described in this Manual are not generally applicable to small trenchless segments of pipe, duct, or cable installed by "Mini-HDD" rigs.

Horizontal directional drilling is a trenchless excavation method accomplished in three phases. The first phase consists of drilling a small-diameter pilot hole along a designed directional path. The second phase consists of enlarging the pilot hole to a diameter suitable for installation of the pipe. The third phase consists of pulling the pipe into the enlarged hole. Horizontal directional drilling is accomplished using a specialized horizontal drilling rig with ancillary tools and equipment.

This Manual has been prepared to serve as a guide for design engineers and presumes that the user has knowledge of the HDD installation process and pipeline design methods. Topics covered are limited to those related to HDD installation. Other sources of information and design methods should be consulted for guidance on designing the pipeline to satisfy service requirements. This Manual is not a general design handbook for pipelines, and it is not meant to replace sound engineering judgment. Users of this manual should recognize that HDD installations are complicated civil engineering works and only experienced professional engineers should undertake their design.

*This page intentionally left blank*

## **Section 2**

# **PREDESIGN SURVEYS**

### **2.1 INTRODUCTION**

A successful HDD project requires that surface features and subsurface geotechnical and utility data be gathered and incorporated into its design. Trenchless installation methods require the design engineer to provide the contractor with sufficient information to reasonably anticipate the obstacles that may be encountered and how drilling operations should be carried out. During the design phase, surface and subsurface survey information will assist in determining the suitability of utility installation by the HDD process.

This section describes data that need to be gathered and presented to enhance the prospects for a successful HDD installation. Obtaining and providing accurate surface and subsurface information will result in fewer installation problems and change orders during the work.

### **2.2 SURFACE SURVEY**

Once it has been determined that HDD will be utilized, a surface survey is typically performed. Prior to conducting the actual survey, the design engineer should investigate the site to determine the limits of work required for equipment staging and setup, pipe layout, and areas of potential impact such as adjacent utilities or structures. The survey should be performed in an area sufficient in size to show equipment setup and storage locations. Typical staging areas required for HDD construction projects are discussed in Section 5.

The survey should be conducted along the proposed drill path centerline for a width of approximately 100 ft. Each HDD project has specific staging requirements that should be identified by the design engineer prior to initiating the field survey.

Information to be gathered during the survey should include, but not be limited to, the following:

- Existing grade elevation data referenced to a public datum if practical;
- Surface features such as roadways, sidewalks, utility poles, overhead power lines, and fire hydrants;
- Ledge or rock outcrops;
- Boring/test pit locations;
- Waterways;
- Potentially delineated wetlands;
- Culverts;
- Visible subsurface utility landmarks such as manholes or valve boxes; and
- Structures such as buildings, towers, or bridges adjacent to the proposed drilled path.

A plan view of a finished survey for a major HDD river crossing is shown in Figure 2-1. Contours are useful, but not imperative, as HDD activities on the surface are limited to entry and exit point work areas. It is important to note that HDD crossings designed with significant elevation differences between entry and exit will present unique challenges to HDD construction and should be readily apparent on the design drawing. Controlled aerial photographs, if recently taken, are commonly used and can eliminate the need for surveying many surface features.

Waterway crossings may also require a hydrographic survey. The hydrographic survey should include tidal ranges and edges of waterways. It should be conducted along the proposed drill path and include data as appropriate upstream and downstream of the path. As with the surface survey, bottom contours are useful but not imperative unless dramatic variations in bathymetric elevations are anticipated. Most drilled paths are designed well below a waterway bottom and small variations in elevation do not impact design.

## 2.3 SUBSURFACE INVESTIGATION

Once the surface survey data have been obtained, evaluation of subsurface features can be initiated. Subsurface feature concerns that may impact HDD design and therefore should be investigated include presence of existing utilities, adjacent structure foundations or other man-made obstructions, and geotechnical conditions along the proposed HDD alignment.

### 2.3.1 Utility Research

Utility survey information is important to the planning and execution of the HDD project. Unlike conventional open-cut installations, HDD projects require the contractor to install the utility line in the "blind." Unable to see

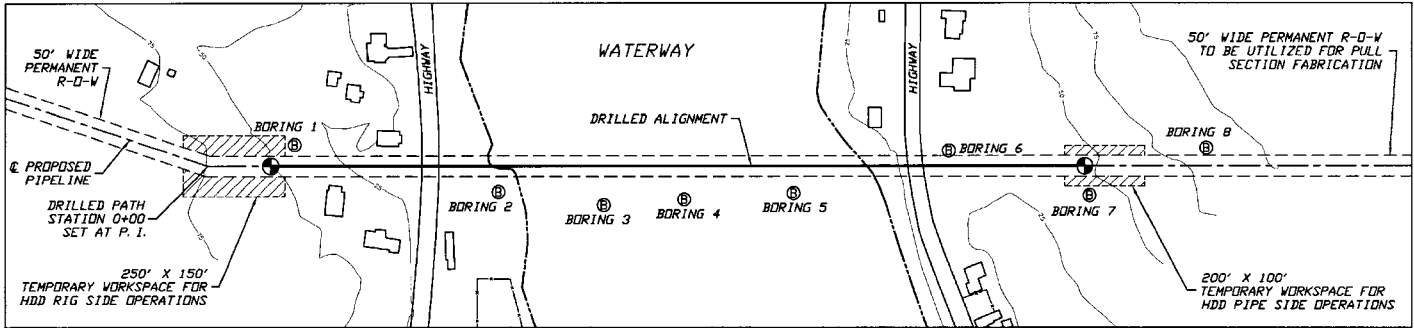

FIGURE 2-1. A Survey of a Major HDD River Crossing.

what obstructions he is faced with, the contractor should be given a record of potential conflicts and utility clearances as completely and accurately as may be obtained by reasonable and diligent inquiry. Guidance with respect to subsurface utility research may be found in *ASCE Standard 38-02*.

The first step in obtaining subsurface utility information is accomplished during the surface survey by locating visible subsurface utility landmarks. Knowing where valve boxes, manholes, and other structures are located will provide a starting point for utility research. The design engineer should exercise due diligence in not only identifying what utilities are located along the proposed HDD path, but also in determining their horizontal and vertical positions, especially if the existing utility was installed via HDD construction.

One method of obtaining utility data is to contact the local “one-call” locating service. This is a relatively easy and straightforward way for identifying and locating utilities that are members of the one-call network. In areas where one-call assistance is not provided during the design phase of work, municipalities and private utility companies should be contacted to obtain the required information. Additional research is often necessary, however, since not all utilities belong to the one-call network and one-call locates are not always clear with respect to depth. This is particularly true in the case of utilities installed by HDD. Postconstruction locating methods are often not effective because of the significant depth of HDD installations.

Obtaining as-built record drawings will give the design engineer location information and identify many, if not all, of the utility lines that may be encountered. However, because of the possibility of inaccurate information, reliance solely upon record drawings may not be sufficient for construction. Because of the potential impact and damage to utility lines due to HDD operations, it is vital that the contractor conduct additional investigations before beginning work to verify where utility lines are at risk of damage from new construction activities.

Generally, if the HDD alignment is expected to pass within 10 ft of an existing utility it is prudent to physically confirm the location prior to initiating HDD operations if possible. Utilities located greater than 10 ft away may also require physical locating, depending on specific requirements of the utility owner or the presence of unusual ground conditions along the proposed HDD alignment.

Methods of confirming subsurface utility locations include

- Pipe locators;
- Ground penetrating radar;
- Probing;
- Manual excavation;
- Vacuum excavation; and
- Seismic survey.

**2.3.1.1 Pipe Locators.** Utility lines can have both horizontal and vertical locations identified by means of surface-applied pipe locators. Pipe locators can be instruments that simply locate underground lines by means of a magnetic field application similar to that of a metal locator. More sophisticated locators require imposing an electric current on the utility line. Applied current travels along the utility and is detected and traced with the pipe locator. Nonmetallic pipe, such as PVC or high-density polyethylene (HDPE), that has not been installed with a tracing wire cannot be detected with a pipe locator. Some underground utility lines such as electric and cable television lines can produce a detectable signal as long as current is flowing through them. Pipe locators are generally less accurate with depth, but can be extremely accurate in locating utilities buried less than 8 ft deep, depending on conditions.

**2.3.1.2 Ground-Penetrating Radar.** Ground-penetrating radar (GPR) utilizes radio waves to detect underground lines and surfaces. When an object is detected, the radio waves reflect back to the receiver that records the information. The data are downloaded onto a computer, and a profile of the utility and geologic information is plotted for interpretation. Subsurface obstructions such as rock and groundwater surfaces are also detected by GPR and can result in misinterpretation of the gathered data. Since interpretation of the data is a critical element in GPR surveys, this method should be used in conjunction with other subsurface survey methods to improve the accuracy of the information. Ground-penetrating radar is most useful in depths less than 20 ft where the density of the object or utility in question contrasts greatly with the surrounding ground. In addition GPR is highly dependent on soil type and moisture content, is more effective in dry sands than wet soils, and does not work well in clay soils or in identifying pipe made of clay.

**2.3.1.3 Vacuum Excavation.** Nondestructive vacuum excavation is used to physically remove soil and expose the utility lines being investigated. Unlike test pitting, which is performed by means of excavation equipment such as a backhoe, vacuum excavation removes the soils by means of high-pressure air or water jetting. This method reduces the risk of damage to existing utility lines. The soil is loosened by means of the air or water and is vacuumed to a truck for replacement upon completion of the survey. Vacuum excavation allows for physical identification of horizontal and vertical position and pipe material, and also provides the designer with information concerning soil types and water table levels. Conventional vacuum excavation is limited to depths of approximately 20 ft and is most effective in unsaturated, medium-density, gravel size or less granular soils. Excavation holes must be large enough to allow for visual inspection of the utility lines.



**2.3.1.4 Seismic Surveys.** Seismic surveys require that a small explosive charge or impact by means of sledgehammer be initiated and detected via a series of detectors or geophones spaced along the path of the utility line. A time recorder is used to denote the time of origin of the wave and time of arrival at each detector. Similar to GPR, the water table and type of subsurface material impact the data output; therefore, proper interpretation of the data is critical, and greater density contrasts tend to yield more beneficial results. Seismic surveys are generally used in noncongested areas or locations where deep utility installations have taken place. Once the subsurface utility information is obtained, it should be correlated to determine possible conflicts and then included on the survey base drawings.

### **2.3.2 Geotechnical Investigation**

A second phase of subsurface investigation for HDD projects is the determination of soil conditions. Once the proposed routing has been identified, a geotechnical investigation should be performed. The geotechnical investigation should be tailored to suit the complexity of installation being designed. Investigations for complex installations should consist of two phases, a general geologic review and a geotechnical survey. A geotechnical survey alone may be sufficient for simpler installations.

A general geologic review involves examining existing geological data to determine what conditions might be encountered in the vicinity of the installation. Existing data may be available from construction project records in the area of the HDD (buildings, piers, bridges, levees, etc.). Such an overall review will provide information that may not be developed from a geotechnical survey consisting only of exploratory borings. It also allows the geotechnical survey to be tailored to the anticipated conditions at the site, thus enhancing the effectiveness of the survey.

A typical geotechnical survey consists of taking exploratory borings to collect soil samples for classification and laboratory analysis. Methods utilized in the survey of underground utilities, as described previously, can also be incorporated into the geotechnical survey.

The number, location, and depth of exploratory borings should be determined taking into account site-specific conditions such as the general geology of the area, availability of access, availability of existing data, cost, etc. Borings should be located off of the drilled path centerline to reduce the possibility of drilling fluid inadvertently surfacing through the borings during HDD operations. The borings should penetrate to an elevation below the depth of the proposed drilled path to provide information for design modifications as well as anticipated pilot hole deviations during construction. Areas of geologic transition and/or significant contrast in physical ground properties can present unique challenges to HDD construction and should be carefully scrutinized with greater frequency of investigation.

Sampling interval and technique should be set to accurately describe subsurface material characteristics, taking into account site-specific conditions. Typically, split spoon samples will be taken in soft soil at 5-ft-depth intervals in accordance with *ASTM D 1586-99*. Where rock is encountered, it should be cored in accordance with *ASTM D 2113-99*, to the maximum depth of the boring. The following data should be developed from exploratory soil borings:

- Standard classification of soils in accordance with *ASTM D 2487-00*;
- Gradation curves for granular soils containing gravel;
- Standard penetration test (SPT) values where applicable (generally unconsolidated ground);
- Cored samples of rock with lithologic description, rock quality designation, and percent recovery;
- Unconfined compressive strength for representative rock samples (frequency of testing should be proportionate to degree of variation encountered in rock core samples); and
- Mohs hardness for rock samples.

Steps for abandoning the exploratory borings based on local requirements must be undertaken. At a minimum, borings must be backfilled in a manner that will minimize the possibility of drilling fluid migration along the borehole during subsequent HDD operations. A mixture containing cement grout and a bentonite product to promote expansion is recommended. Cuttings from the drilling operation may be incorporated into the backfill mixture if considered beneficial. The upper 5 ft of land-based borings should be backfilled with the surrounding soil.

The results of the subsurface survey should be presented in the form of a geotechnical report containing engineering analysis, boring logs, test results, and a profile of the subsurface conditions. It is also useful, but not imperative, to present exploratory boring logs on the drilled path profile. An example of this is shown in Figure 2-2.

It should be noted that the presentation of geotechnical information by the design engineer can have significant contractual implications. This topic is examined in the ASCE publication, *Geotechnical Baseline Reports of Underground Construction: Guidelines and Practices* (1997). The concepts of a geotechnical baseline report (GBR) and a geotechnical data report (GDR) are discussed in this publication. If it is desired to establish a contractual statement of subsurface geotechnical conditions that may be encountered during the directional drilling, a GBR or GDR may be included in the contract documents.

A GBR can include detailed descriptions of the field and laboratory methods and procedures utilized in the subsurface exploration program. Typical information includes boring logs, laboratory test results, and profile data.

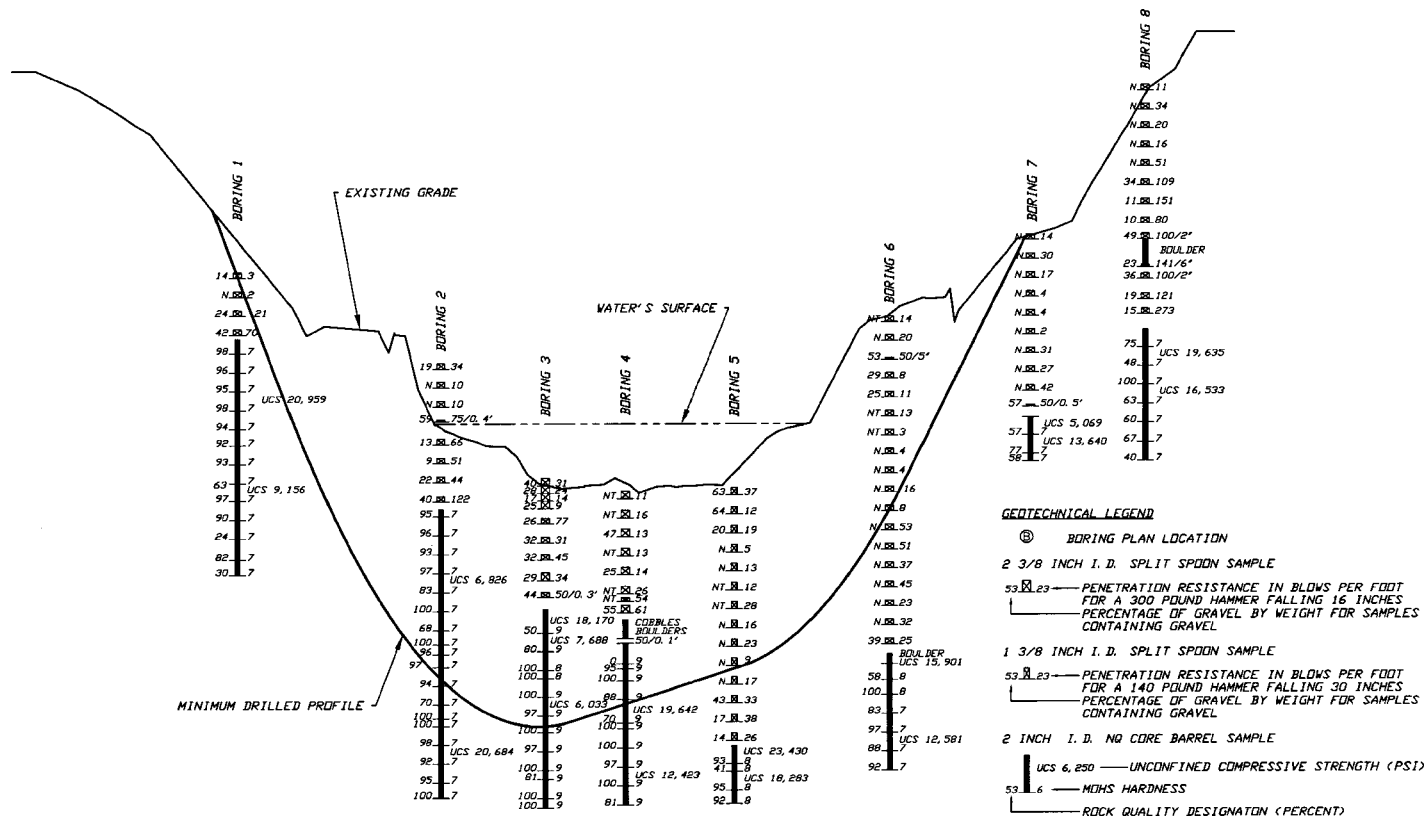

FIGURE 2-2. A Geotechnical Report Showing Results of a Subsurface Survey.

For more complex projects, consideration may be given to preparing a GDR for inclusion in the documents. The GDR is typically limited to interpretive discussion and baseline statements and makes reference to the information contained in the GBR.

However, in establishing a contractual statement of subsurface geotechnical conditions for an HDD project, it should be remembered that the conditions along a drilled path will rarely be visible. It will generally not be possible to verify actual subsurface conditions encountered versus the established baseline conditions. Experienced engineering judgment should be applied in evaluating and allocating risk taking into account site-specific conditions.

### **2.3.3 Hazardous Material Investigation**

Since the drill operations will result in spoil materials being produced that will require handling and disposal, soil and/or groundwater samples should be taken during the utility and geotechnical investigations. During the geotechnical and utility excavation programs, soils and groundwater should be examined by both visual and olfactory means to determine whether potential hazardous materials exist, and samples should be analyzed to determine whether hazardous waste problems are indicated. Testing will vary, depending upon the site and actual conditions encountered; however, typical analysis can include

- Volatile organic compounds (VOC);
- Base/neutral extractable organic compounds;
- Total petroleum hydrocarbons (TPH);
- RCRA 8 metal analyses; and
- Pesticides/PCBs.

Samples should be taken and analyzed in accordance with applicable state and Environmental Protection Agency (EPA) regulations and methods.

*This page intentionally left blank*

## Section 3

# DRILLED PATH DESIGN

### 3.1 INTRODUCTION

A properly designed HDD installation includes a specific drilled path design. The first step in designing a drilled path consists of defining the obstacle to be crossed. At first glance this seems to be a simple task. However, obstacles in today's construction environment can be complicated and subtle.

Consider a river crossing, which is an obvious obstacle. However, a river is a dynamic entity. Channels can migrate vertically and horizontally. A successfully designed drilled path will take into account not only the present location of the channel, but also its potential future locations (Hair and Hair 1988, p. 15; O'Donnell 1978, pp. 511–517). Additional obstacles can be associated with a river. A riparian barrier of trees may need to be preserved and thus included in the drilled path. An environmentally sensitive wetland may be associated with the river and included in the drilled path. Conversely, the actual bank-to-bank distance of a river may exceed the distance that would make a drilled crossing technically or economically feasible. In this case the drilled segment may be designed to cross the deep channel of the waterway using marine equipment to support the rig and construct approaches through shallower water where cut and cover construction is more economical.

Once the obstacle has been defined and the approximate desired HDD length is established, designing and specifying a drilled path is a fairly straightforward exercise in geometry (Hair and Hair 1988, p. 17). The location and configuration of a drilled path are defined by

- Penetration angles;
- Design radius of curvature;
- Points of curvature and tangency; and
- Desired vertical depth of cover.

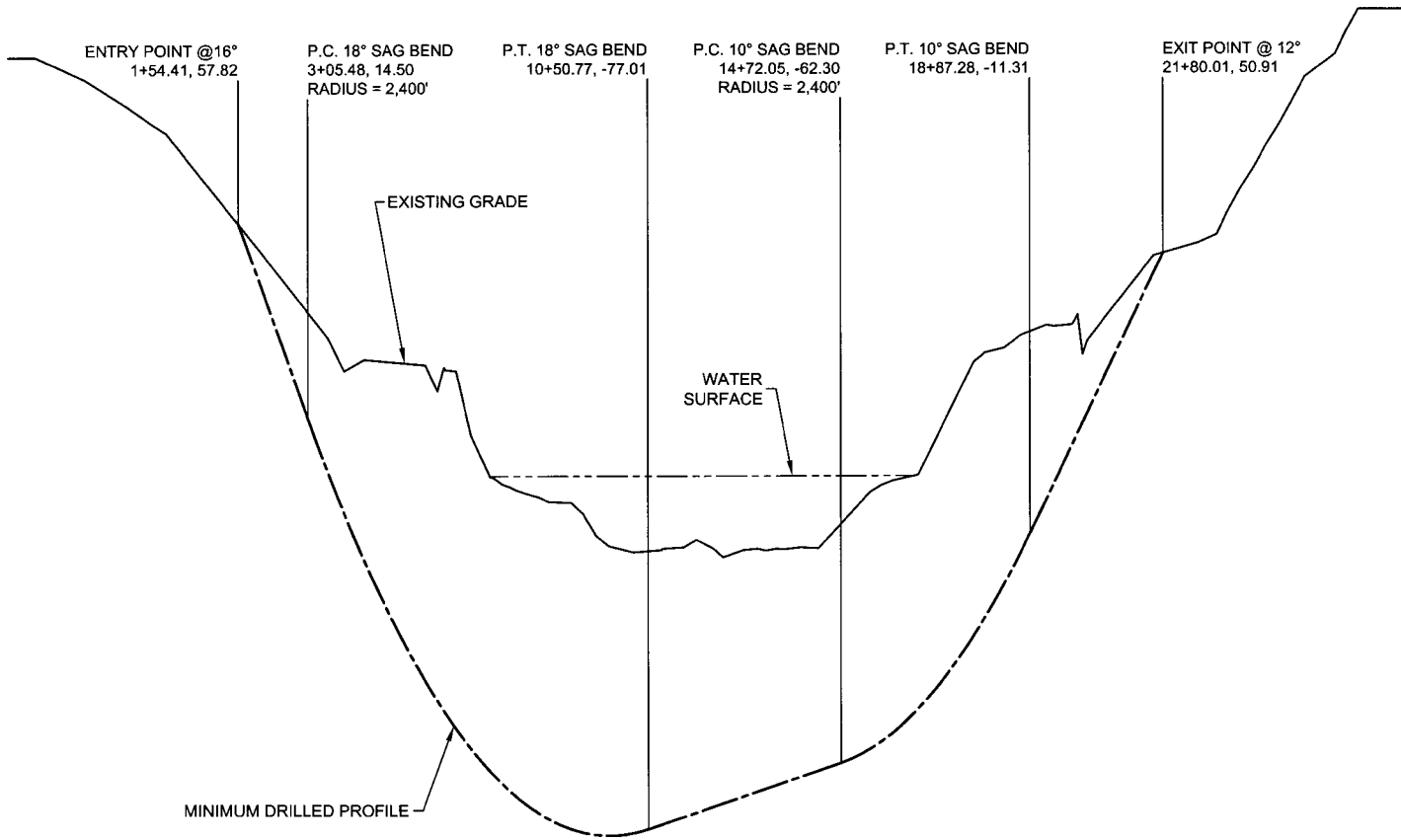

FIGURE 3-1. A Typical Designed Drill Path.

A primary consideration in designing the drilled path is minimization of drilled length. Minimizing the drilled length of an HDD crossing will reduce installation costs. However, the design must also consider availability of workspace at the entry and exit locations such that the HDD can be feasibly constructed within the physical site constraints. Lastly, the design is often influenced by the geologic conditions identified and is placed at depths most amenable to the HDD process.

A typical designed drilled path is shown in Figure 3-1. It follows a straight alignment in the horizontal plane. The designer should be aware that HDD offers the flexibility of changing alignment through horizontal curves in a manner similar to the change of vertical position through the use of vertical curves. However, horizontal curves can be difficult to drill accurately and, depending on the deflection angle, can significantly increase pulling forces. Therefore, horizontal curves should only be used after due consideration and analysis have been given to their potential negative impact on constructability.

### 3.2 PENETRATION ANGLES

Penetration angles are measured from the horizontal. Entry angles are limited by equipment capabilities and should generally be designed between  $8^{\circ}$  and  $20^{\circ}$  (DCCA 1995, para. D.2; Hair and Hair 1988, p. 18). Most horizontal drilling rigs are designed to function best between  $10^{\circ}$  and  $12^{\circ}$ . However, for large-diameter pipelines, entry angles may be less than  $8^{\circ}$ .

Exit angles should be designed to provide ease in breakover support of the pull section. High exit angles will require the pull section breakover bend to be supported at an elevated position during pullback. Exit angles should generally range from  $5^{\circ}$  (for large-diameter steel pipelines) to  $12^{\circ}$ . As part of a general constructability review, the design engineer should check pull section handling requirements to evaluate the constructability of the design.

### 3.3 DEPTH OF PENETRATION

The depth of penetration is primarily controlled by the definition of the obstacle. However, the design engineer should also consider other factors, such as geotechnical features, when selecting a penetration elevation. A minimum of 15 ft of separation beneath the obstacle should be maintained (DCCA 1995, para. D.1; Hair and Hair 1988, p. 18). Twenty-five ft is recommended as a standard separation distance, especially for less



favorable drilling conditions. This minimum distance provides a margin for error in surveying methods both before and during construction. It should be noted that permit requirements may exceed the values previously stated. In determining the depth of penetration, the design engineer should take into account the risks of inadvertent drilling fluid returns and surface settlement or heaving. Where questions exist, depth of penetration should be increased as this typically has very little impact on construction costs unless more difficult ground conditions are encountered.

### 3.4 RADIUS OF CURVATURE

The radius of curvature typically used in designing HDD paths is 1,200 times the nominal diameter of the pipe to be installed (DCCA 1995, para. D.2; Hair and Hair 1988, p. 17). This connection between pipe diameter and radius of curvature is derived from established practice for steel pipe rather than from theoretical analysis. Reduction of the design radius from this standard is possible, particularly for high-density polyethylene pipe. The cold-bending radius for HDPE pipe in HDD and other pull-in applications is usually limited to 40 to 50 times the diameter. However, reduction in radius will increase bending stress and pulling load on steel pipe. These factors are discussed in more detail in Section 4.

### 3.5 DIRECTIONAL ACCURACY AND TOLERANCES

It is important that the design engineer be aware that the actual drilled path cannot be constructed exactly on the specified drilled path. The specified drilled path serves as a reference line against which downhole survey data can be compared to assess conformance with design. Allowable deviations from the specified drilled path must be provided taking into account constraints at a particular location.

This is particularly critical where HDD is being used to install a gravity sewer. The required line and grade tolerances may not be achievable or may be achievable only after multiple pilot holes have been attempted.

Generally, a greater specified tolerance will afford a more economical HDD construction by the drilling contractor by minimizing the required frequency of pilot hole re-drilling. Differences between the specified drilled path and the actual drilled path are caused by the downhole tooling and the driller's ability to control changes in direction, plus by the inaccuracies in downhole surveying methods and variations in subsurface conditions. A reasonable target at the pilot hole exit location is 10 ft left or right and -10 to +30 ft in length (DCCA 1995, para. E.1).

### 3.6 MULTIPLE-LINE INSTALLATIONS

Horizontal directional drilling installations will often involve multiple lines. Multiple-line installations can be achieved by placing individual pipes in individual holes along roughly parallel paths or by placing a bundle of lines in one drilled hole.

Where multiple lines are to be placed in individual holes, decisions must be made with respect to vertical and horizontal spacing. A site-specific evaluation of directional accuracy is necessary and should take into account the drilled length, subsurface conditions, possible downhole survey system interference, and the practicality of using a surface monitoring system. Tolerances must be set so that the pilot holes are not drilled so close to one another that damage could result during reaming and pullback operations. Downhole surveying and as-built documentation are discussed in Section 6.

Multiple lines may be placed in a single drilled hole by joining them to a common pulling head and installing them as a bundle (PRC 1995, p. 36). It is not necessary that the lines be tied together in a fixed bundle although this can yield benefits when installing HDPE pipe since the tensile capacity of the bundle will be greater than the tensile capacity of an individual line. Where separation of steel lines is required for cathodic protection reasons, rubber spacers have been used. However, spacers should be avoided if possible since they can increase drag. Pipe bundles may roll during installation. This should be taken into account in planning for tie-ins to approach piping at each end of the drilled segment.

### 3.7 CASINGS

Casings are not typically used in HDD installations, because they require an additional step in the construction process and thus increase cost. Where casings are employed, it is usually to provide strength to resist installation loads as in the case of HDPE pipe within a steel casing. Although HDPE may have been selected because of its resistance to corrosion during operation, it may not have the tensile capacity to resist installation loads over a long drilled segment. The steel casing provides the structural strength needed for HDD installation. From an HDD design standpoint, no differentiation is made between a casing and carrier or product pipe. HDD operations are essentially the same.

*This page intentionally left blank*

## **Section 4**

# **PIPE DESIGN**

### **4.1 INTRODUCTION**

Load and stress analysis for an HDD pipeline installation is different from similar analyses of conventionally buried pipelines because of the relatively high tension loads, bending, and external fluid pressures acting on the pipeline during the installation process. In some cases these loads may be higher than the design service loads (PRC 1995, p. 37). Pipe properties such as strength and wall thickness must be selected such that the pipeline can be both installed and operated within customary risks of failure. Analysis of the loads and stresses that govern pipe specification can most easily be accomplished by breaking the problem into two distinct events: installation and operation.

### **4.2 INSTALLATION LOADS**

During HDD installation, a pipeline segment is subjected to tension, bending, and external pressure as it is pulled through a prereamed hole. The stresses and failure potential of the pipe are a result of the interaction of these loads (PRC 1995, p. 37). In order to determine whether a given pipe specification is adequate, HDD installation loads must first be estimated so that the stresses resulting from these loads can be calculated. The purpose of this section is to describe the loads that act on a pipeline during installation by HDD and to present methods that can be used to estimate these loads.

#### **4.2.1 Tension**

Tension on the pull section results from three primary sources: frictional drag between the pipe and the wall of the hole, fluidic drag from viscous drilling fluid surrounding the pipe, and the effective (submerged) weight of the pipe as it is pulled through the hole. In addition to these forces that act

within the drilled hole, frictional drag from the portion of the pull section remaining on the surface (typically supported on rollers) also contributes to the tensile load on the pipe.

Additional loads that the horizontal drilling rig must overcome during pullback result from the length of the drill string in the hole and the reaming assembly that precedes the pull section. These loads do not act on the pull section and therefore have no impact on pipe stresses. Nonetheless, if a direct correlation with the overall rig force is desired, loads resulting from the reaming assembly and drill string must be estimated and added to the tensile force acting on the pull section.

Calculation of the tensile load required to install a pipeline by HDD is relatively complicated because the geometry of the drilled path must be considered along with properties of the pipe being installed, subsurface materials, and drilling fluid. Assumptions and simplifications are typically required. A theoretical pulling load may be calculated by hand or with the aid of one of several personal computer-based calculation routines on the market.

Regardless of the method used to calculate an HDD pulling load, the design engineer should be aware that pulling loads are affected by numerous variables, many of which are dependent upon site-specific conditions and individual contractor practices. These include prereaming diameter, hole stability, removal of cuttings, soil and rock properties, drilling fluid properties, and the effectiveness of buoyancy control measures. Such variables cannot easily be accounted for in a theoretical calculation method designed for use over a broad range of applications. For this reason, theoretical calculations are of limited benefit unless combined with engineering judgment derived from experience in HDD construction.

The first step in calculating a pulling load is to analyze the drilled path. This analysis can be based on the designed drilled path, a "worst-case" drilled path, or "as-built" pilot hole data, if available. Bearing in mind that most pilot holes are drilled longer, deeper, and to tighter radii than designed, a conservative approach in the absence of as-built pilot hole data is to evaluate a worst-case drilled path, which takes into account potential deviations from the design. This worst-case path should be determined based on allowable tolerances for pilot hole length, elevation, and curve radius as defined in the contract documents. The design engineer should be aware that significant deviations in these parameters are typical and generally due to conditions beyond the control of the drilling contractor. For example, it would not be unusual to find deflections in a pilot hole that produced a bending radius approaching 50% of the design radius.

Existing pulling load calculation methods generally involve modeling the drilled path as a series of straight and/or curved segments as necessary to define its shape. The individual loads acting on each segment are

then resolved to determine a resultant tensile load for each segment. The estimated force required to install the entire pull section in the reamed hole is equal to the sum of the tensile loads acting on all of the defined segments. It should be noted that both frictional drag and fluidic drag will always increase the tensile load because of the fact that drag forces always retard pipe movement. However, the component of the tensile load resulting from the effective weight of the pipe may be positive, negative, or zero, depending on the buoyancy of the pipe and whether the pipe segment being evaluated is being pulled upward, downward, or horizontally.

**4.2.1.1 Frictional Drag.** Frictional drag between the pipe and soil is determined by multiplying the bearing force that the pull section exerts against the wall of the hole by an appropriate coefficient of friction. A reasonable value for coefficient of friction is 0.30 for a pipe pulled into a reamed hole filled with drilling fluid (PRC 1995, p. 41). However, it should be noted that this value can vary with soil conditions. A very wet, mucky soil may have a coefficient of friction of 0.1, whereas a rough and dry soil (unlikely in an HDD installation) may have a coefficient of friction of 0.8.

For straight segments the bearing force can be determined by multiplying the segment length by the effective unit weight of the pipe and the cosine of the segment's angle relative to the horizontal. For curved segments, calculation of the bearing force is more complicated since additional geometric variables must be considered along with the stiffness of the pipe.

**4.2.1.2 Fluidic Drag.** Fluidic drag between the pipe and viscous drilling fluid is determined by multiplying the external surface area of the pipe by an appropriate fluid drag coefficient. A reasonable value for fluidic drag coefficient is 0.025 lb/in.<sup>2</sup> (Puckett 2003, p. 1352). The external surface area of any segment defined in the drilled path model can easily be determined based on the segment's length and the outside diameter of the pull section.

**4.2.1.3 Effective Weight of Pipe.** The effective weight of the pipe is the unit weight of the pull section minus the unit weight of any drilling fluid displaced by the pull section. This is typically expressed in pounds per foot. The unit weight of the pull section includes not only the product pipe, but also its contents (ducts, internal water used for ballast, etc.) and external coatings if substantial enough to add significant weight (i.e., concrete coating). Calculating the weight of drilling fluid displaced by the pull section requires that the density of the drilling fluid be either known or assumed. For HDD installations, drilling fluid density will range from ~8.9 to ~11.0 lb/gal. (PRC 1994, p. 30; HDD Consortium 2001, pp. 3–25).

Where use of a high end value for fluid density is warranted for a conservative analysis, 12.0 lb/gal. represents a reasonable upper limit.

### 4.2.2 Bending

The pull section is subjected to elastic bending as it is forced to negotiate the curvature of the hole. For a pipe with welded or fused joints this induces a flexural stress in the pipe that is dependent upon the drilled radius of curvature. For steel pipe, the relatively rigid material's resistance to bending also induces a normal bearing force against the wall of the hole. These normal forces influence the tensile load on the pipe as a component of frictional drag. Stresses and forces induced by bending are not a significant concern for ductile iron pipe being installed with flexible restrained joints.

### 4.2.3 External Pressure

During HDD installation, the pull section is subjected to external pressure from the following four sources:

- Hydrostatic pressure from the weight of the drilling fluid surrounding the pipe in the drilled annulus;
- Hydrokinetic pressure required to produce drilling fluid flow from the reaming assembly through the reamed annulus to the surface;
- Hydrokinetic pressure produced by surge or plunger action involved with pulling the pipe into the reamed hole; and
- Bearing pressure of the pipe against the hole wall produced to force the pipe to conform to the drilled path.

Hydrostatic pressure is dependent upon the height of the drilling fluid column acting on the pipe and the density of the drilling fluid that surrounds the pipe. Drilling fluid density values are discussed in Section 4.2.1.3. The height of the drilling fluid column at any given location along the drilled path is typically equal to the elevation difference between that location and the point at which there is no drilling fluid in the reamed hole. Typically, but not always, drilling fluid extends to the entry or exit point, whichever is lower.

Hydrokinetic pressure required to produce drilling fluid flow can be calculated using annular flow pressure loss formulas. These results are dependent on detailed drilling fluid properties, flow rates, and hole configuration and, because of uncertainties involving these parameters, often require a substantial application of engineering judgment to determine a reasonable value. In most cases, annular flow during pullback is low velocity with low pressure losses.

Hydrokinetic pressure due to surge or plunger action and hole wall bearing pressure cannot be readily calculated and must be estimated using engineering judgment and experience.

### 4.3 OPERATING LOADS

The operating loads imposed on a pipeline installed by HDD are not significantly different from those imposed on a conventionally installed pipeline. As a result, past procedures for calculating and limiting stresses can be applied. However, unlike a cut-and-cover installation in which the pipe is bent to conform to the trench, a continually welded or fused pipeline installed by HDD will contain elastic bends. Flexural stresses imposed by elastic bending should be checked in combination with other longitudinal and hoop stresses to evaluate whether acceptable limits are exceeded. The operating loads imposed on a pipeline installed by HDD are described in the following sections.

#### 4.3.1 Internal Pressure

As with a pipeline installed by conventional methods, a pipeline installed by HDD is subjected to internal pressure from the fluid flowing through it. For design purposes, this pressure is generally taken to be the pipeline's maximum allowable operating pressure. The internal hydrostatic pressure from the depth of the HDD installation should be considered when determining the maximum internal pressure.

#### 4.3.2 Bending

Elastic bends introduced during pullback will remain in the pipe following installation and therefore must be considered when analyzing operating stresses. These bends are typically approximated as circular curves having a radius of curvature determined from as-built pilot hole data. One common method of calculating the radius of an approximate circular curve from pilot hole data (PRC 1995, p. 80) is

$$R = (L/A)688$$

where  $R$  = radius of curvature of the drilled hole in in.;  $L$  = length drilled in ft, typically between 75 and 100 ft; and  $A$  = the total change in angle over  $L$  in degrees.

The selection of a value for  $L$  is based on engineering judgment and takes into account the actual curvature of the pipe installed in the reamed hole as opposed to individual pilot hole survey deflections.



### 4.3.3 Thermal Expansion

A pipeline installed by HDD is considered to be fully restrained by the surrounding soil. Therefore, stress will be induced by a change in temperature from that existing when the line was constructed to that present during operation.

It should be noted that the fully restrained model is not necessarily true for all subsurface conditions. Obviously, a pipeline is not fully restrained during installation or it could not be pulled through the hole. Engineering judgment must be used in considering thermal stresses and strains involved with an HDD installation.

### 4.3.4 External Pressure

In order to evaluate the impact of external pressure during operation, the minimum internal operating pressure of the pipeline should be compared against the maximum external pressure resulting from groundwater and earth load at the lowest elevation of the HDD installation.

The earth load on pipelines installed by HDD is generally a "tunnel load", where the resulting soil pressure is less than the geostatic stress. In *ASTM F 1962-99* (ASTM 1999, p. 15), the following method is recommended for calculating earth loads on HDD installations:

$$P_e = \kappa \gamma H / 144$$

where  $P_e$  = external earth pressure in lb/in.<sup>2</sup>;  $\kappa$  = arching factor;  $\gamma$  = soil weight in lb/ft<sup>3</sup>; and  $H$  = depth of cover in ft. The arching factor is calculated as follows.

$$\kappa = \{1 - \exp[(-2KH/B) \tan(\delta/2)]\} / [(2KH/B) \tan(\delta/2)]$$

where  $K$  = earth pressure coefficient;  $B$  = "silo" width in ft, which is assumed to be the reamed hole diameter;  $\delta$  = angle of wall friction in degrees, which is assumed to be equal  $\phi$ ; and  $\phi$  = soil internal angle of friction.

The earth pressure coefficient is calculated as follows:

$$K = \tan^2(45 - \phi/2)$$

## 4.4 PIPE MATERIAL

Pipe to be installed by HDD should be smooth, flexible, and have sufficient strength to resist tension, bending, and external pressure installation

loads. Pipe installed using either the assembled-line or cartridge installation method (Ariaratnam and Carpenter 2003) shall have welded, fused, or, for segmented pipe, flexible restrained joints. Installation of welded or fused joint pipe sections is best accomplished by using the assembled-line method where the individual pipe sections, typically steel or high-density polyethylene pipe, are preassembled or fabricated (welded or fused) into long pull lengths prior to pullback. Flexible restrained joint pipe sections, typically available with ductile iron pipe, may be alternatively preassembled using the assembled-line method, or, when site conditions restrict preassembling of long sections or when preferred, assembled via the cartridge method. In the cartridge method individual pipe sections are assembled and pulled into the bore path one pipe length at a time.

The majority of HDD installations have been completed using welded steel pipe. This probably results from the fact that HDD grew out of the petroleum pipeline industry where the use of steel was dictated by high-pressure service. Although installation loads need to be checked by the design engineer, the strength of steel eliminates problems with installation loads in most cases. The high strength of steel also provides contractors with a margin for error during installation. Contractors have much more flexibility in applying remedial measures to free stuck pipe with steel than with HDPE.

If acceptable from the standpoint of system design, HDPE pipe can provide several constructability benefits over steel pipe on an HDD installation. Whereas steel pipe often necessitates a substantial "breakover" radius during pullback, requiring the pull section to be lifted into an arc, HDPE pipe can typically be pulled into the hole directly off of pipe rollers. If space is not available to fabricate the pull section in one continuous segment, this reduction in breakover length can reduce the number of tie-ins required. The flexibility of HDPE pipe also provides more options for laying out the pull section as it can be bent around obstacles. Radius of curvature is generally not a concern when installing HDPE pipe since HDPE can normally withstand a tighter radius than can be achieved with the steel drill pipe used to drill the pilot hole. Therefore, the steel drill pipe limits borehole curvature. Also, the use of HDPE pipe eliminates the need for field joint coating, and fabrication of HDPE is typically faster and less expensive than fabrication of steel. However, the tensile and pressure capacities of HDPE pipe are significantly less than those of steel. As a result, analysis of installation and operating stresses is critical in order to determine whether HDPE pipe is suitable for installation by HDD.

Ductile iron pipe may also be installed by HDD using a flexible restrained joint. These joints distribute thrust or pulling force around the bell and barrel and provide an allowable joint deflection with simultaneous joint restraint. As previously mentioned, they can also be assembled for "cartridge" installations where there are limited easements or rights of

way. Ductile iron pipe manufacturers have proprietary flexible restrained joints that they recommend for HDD applications. Therefore, individual manufacturers should be contacted for detailed parameters when designing an HDD segment using ductile iron pipe (HDD Consortium 2004, p. 5). Joints with bulky glands or flanges that may result in increased drag and inhibit annular drilling fluid flow should be avoided. It should be noted that the flexibility provided by ductile iron pipe joints eliminates bending stresses in the pipe.

## 4.5 STRESSES IN STEEL PIPE

This section addresses the stresses imposed on steel pipe during both the HDD installation process and subsequent operation. Methods that can be used to calculate these stresses are also presented.

### 4.5.1 Installation Stresses

As discussed in Section 4.1, a pipeline is subjected to three primary loading conditions during installation by HDD: tension, bending, and external pressure. A thorough design process requires examination of the stresses that result from each individual loading condition as well as an examination of the combined stresses that result from the interaction of these loads.

**4.5.1.1 Tensile Stress ( $f_t$ ).** The tension imposed on a circular pipe during installation by HDD is assumed to act through the centroid of the cross section and therefore is uniformly distributed over the cross section. The tensile stress is determined by dividing the tension by the cross-sectional area. The maximum allowable tensile stress imposed on a steel pull section during installation should be limited to 90% of the pipe's specified minimum yield strength (PRC 1995, p. 46).

**4.5.1.2 Bending Stress ( $f_b$ ).** Bending stress resulting from a rigid steel pipe being forced to conform to the drilled radius of curvature can be calculated using the following equation (Young 1989, pp. 94–95):

$$f_b = (ED)/(2R)$$

where  $f_b$  = longitudinal stress resulting from bending in lb/in.<sup>2</sup>;  $E$  = modulus of elasticity for steel, 29,000,000 lb/in.<sup>2</sup> (Timoshenko and Gere 1972, p. 9); and  $D$  = outside diameter of the pipe in in.

Bending stress imposed on a steel pull section during installation should be limited as follows (PRC 1995, p. 46). These limits are taken from design criteria established for tubular members in offshore structures and are applied to HDD installation because of the similarity of the loads on pipe (ANSI/API 1993, pp. 40–41):

$$\begin{aligned}
 F_b &= 0.75F_y && \text{for } D/t \leq 1,500,000/F_y \\
 F_b &= [0.84 - (1.74F_y D)/(Et)]F_y && \text{for } 1,500,000/F_y < D/t \leq 3,000,000/F_y \\
 F_b &= [0.72 - (0.58F_y D)/(Et)]F_y && \text{for } 3,000,000/F_y < D/t \leq 300,000,
 \end{aligned}$$

where  $F_b$  = maximum allowable bending stress in lb/in.<sup>2</sup>;  $F_y$  = pipe specified minimum yield strength in lb/in.<sup>2</sup>; and  $t$  = pipe wall thickness in in.

In the HDD industry, it is standard practice to design circular sag bends for steel pipelines at a radius of curvature of 1,200 times the nominal diameter of the product pipe (refer to Section 3.4). This relationship has been developed over a period of years in the HDD industry and is based on experience with constructability as opposed to pipe stress limitations. Typically, the minimum radius determined using the stress-limiting criterion presented previously would be substantially less than 1,200 times the nominal diameter. For this reason, bending stress limits rarely govern geometric drilled path design but are applied, along with other stress-limiting criteria, in determining the minimum allowable radius of curvature.

**4.5.1.3 External Hoop Stress ( $f_h$ ).** Thin-walled tubular members, such as steel pipe, will fail by buckling or collapse when under the influence of external hoop stress. A traditional formula established by Timoshenko for calculation of the wall thickness required to prevent collapse of a round steel pipe is as follows (Merritt 1968, pp. 21–37):

$$t = D/12(864P_{\text{ext}}/E)^{1/3}$$

where  $P_{\text{ext}}$  = uniform external pressure in lb/in.<sup>2</sup>.

Since pipe in an HDD pull section will not necessarily be perfectly round and will be subject to bending and dynamic loading, a conservative factor of safety should be applied in checking pipe wall thickness using the above relationship. Generally speaking, diameter-to-wall thickness ratios for steel pipe to be installed by HDD should be held at 60 or below, although higher  $D/t$  ratios are appropriate if a high level of confidence exists in collapse analysis calculations or a counterbalancing internal pressure will be applied during pullback (O'Donnell 1996).

As with bending, hoop stress resulting from external pressure can be checked using criteria established for tubular members in offshore structures (PRC 1995, pp. 46–47). Applicable formulas are presented in the following (ANSI/API 1993, pp. 41–42):

$$\begin{aligned}
 f_h &= P_{\text{ext}}D/2t \\
 F_{\text{he}} &= 0.88E(t/D)^2 && \text{for long unstiffened cylinders} \\
 F_{\text{hc}} &= F_{\text{he}} && \text{for } F_{\text{he}} \leq 0.55F_y \\
 F_{\text{hc}} &= 0.45F_y + 0.18F_{\text{he}} && \text{for } 0.55F_y < F_{\text{he}} \leq 1.6F_y \\
 F_{\text{hc}} &= 1.31F_y/[1.15 + (F_y/F_{\text{he}})] && \text{for } 1.6F_y < F_{\text{he}} \leq 6.2F_y \\
 F_{\text{hc}} &= F_y && \text{for } F_{\text{he}} > 6.2F_y
 \end{aligned}$$

where  $f_h$  = hoop stress due to external pressure in lb/in.<sup>2</sup>;  $F_{\text{he}}$  = elastic hoop buckling stress in lb/in.<sup>2</sup>; and  $F_{\text{hc}}$  = critical hoop buckling stress in lb/in.<sup>2</sup>.

Using these formulas, hoop stress due to external pressure should be limited to 67% of the critical hoop buckling stress.

**4.5.1.4 Combined Installation Stresses.** The worst-case stress condition for the pipe will typically be located where the most serious combination of tensile, bending, and external hoop stresses occur simultaneously. This is not always obvious in looking at a profile of the drilled hole because the interaction of the three loading conditions is not necessarily intuitive. To be sure that the point with the worst-case condition is isolated, it may be necessary to do a combined stress analysis for several suspect locations. In general, the highest stresses will occur at locations of tight radius bending, high tension (closer to the rig side), and high hydrostatic head (deepest point) (PRC 1995, p. 45).

Combined stress analysis may begin with a check of axial tension and bending according to the following limiting criterion (PRC 1995, p. 47). The criterion is taken from practices established for design of tubular members in offshore structures with an increase in the allowable tensile proportion to make it consistent with established practice in the HDD industry (ANSI/API 1993, p. 42):

$$f_t/0.9F_y + f_b/F_b \leq 1$$

where  $f_t$  = tensile stress in lb/in.<sup>2</sup>.

The full interaction of axial tension, bending, and external pressure stresses should be limited according to the following criteria (ANSI/API 1993, pp. 43–44; PRC 1995, p. 47):

$$A^2 + B^2 + 2\nu|A|B \leq 1$$

where  $A = [(f_t + f_b - 0.5 f_h)1.25]/F_y$ ;  $B = 1.5 f_h/F_{hc}$ ; and  $\nu =$  Poisson's ratio, 0.3 for steel (ASME/ANSI 1986, p. 28).

It should be noted that failure to satisfy the unity checks presented previously does not mean that the pipeline will necessarily fail by overstress or buckling. Rather, it indicates that the combined stress state places the design in a range where some test specimens under similar stress states have been found to be subject to failure (PRC 1995, p. 48).

## 4.5.2 Operating Stresses

The operating loads and stresses in a pipeline installed by HDD are not materially different from those experienced by pipelines installed by cut-and-cover techniques with one exception, elastic bending. A pipeline installed by HDD will contain elastic bends. It will not be bent to conform to the drilled hole as a pipeline installed by cut-and-cover is bent to conform to the ditch. Bending stresses imposed by HDD installation should be checked in combination with other longitudinal and hoop stresses experienced during operation to evaluate whether acceptable limits are exceeded. Other longitudinal and hoop stresses that should be considered will result from internal pressure, elastic bending, and thermal expansion and contraction (PRC 1995, pp. 56–57).

**4.5.2.1 Internal Hoop Stress ( $f_h$ ).** Hoop stress due to internal pressure is calculated as follows (ASME/ANSI 1986, p. 12):

$$f_h = (P_{\text{int}}D)/(2t)$$

where  $f_h =$  hoop stress due to internal pressure in  $\text{lb}/\text{in.}^2$ ; and  $P_{\text{int}} =$  uniform internal pressure in  $\text{lb}/\text{in.}^2$ .

The maximum allowable hoop stress due to internal pressure will be governed by the design standard applicable to the pipeline transportation system that contains the HDD segment being examined. For example, hoop stress is limited to 72% of the specified minimum yield strength for liquid petroleum pipelines (ASME/ANSI 1986, p. 9). For natural gas pipelines, hoop stress limitations range from 40 to 72% of the specified minimum yield strength (CFR 2001, para. 192.111).

**4.5.2.2 Bending Stress ( $f_b$ ).** Bending stresses are calculated and limited as shown in Section 4.5.1.2.

**4.5.2.3 Thermal Stress ( $f_e$ ).** Thermal stress resulting from changes in pipe temperature from the point in time at which the pipe is restrained by the surrounding soil to typical operating condition is calculated as follows

(ASME/ANSI 1986, p. 28):

$$f_e = E\alpha(T_2 - T_1)$$

where  $f_e$  = longitudinal stress from temperature change in lb/in.<sup>2</sup>;  $\alpha$  = coefficient of thermal expansion for steel in in./°F;  $T_1$  = temperature at installation, or when the pipeline becomes restrained, in °F; and  $T_2$  = operating temperature in °F.

The high thermal conductivity of steel enables the temperature of the pipe to equalize with the surrounding soil within a matter of hours after construction. Since soil temperatures at the depth of most HDD installations are relatively constant, thermal stresses are typically a concern only when the temperature of the product flowing through the pipeline differs substantially from that of the surrounding soil, such as in hot oil pipelines or immediately downstream of a natural gas pipeline compressor station.

**4.5.2.4 Combined Operating Stresses.** Hoop, thermal, and bending stresses imposed on the pipe during operation should be combined and checked to evaluate the risk of failure from combined stresses. This can be accomplished by examining the maximum shear stress at selected elements on the pipe. Maximum shear stress is calculated by the following formula (Timoshenko and Gere 1972, p. 48):

$$f_v = (f_c - f_l)/2$$

where  $f_v$  = maximum shear stress in lb/in.<sup>2</sup>;  $f_c$  = total circumferential stress in lb/in.<sup>2</sup>; and  $f_l$  = total longitudinal stress in lb/in.<sup>2</sup>.

In this analysis, all tensile stresses are positive and compressive stresses are negative. The total circumferential stress is the difference between the hoop stress due to external pressure and the hoop stress due to internal pressure. The total longitudinal stress is the sum of the bending and thermal stresses, and the longitudinal component of circumferential stress is determined as follows:

$$f_{lh} = f_c \nu$$

where  $f_{lh}$  = longitudinal component of circumferential stress in lb/in.<sup>2</sup>.

Presuming that hoop stresses will be positive for pressurized steel pipelines, the pipe element that will typically have the highest maximum shear stress is that which has the highest total longitudinal compressive stress. This element will fall the maximum distance from the neutral axis on the compression side of an elastic bend. Maximum shear stress should

be limited to 45% of the specified minimum yield strength (ASME/ANSI 1986, p. 9).

## 4.6 STRESSES IN HIGH-DENSITY POLYETHYLENE PIPE

This section presents methods that can be used to calculate installation and operational stresses in high-density polyethylene pipe along with stress-limiting criteria.

### 4.6.1 Installation Stresses

When installing HDPE pipe by HDD, installation stresses can often be reduced substantially by filling the pull section with water as it is being pulled into the reamed hole. This practice has two primary benefits. First, with a specific gravity of less than 1, HDPE pipe is extremely buoyant when submerged in drilling fluid. Filling the pull section with water decreases the buoyant force exerted by the pipe on the top of the reamed hole, thereby reducing the pulling load. Second, the pressure exerted by the water in the pipe counteracts the external hydrostatic pressure exerted by the drilling fluid in the annulus. This increases the factor of safety relative to collapse.

**4.6.1.1 Tension.** In order to determine whether a given HDPE pipe specification is sufficient to resist the tensile loads encountered during HDD installation, a pulling load analysis should first be performed to estimate the force required to pull the pipe into a prereamed hole. In order to account for potential deviations from the drilled path design, this analysis should be based on the worst-case drilled path as described in Section 4.2.1. A methodology for estimating pulling load on HDPE pipe is given in *ASTM F 1962-99* (ASTM 1999). Of primary concern with the installation of HDPE pipe by HDD is the possibility of tensile yield, resulting from high axial forces applied to the pipe as it is pulled into the reamed hole. This susceptibility is attributable to not only HDPE's relatively low tensile yield strength, but also to the fact that the safe tensile load applicable to HDPE pipe is time-dependent. An HDPE pipe subjected to excessive tensile load will continue to elongate until the load is released, potentially resulting in localized herniation in the pipe. According to *ASTM F 1804-97* (ASTM 1997, pp. 1–2), allowable HDD installation tensile stress for HDPE pipe may be determined as follows:

$$f_t = S_y S_t T_y$$

where  $f_t$  = allowable tensile stress in lb/in.<sup>2</sup>;  $S_y$  = tensile yield design factor, 0.4 is recommended in the absence of a factor from the pipe



manufacturer;  $S_t$  = time under tension design factor, based on 5% strain, 1.00 for 1 h or less, 0.95 for 1 to 12 h, and 0.91 for 12 to 24 h; and  $T_y$  = tensile yield strength at the pipe installation temperature in lb/in.<sup>2</sup>.

Time under tension for an HDD pullback will generally be under 1 h because of the fact that the tensile force applied by an HDD rig is released every 30 ft to remove drill pipe as opposed to being sustained for the entire duration of the pullback operation. However, use of 0.95 for  $S_t$  is typical to include an element of conservatism in design.

The estimated pulling force should be compared against the allowable pulling force determined by multiplying the cross-sectional area of the pipe by the allowable tensile stress. If the estimated pulling force is less than the allowable pulling force, the pipe specification is considered to be suitable. However, it should be noted that pulling loads may exceed estimated values, especially if the pipe should become stuck, forcing the HDD contractor to apply greater than anticipated force to free the pipe.

**4.6.1.2 Bending.** When installing HDPE pipe by HDD, bending stress is typically not critical. Manufacturers of HDPE pipe state that HDPE pipe can be cold-bent to a radius of 20 to 40 times the pipe diameter (although experience has shown that HDD design radii should be considerably more conservative than the pipe manufacturer's recommended radius because of the bending limits of the steel drill pipe). For a 48-in. pipe, multiplying the outside diameter by 40 equates to a radius of 160 ft. This radius is substantially smaller than the radius that can be achieved during pilot hole drilling with steel drill pipe. For example, the design radius for an HDD installation to be drilled using 5-in. drill pipe should typically not be less than 700 ft.

**4.6.1.3 External Pressure.** Another critical issue with the installation of HDPE pipe by HDD is the possibility of pipe collapse due to external pressure exerted by the drilling fluid in the annulus. According to *ASTM F 1962-99* (ASTM 1999, p. 9), the critical external collapse pressure of HDPE pipe may be determined using Levy's equation as follows:

$$P_c = [2E/(1 - \nu^2)][1/(DR - 1)]^3 S_0 S_r$$

where  $P_c$  = critical collapse pressure lb/in.<sup>2</sup>;  $E$  = apparent (time-corrected) modulus in lb/in.<sup>2</sup> for the grade of material used to manufacture the pipe, and time and temperature of interest;  $\nu$  = Poisson's ratio for HDPE, 0.45 for long-term loading, 0.35 for short-term loading;  $DR$  = dimension ratio, outside diameter divided by wall thickness;  $S_0$  = ovality compensation factor; and  $S_r$  = tensile pull reduction factor.

In the absence of specific information from the pipe manufacturer, the values that follow can be used for the time-dependent apparent modulus at 73°F (22.78°C) (ASTM 1999, p. 14).

Duration	$E$
Short-term	110,000
10 h	57,500
100 h	51,200
50 yr	28,200

The ovality compensation factor can be determined from the following table (ASTM 1999, p. 9):

% Ovality	$S_o$
0	1.0
2	0.85
4	0.70
6	0.55
8	0.43
10	0.36
12	0.35

A conservative value for the tensile pull reduction factor is 0.65. This factor is determined according to *ASTM F 1962-99* (ASTM 1999, pp. 11–12), with the maximum average axial tensile pull stress set at the safe pull tensile stress.

The critical collapse pressure should then be reduced by a factor of safety of 2 to yield the allowable external pressure during pullback. In most cases, it will be necessary to install HDPE pipe filled with water to counterbalance the external pressure and produce a net pressure that does not exceed the allowable.

When analyzing HDD pullback operations, a service life of one day is appropriate. The external pressure exerted by drilling fluid of a known (or assumed) unit weight can be calculated as discussed in Section 4.2.3.

#### 4.6.2 Postinstallation Stresses

Postinstallation loading conditions that should be analyzed for HDPE pipe include both normal operation and an extended shutdown during which the HDPE pipe is empty.

**4.6.2.1 Internal Pressure.** Manufacturers of HDPE pipe typically publish the internal pressure ratings of their products as a function of pipe dimension ratio (DR). These pressure ratings are based on the allowable hoop stress that can exist in the pipe wall continuously over a minimum service life of 50 years. The internal operating pressure of an HDPE pipeline should not exceed the internal pressure rating specified by the pipe manufacturer. Internal pressure considerations should be based on the lowest point of the installed pipe. Internal pressure rating can be determined using the following formula (AWWA):

$$P_{\text{int}} = 2 f_h / (\text{DR} - 1)$$

where  $P_{\text{int}}$  = internal pressure in lb/in.<sup>2</sup>; and  $f_h$  = hydrostatic design stress in lb/in.<sup>2</sup>.

**4.6.2.2 External Pressure.** If the maximum external pressure exceeds the minimum internal operating pressure, the pipeline will be subjected to a differential external pressure equal to the difference between these pressures. This differential pressure should be less than the critical collapse pressure calculated in accordance with Section 4.6.1.3 and with  $S_r = 1$ .

External pressure resulting from earth load will cause vertical deflection in HDPE pipe. This vertical deflection reduces the collapse strength proportional to the ovality compensation factor. Earth pressure may be calculated as described in Section 4.3.4. Vertical deflection is calculated as follows:

$$\Delta/D = (0.0125 P_e / E) / 12(\text{DR} - 1)^3$$

where  $\Delta/D$  = % ovality used to determine the ovality compensation factor.

The safe long-term deflection of polyethylene pipe should be limited to the lesser of 0.5(DR-1)% or 6%. In the case of an extended shutdown during which the HDPE pipe is empty, there will be no operating pressure or hydrostatic pressure within the pipe. In order to protect the pipe from collapse under such conditions, the maximum external pressure should be compared against the critical collapse pressure for the maximum potential duration that the pipe would be empty.

**4.6.2.3 Thermal.** Following installation, an HDPE pipe segment should be cut to length only after reaching thermal equilibrium with the surrounding soil. Good practice is to "overpull" the pipe to allow for the contraction of a HDPE pipeline after pulling. Contraction occurs as a result of thermal stabilization and relaxation from the pulling force. Soil temperatures at the

depth of most HDD installations are fairly constant; therefore thermal expansion and contraction due to variation in soil temperature are typically minimal. As stated previously, a pipeline installed by HDD is considered to be fully restrained by the surrounding soil. Therefore, a buried HDPE pipeline operating at a temperature that differs from that of the surrounding soil may develop some initial thermal stress during start-up. However, these stresses are believed to dissipate over time through stress relaxation and are not considered to be critical.

## 4.7 STEEL PIPE CORROSION COATING

Steel pipe is subject to corrosion and is therefore generally installed with an external corrosion coating. External coatings used in HDD installations should be well bonded to the pipe to resist soil stresses and have a smooth hard surface to reduce friction and maintain the corrosion barrier (DCCA 1995).

There are numerous external coating products currently on the market, some designed specifically for HDD installations. Mill-applied thin film fusion-bonded epoxy is commonly recommended in a minimum thickness of 20 mils (DCCA 1995).

It should be noted that concrete weight coating is not generally required on HDD installations as the deep, undisturbed cover provided in most cases serves to restrain buoyant pipelines (PRC 1995, p. 36).

### 4.7.1 Field Joint Coating

Field joint coatings must be compatible with the mill-applied coating and maintain a continuous, smooth, and abrasion-resistant surface. Twenty-five mils of fusion-bonded epoxy field-applied in two-part powder form using an induction heater is commonly recommended. An alternate to this system is two-part liquid epoxy, also in a thickness of 25 mils. Tape coatings should never be used on field joints for an HDD segment because of friction-induced peeling and tearing, making the tape coating ineffective as a corrosion barrier (DCCA 1995).

Reinforced shrink sleeves designed specifically for HDD installations are available. These sleeves should only be used in soil conditions where they will not be subject to peeling off during pullback.

### 4.7.2 Armoring Coatings

Coating loss due to abrasion from soil and very soft rock (e.g., shale, mudstone) is not a critical problem in HDD installations unless large,

abundant inclusions of significantly harder material are likely to be encountered (e.g., cobbles and boulders). Coating loss will occur during HDD installations through hard abrasive rock (e.g., granite, quartzite, hard sandstone). In general, bedrock with high unconfined compressive strength and Mohs hardness can be expected to be abrasive and cause coating wear. Point loads from sharp rock fragments and gravel may also gouge coating. Using an armoring coating over the corrosion coating can help preserve the integrity of the corrosion coating and minimize damage that can potentially occur as a result of HDD installation. The length and type of rock to be penetrated should be taken into consideration when specifying the armoring coating (Hair 2002). Generally speaking, an armoring coating of 60 mils provides adequate protection for most subsurface conditions.

## Section 5

# CONSTRUCTION IMPACT

### 5.1 INTRODUCTION

Horizontal directional drilling offers much less impact on the environment and surrounding infrastructure than other methods. Because construction is limited to either side of the obstacle, there is minimal impact on traffic (road or waterway) and other buried utilities and structures. Regulators usually designate HDD because it is the least environmentally damaging alternative.

### 5.2 WORKSPACE

The HDD process has two major construction areas: the entry side and the exit side. Heavy equipment is required on each side of the crossing. A typical large HDD rig spread mobilization involves 7 to 15 tractor-trailer loads. Where possible, access should be provided the shortest distance from improved roads to minimize costs associated with additional right-of-way improvements that would otherwise be required to provide HDD access.

The entry side (sometimes referred to as the rig side) is where the HDD rig equipment is staged and assembled. This area generally has better access and more stable ground. Horizontal directional drilling rigs come in various sizes and capacities, depending on the size of the installation. Large HDD spreads include a rig unit, power unit, generators, drilling fluid mixing/recycling equipment, drill pipe, and downhole tools. The equipment is modular, so it may be set in a variety of configurations. A large HDD spread requires a minimum area of 100 ft wide by 150 ft long with no overhead obstructions. This area should be cleared, graded level, and hard standing. A typical rig side layout is shown in Figure 5-1.

The exit side (sometimes referred to as the pipe side) is where the pipeline is fabricated. Ideally, there is space in-line with the drill alignment of sufficient length to fabricate the pipeline into one string. Delays

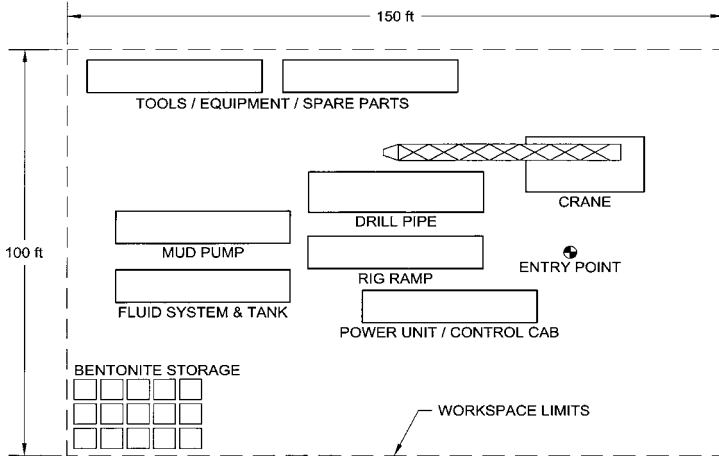

FIGURE 5-1. A Typical Rig Side Layout.

associated with connecting strings together during pullback increase risk for the HDD installation. The width of the workspace should be 50 ft, or normal for pipeline construction. If possible, additional temporary workspace should be obtained in the immediate vicinity of the exit location similar to the entry side workspace to facilitate operation of additional HDD equipment if necessary, especially on larger, longer, or more difficult HDD crossings. A typical pipe side layout is shown in Figure 5-2.

### 5.3 DRILLING FLUID

The drilling fluid is designed for the following:

- Hydraulic cutting of soft soils by use of high-velocity jets in the drill bit;
- Transmission of rotary power to the downhole mud motor;
- Lubrication, cooling, and cleaning the cutters;
- Transportation of cuttings and spoil by suspension in the fluid as it flows to the surface;
- Stabilization of the hole against collapse and minimization of fluid loss to surrounding formations;
- Reduction of friction between the drill pipe and pipeline to the wall of the drilled hole; and
- Modification of the soil by reducing the shear strength of the soil along the drill path.

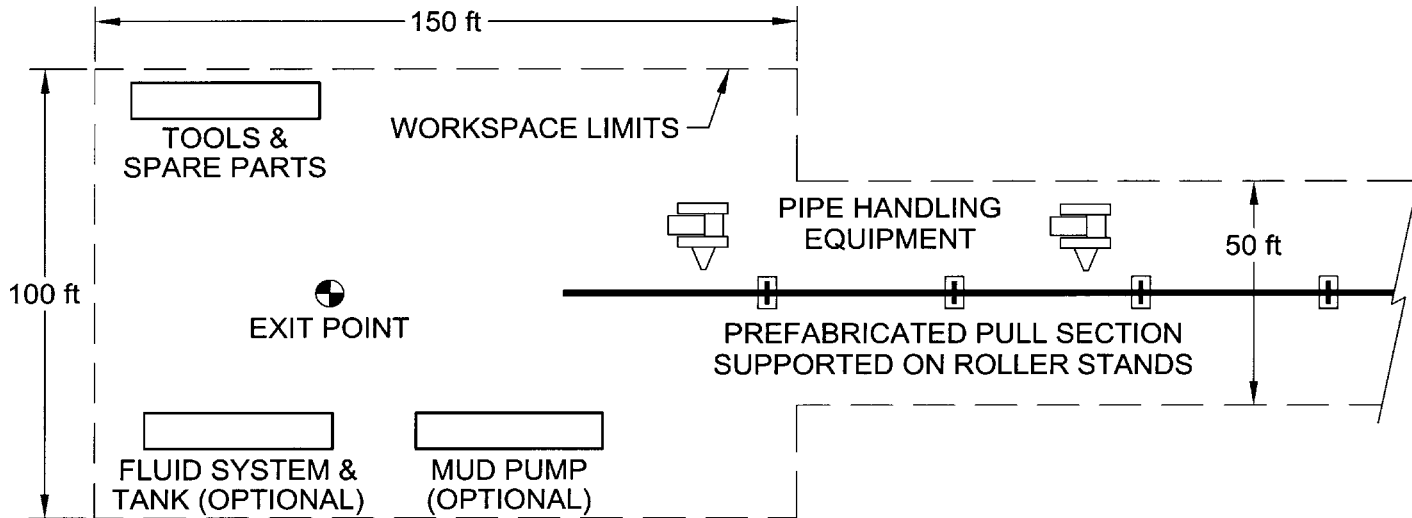

FIGURE 5-2. A Typical Pipe Side Layout.



### 5.3.1 Consumption and Characteristics

The drilling fluid is usually a mixture of fresh water, bentonite (sodium montmorillonite), and benign polymers. Bentonite is natural clay that is very hydrophilic, causing the clay particles to swell when mixed with water. This swelling increases the fluid viscosity and helps create an impervious coating on the wall of the drilled hole. Bentonite and several of its additives are nonhazardous as defined by the U.S. EPA. Material safety data sheets (MSDS) are readily available.

Horizontal directional drilling operations typically utilize significant quantities of fresh water. Consumption rates can range between 300 and 800 gal./min, depending on the phase of HDD operations (e.g., less during pilot hole, more during reaming and installation). The fresh water is mixed with drilling fluid additives to obtain specific engineered characteristics for drilling performance.

### 5.3.2 Containment and Recycling

The drilling fluid is pumped from the drilling rig through the drill pipe to the cutters. Here it is released and circulates back to the surface in the annulus between the drill pipe and the drilled hole. At the surface, it is collected in "return pits." These pits typically have a volume of at least 500 ft<sup>3</sup>.

To make the drilling fluid suitable for reuse, the cuttings and spoil must be removed. The drilling fluid returns are introduced to a solids control system. This system mechanically separates the fluid from the suspended solids. However, solids control systems are not totally efficient and the spoil discharged ranges from semi-dry particulate to thick sludge.

Recirculation of drilling fluid is complicated in an HDD installation because the drilling fluid actually returns to the surface on either side of the obstacle. In many cases, two separate solids control systems are incorporated, or the drilling fluid is transported to the opposite work area by truck, barge, temporary pipe, etc. Drilling fluid flow on an HDD installation is illustrated schematically in Figure 5-3.

### 5.3.3 Inadvertent Drilling Fluid Returns

The drilling fluid follows a path of least resistance and may not return to the containment pits but discharge to other areas along the HDD alignment. The following can cause inadvertent returns (commonly referred to as "frac outs"):

- Highly permeable soils such as gravel;
- Soils with very low permeability but are jointed (slicken-sided clays or rock fractures);

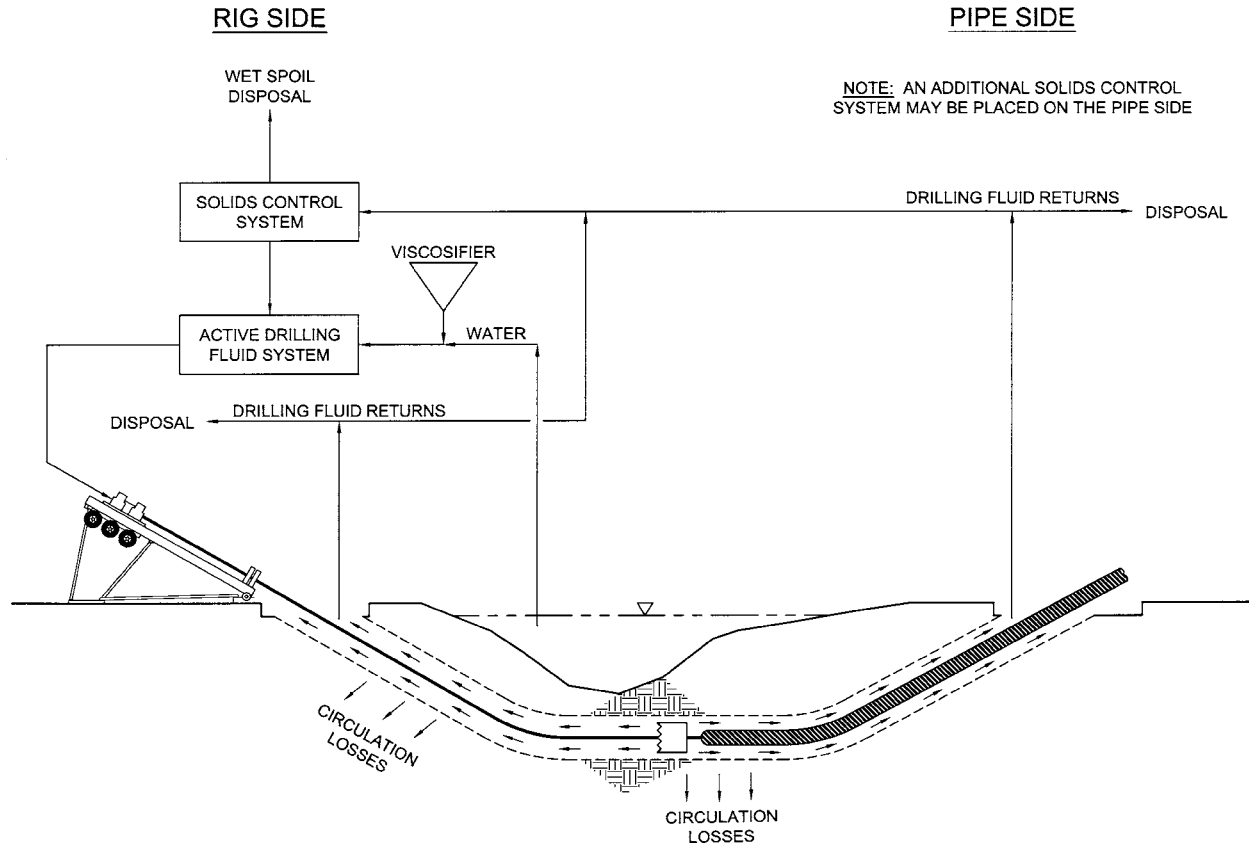

FIGURE 5-3. Drilling Fluid Flow on an HDD Installation.

- Considerable elevation differences from either the entry or exit point and ground elevations along the HDD alignment;
- Disturbed soils such as fill or soil containing piles;
- Areas along the HDD alignment where depth of cover is less than 40 ft; and
- Locations along the HDD alignment where significant variations in density and/or composition of ground conditions are encountered (e.g., overburden/bedrock contact and other types of mixed-interface transition zones).

It is important to note that, although drilling fluid and pumping parameters can be adjusted to minimize inadvertent returns, their possibility cannot be eliminated. Research projects have been conducted in an attempt to identify the mechanisms that cause inadvertent returns and to develop analytical methods for use in predicting their occurrence. Efforts have centered on predicting hydrofracturing. These programs have met with limited success in providing a reliable prediction method (USCE Waterways Experiment Station and O'Donnell Associates 1998, p. 6 and Appendices A and B). Engineering judgment and experience must be applied in utilizing the hydrofracturing model to predict the occurrence, or nonoccurrence, of inadvertent returns.

The impact of inadvertent returns is site-specific. Although a small issue in an undeveloped location, inadvertent returns may present significant problems in a congested urban environment. The impact on waterways and wetlands is likened to the environmental effects of sedimentation, siltation, and turbidity from suspended solids.

Proper contingency planning is critical for an effective response to inadvertent returns. It is important not to delay or impact the HDD operations, particularly during prereaming or pullback. Planning should include the following:

- Identify methods of rapid detection (access to the drill alignment and associated areas);
- Have suitable containment materials at the HDD site (silt curtain, hay bales, sand bags, excavation tools, plywood sheeting, etc.);
- Identify the length of time before clean-up begins (if in a traveled street then it is most likely immediate; however, it may be more suitable in other areas to allow the bentonite gel to set and dry);
- List regulatory agencies that should be notified in the case of an inadvertent return event;
- Establish ingress/egress routes and methods into environmentally sensitive areas to minimize disturbance from equipment and personnel; and

- Determine short- and long-term monitoring requirements, if any, for areas of inadvertent fluid release that are not accessible and where mitigative measures are impractical or not feasible (e.g., flowing waterways, inaccessible wetlands).

#### **5.3.4 Drilling Fluid and Cuttings Disposal**

Land farming is the least costly option for disposal of drilling fluid after an HDD project. Excess materials are spread evenly over an open area and mixed with native soil. The site can be either along the construction right-of-way or other areas nearby. In areas not delineated as wetlands, this is environmentally acceptable, and permissions for this method should be obtained before construction begins. Alternatively, the materials may be disposed at a nearby landfill. However, requiring the contractor to landfill this material may unnecessarily increase the cost of an HDD crossing, especially if local regulatory agencies allow less stringent disposal methods. Landfills typically require drying of the drilled spoil and operate limited hours, which, combined with ever-increasing tipping fees, may have a significantly negative cost impact.

Proper documentation on the volume of material removed from the drill site, specific agreements with the property owner, any landfill licenses, and testing of the drilling fluid (refer to Section 2.3.3) should be kept.

*This page intentionally left blank*

## **Section 6**

# **AS-BUILT DOCUMENTATION**

### **6.1 INTRODUCTION**

This section identifies HDD pilot hole as-built documentation requirements. The accuracy of the pilot hole as-built documentation and the preservation of this documentation are becoming more critical as utility corridors become more congested.

### **6.2 CONSTRUCTION STAKING**

Two locations, the designed entry and exit points, should be staked prior to commencing HDD operations. The elevations of the staked locations, as well as the distance between them, should be checked against the values on which the design is based. If placement of the survey stakes precedes site grading, entry and exit point elevations should be resurveyed and noted accordingly. As-built accuracy is directly dependent on the accuracy of the relative location, both horizontally and vertically, of these two points. The desired mainline tie-in stationing and vertical depth requirements at the tie-in location should be carefully considered to establish appropriate set-back distances for the HDD entry and exit points.

### **6.3 DOCUMENTATION OF ACTUAL DRILLED PATH ENDPOINTS**

The location of the entry point and exit point stakes should be preserved until measurements identifying the actual locations where the drill bit penetrates grade relative to these survey stakes are recorded. Documentation of the actual entry and exit points is critical in producing an accurate as-built drawing. The downhole survey is based on the entry point location, and the actual exit point location provides a benchmark for measuring downhole survey error.

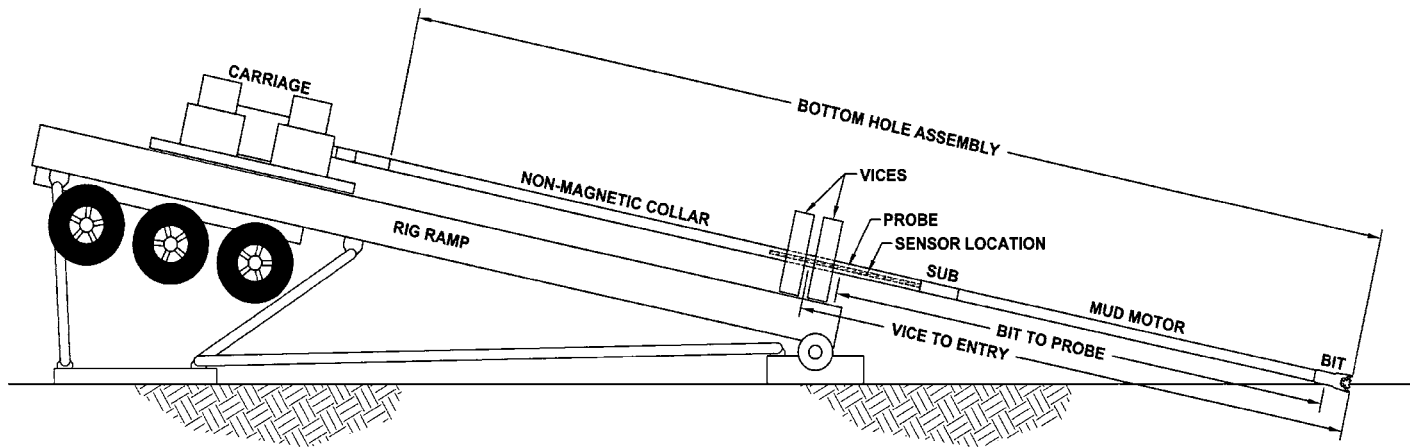

FIGURE 6-1. Required Measurements for Pilot Hole Drilling.

## 6.4 MEASUREMENTS REQUIRED PRIOR TO COMMENCING DRILLING OPERATIONS

Measurements required to survey the pilot hole during drilling should be recorded. These measurements, which are illustrated in Figure 6-1, include the bottom hole assembly length, the distance from the drill bit to the downhole probe, the distance from the staked entry point to the rig's vices, the recorded magnetic line azimuth, and steering tool information (manufacturer, supplier, serial number, recent shop calibrations, etc.). Additionally, each drill stem is measured and numbered in successive order. These measurements will be used in pilot hole survey calculations.

## 6.5 PILOT HOLE AS-BUILT CALCULATIONS

The path of the pilot hole should be recorded during drilling by taking periodic inclination and azimuth readings of the downhole probe at intervals not to exceed 35 ft. The location of the downhole probe should be calculated using downhole survey methods discussed in detail in *API Bulletin D20* (API 1985, pp. 14–16). The two methods used most commonly in the HDD industry from this bulletin are presented here for use in producing as-built drawings. These are the average angle method and the tangential method. The equations for these two methods are used to calculate the horizontal and vertical distances from the entry point as well as the distance from the reference line. Symbols used in the equations are illustrated in Figure 6-2 and defined as follows:

CL = course length;

$I_1$  = inclination angle of the previous survey point;

$I_2$  = inclination angle of the current survey point;

$A_1$  = deflection angle from the heading of the previous survey point;

$A_2$  = deflection angle from the heading of the current survey point;

HD = horizontal distance between the previous and current survey points;

RT = differential distance from the reference line between the previous and current survey points (also called "RIGHT" to indicate the distance right (positive values) or left (negative values) of the original reference line); and

VT = vertical distance between the previous and current survey points.

### 6.5.1 Average Angle Method

This method uses the average of the previous and current azimuth/inclination angles to project the measured distance along a path tangent to



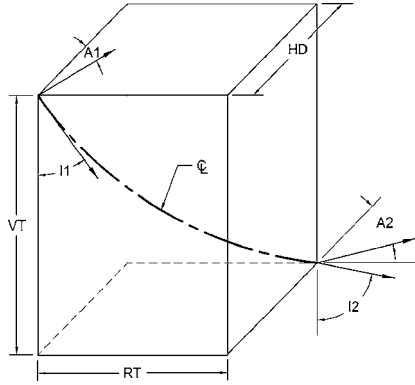

FIGURE 6-2. Calculations Used in Pilot Hole Drilling.

this average angle. The equations are as follows:

$$\begin{aligned}
 HD &= CL \cos[(A_1 + A_2)/2] \sin[(I_1 + I_2)/2] \\
 RT &= CL \sin[(A_1 + A_2)/2] \sin[(I_1 + I_2)/2] \\
 VT &= CL \cos[(I_1 + I_2)/2].
 \end{aligned}$$

**6.5.2 Tangential Method**

This method assumes that the measured distance is tangent to the current inclination/azimuth projections. The equations are as follows:

$$\begin{aligned}
 HD &= CL \sin(I_2) \cos(A_2) \\
 RT &= CL \sin(I_2) \sin(A_2) \\
 VT &= CL \cos(I_2).
 \end{aligned}$$

Either of these two methods may be used in producing the as-built drawing. To produce the as-built, the values from these equations must be summed over the drilled length.

**6.6 SURFACE MONITORING SYSTEM**

Magnetic steering tools are often used in conjunction with a surface monitoring system to correct and/or verify the initial magnetic line azimuth during drilling (this system also produces depth information but has vertical limitations). Magnetic interference will affect the accuracy of the magnetic steering tool measurements and is usually caused to varying degrees by the presence of man-made steel structures or magnetic field-producing

electric lines (surface and subsurface), and/or to a lesser degree by naturally occurring iron- or magnetic mineral-bearing ground, and magnetized drilling tools. A typical surface monitoring system is shown schematically in Figure 6-3. The system uses a surface coil of known location to induce a magnetic field. The probe senses its location relative to this induced magnetic field and communicates this information to the surface (PRC 1995, p. 4).

Surface monitoring data will generally be more accurate than the values calculated using azimuth readings in the presence of magnetic interference that adversely impacts the magnetic steering tool measurements. Where the coil cannot be set directly on the obstacle being crossed, as with a major river, calculated values based on magnetic steering tool measurements must be used. However, surface monitoring data from coils on each bank can be used to correct and/or verify the magnetic line azimuth. This aids in providing more accurate calculated alignment values, thus, improving the accuracy of the as-built drawing.

## 6.7 PILOT HOLE AS-BUILT ERROR DISTRIBUTION

All of the downhole survey instruments used to track the pilot hole contain error. Comparing the actual exit point location with the anticipated exit point location indicates this error. If the topographical survey is accurate and the downhole survey calculations are correct, then the observed difference in the two points results from inaccuracies in the downhole tool itself. This error should be distributed over the drilled path to yield an “as-built” profile.

## 6.8 PILOT HOLE AS-BUILT DRAWING

The pilot hole as-built drawing should include numbered nodes at each survey point in both the plan view and profile view referenced to a table of coordinates identifying the station, elevation, and distance right for each node. Surface monitoring data should be included if applicable. Survey error should be accounted for by establishing a plus or minus allowance in both alignment and elevation for the determined coordinate accuracy.

The pilot hole as-built survey drawing identifies the location of the drilled pilot hole within determined survey accuracy. During prereaming operations, the pilot hole tends to “egg shape” because of the weight of the bottom hole assembly, especially the softer the ground and the greater number of reaming passes that are completed. Therefore, the installed pull section may fall outside the pilot hole survey accuracy identified on the

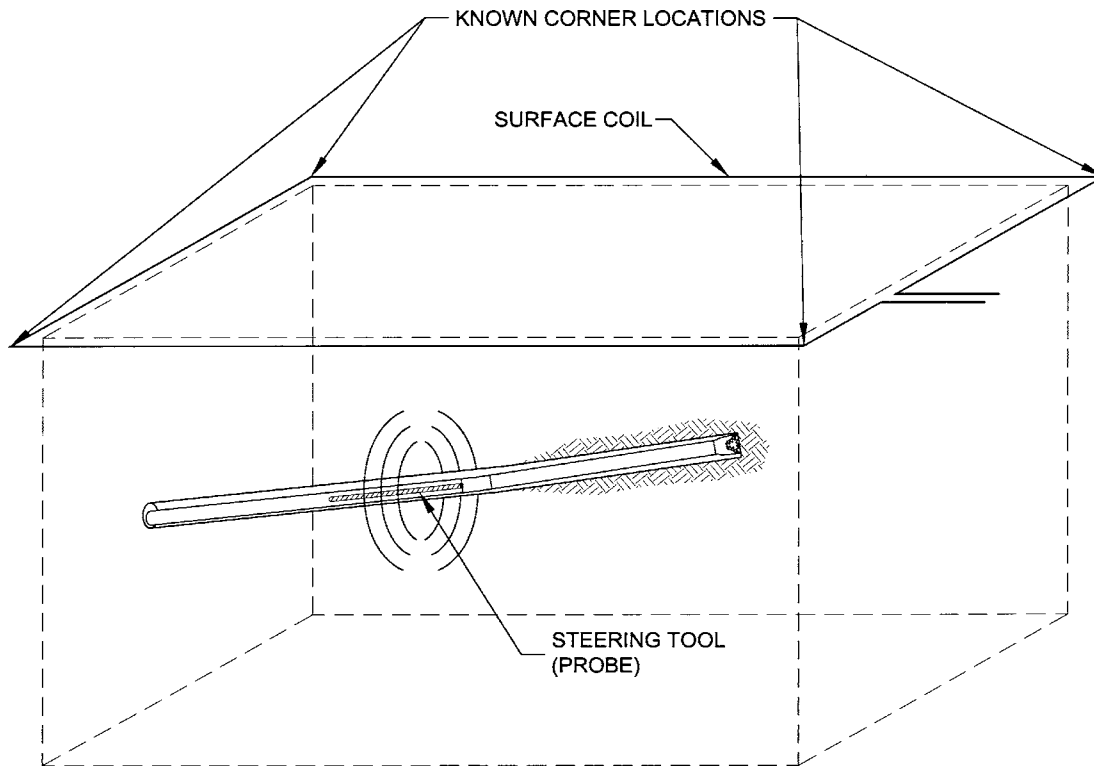

FIGURE 6-3. A Schematic Diagram of a Typical Surface Monitoring System.

drawing. If a more accurate determination of the location of the HDD segment is required, a postinstallation survey must be performed.

## **6.9 POSTINSTALLATION SURVEY**

The preferred postinstallation survey method is the gyroscopic survey system. The survey includes two runs pulling a centralized gyroscope through the installed pull section, one in each direction, for increased confidence in the installed pull section position. The gyroscopic survey measures changes in gyro sensor alignment, and integrates these changes over time, providing a continuous survey of the installed pull section both laterally and vertically with a high degree of accuracy. A gyroscopic survey may add significant cost to an HDD crossing. Therefore, the necessity and benefit should be considered accordingly.

*This page intentionally left blank*

## GLOSSARY

### A

- annulus:** The space that surrounds either the drill pipe or the product pipe and is enclosed by the borehole wall.
- API:** American Petroleum Institute, located in Dallas, Tex.
- ASTM:** American Society for Testing and Materials, located in Philadelphia, Pa.
- azimuth:** Horizontal direction expressed as an angle measured clockwise from any meridian. In HDD, azimuths are typically measured from magnetic north.

### B

- back reamer:** See *reamer*.
- barrel reamer:** An enclosed cylindrical soft soil reaming tool with cutting teeth and fluid nozzles arrayed on the end faces. Barrel reamers may be designed with specific buoyancies to aid in hole enlargement.
- bathymetric:** Relating to measurement of depth below water.
- bent sub:** A short threaded piece of pipe with an axial offset or angle used in a drill string to produce leading edge asymmetry.
- bentonite:** A colloidal clay, composed primarily of montmorillonite, which swells when wet. Because of its gel-forming properties, bentonite is a major component of drilling fluids.
- bottom hole assembly (BHA):** The combination of bit, downhole motor, subs, survey probe, and nonmagnetic collars assembled at the leading edge of a drill string.
- boulder:** A particle of rock that will not pass through a 12-in. (300-mm) square opening.
- breakover:** The over bend required to align the prefabricated pull section with the borehole during pullback without inducing plastic deformation or unacceptable flexural stresses in the pipe.
- buoyancy control:** Modification of the pull section's unit weight in order to achieve the desired buoyancy during pullback. In HDD, the most

commonly used method of buoyancy control is to fill the pull section with water as it is installed in the borehole.

## C

- carriage:** The component of a horizontal drilling rig that travels along the frame and rotates the drill pipe. It is analogous to a top drive swivel on a vertical drilling rig.
- clay:** Soil made up of particles passing a no. 200 (75- $\mu\text{m}$ ) U.S. standard sieve that can be made to exhibit plasticity (putty-like properties) within a range of water contents. Clay exhibits considerable strength when air dry.
- cobble:** A particle of rock that will pass through a 12-in. (300-mm) square opening and be retained on a 3-in. (75-mm) U.S. standard sieve.
- conduit:** A broad term that can include pipe, casing, tunnels, ducts, or channels.
- control panel:** A panel containing gauges, hydraulic valves, and controls used to operate the horizontal drilling rig.
- cuttings:** Soil or rock removed from the borehole as it is advanced or enlarged.

## D

- density:** The mass or weight of a substance per unit volume. In HDD, drilling fluid density can be expressed in pounds per gallon (ppg), pounds per cubic foot ( $\text{lb}/\text{ft}^3$ ), or kilograms per cubic meter ( $\text{kg}/\text{m}^3$ ).
- desander:** A centrifugal device (hydrocyclone) for removing sand from drilling fluid. Desanders are hydrocyclones larger than 5 in. (125 mm) in diameter.
- desilter:** A centrifugal device (hydrocyclone) for removing very fine particles, or silt, from drilling fluid. Desilters are hydrocyclones typically 4 or 5 in. (100 or 125 mm) in diameter.
- directional drilling:** See *horizontal directional drilling*.
- downhole motor:** A device that uses hydraulic energy produced by drilling fluid flow to achieve mechanical bit rotation.
- downhole probe:** See *magnetic steering tool*.
- drill bit:** A tool that cuts soil or rock at the leading edge of a drill string, usually by mechanical means.
- drilling fluid:** A mixture of water, a viscosifier (typically bentonite), and/or polymers that is pumped to the drill bit or reamer to facilitate cutting, to transport drilled spoil, to stabilize the borehole, to cool and clean cutters, and to reduce friction between the product pipe and the wall of the hole.
- drilling mud:** See *drilling fluid*.

**drill pipe:** Tubular steel conduit fitted with special threaded ends called tool joints. The drill pipe connects the horizontal drilling rig with the bit or reamer and facilitates both pumping drilling fluid and advancing or retracting the bit or reamer.

**drill stem:** See *drill pipe*.

**drill string:** The total length of drill pipe in the borehole, including the bottom hole assembly.

**duct:** Small plastic or steel pipes that enclose wires or cables for electrical or communication usage.

## E

**entry/exit angle:** The angle relative to the horizontal plane at which the drill string enters or exits the ground surface during pilot hole drilling.

**entry point:** The point on a drilled segment where the pilot hole bit initially penetrates the ground surface. The horizontal drilling rig is positioned at the entry point.

**exit point:** The point on a drilled segment where the pilot hole bit emerges from the ground surface. The pipeline pull section is typically positioned at the exit point.

## F

**flycutter:** An open circular, cylindrical, or radial blade soft soil reaming tool with cutting teeth and fluid nozzles arrayed on the circumference and blades.

## G

**gel:** An informal term for bentonite.

**gradation curve:** A plot of the distribution of particle sizes present in a soil sample.

**gravel:** Particles of rock that will pass a 3-in. (75-mm) sieve and be retained on a no. 4 (4.75 mm) U.S. standard sieve.

**grout:** A pumpable mixture, typically composed of water, cement, fine sand, flyash, bentonite, and/or chemical components, which is commonly used to fill voids or annular spaces, strengthen incompetent soil or rock, or prevent the flow of groundwater.

## H

**hole opener:** A rock reaming tool that utilizes roller cutters to cut material harder than that which can be penetrated with a flycutter.

**horizontal directional drilling (HDD):** A trenchless excavation method accomplished in three phases. The first phase consists of drilling a small diameter pilot hole along a designed directional path. The second phase



consists of enlarging the pilot hole to a diameter suitable for installation of the pipe. The third phase consists of pulling the pipe into the enlarged hole. Horizontal directional drilling is accomplished using a specialized horizontal drilling rig with ancillary tools and equipment.

**hydrocyclone:** A conical device that directs drilling fluid flow in a spiraling manner, thereby setting up centrifugal forces that aid in separating solids from the fluid.

**hydrographic survey:** A survey of a body of water to determine the configuration of the bottom.

**hydrostatic head:** See *hydrostatic pressure*.

**hydrostatic pressure:** The force exerted by a body of fluid at rest; it increases directly with the density and the depth of the fluid and is expressed in pounds per square inch or kilopascals. The hydrostatic pressure of fresh water is 0.433 lb/in.<sup>2</sup> per foot of depth (9.792 kPa/m). In drilling, the term refers to the pressure exerted by the drilling fluid in the borehole.

## I

**inadvertent return:** Uncontrolled flow of drilling fluid to the surface at a location other than the entry or exit point.

**inclination:** The angular deviation from true vertical or horizontal. In drilling, inclination is typically expressed in degrees and is measured from vertical.

## J

**jetting:** Advancing a drilled hole using the hydraulic cutting action generated when drilling fluid is exhausted at high velocity through the leading edge of a drill string.

## L

**lost circulation:** The loss of whole drilling fluid to a formation, usually in cavernous, fissured, or coarsely permeable beds, evidenced by the complete or partial failure of the drilling fluid to return to the surface as it is being circulated in the hole.

**lost circulation material (LCM):** The collective term for substances added to drilling fluids when drilling fluids are being lost to the formations downhole.

**lost returns:** See *lost circulation*.

## M

**magnetic steering tool:** A device, commonly referred to as a probe, containing instruments that measure inclination, azimuth, and tool face. A magnetic steering tool is placed at the leading edge of the drill string and provides data that the driller uses to steer the string.

**Mohs hardness:** A relative scale of hardness based on ten commonly available minerals, which provides a measure of a mineral's resistance to scratching on a scale of 1 (softest) to 10 (hardest).

**montmorillonite:** A clay mineral often used as an additive to drilling mud. It is a hydrous aluminum silicate capable of reacting with such substances as magnesium and calcium.

## O

**one call:** A utility locator service that notifies the owners of buried utilities in a given location so that the utilities can be located prior to conducting an excavation.

**over bend:** A vertical bend in the drilled path that progresses downward or the vertical bend formed in the above-ground pull section during pullback when the pull section is elevated to achieve alignment with the borehole.

## P

**pilot hole:** A small diameter hole directionally drilled along a designed path in advance of reaming operations and pipe installation.

**plunger effect:** A sudden increase in borehole pressure brought about by the rapid movement of a larger pipe or cutting tool along a drilled or reamed hole.

**polymer:** A substance that consists of large molecules formed from smaller molecules in repeating structural units. Various types of polymers are used in commercial drilling fluid products to create a drilling fluid with specific properties.

**preream:** The act of enlarging a pilot hole by pulling or pushing cutting tools through the hole prior to commencing pipe installation.

**pullback:** The act of installing a pipeline in a horizontally drilled hole by pulling it to the horizontal drilling rig from the end of the hole opposite the rig.

**pullback force:** The tensile load applied to a drill string during the pullback process.

**pullback swivel:** The device placed between the rotating drill string and the pipeline pull section to minimize torsion transmitted to the pull section during HDD installation.

**pull section:** A prefabricated pipeline segment typically staged near the HDD exit point prior to being installed in the drilled hole.

## R

**reamer:** A cutting tool pushed or pulled through the borehole in order to enlarge the hole to a diameter sufficient for installation of the product pipe.

**rock:** Any indurated material that requires drilling, wedging, blasting, or other methods of brute force for excavation.

**rock quality designation (RQD):** A modified core recovery value that expresses, as a percentage, the total length of all sound rock core pieces over 4 in. (100 mm) in length divided by the total length of the rock core run. RQD provides an indication of the fractured nature of rock.

## S

**sag bend:** A vertical bend in the drilled path that progresses upward.

**sand:** Particles of rock that will pass through a no. 4 (4.75-mm) U.S. standard sieve and be retained on a no. 200 (75- $\mu$ m) U.S. standard sieve.

**shale shaker:** A device that utilizes vibrating screens to remove larger solid particles from circulating drilling fluid. The fluid passes through the screen openings while solids are retained and moved off of the shaker by the vibrating motion.

**side bend:** A horizontal bend in the drilled path.

**silt:** Soil passing through a no. 200 (75- $\mu$ m) U.S. standard sieve that is nonplastic or very slightly plastic and that exhibits little or no strength when air dry.

**soil:** Any unconsolidated material composed of discrete solid particles with gases or liquids between.

**spoil:** Excavated soil or rock.

**standard classification of soils:** Classification of soils according to a widely used classification system, typically the Unified Soil Classification System as described in ASTM Standard D 2487.

**standard penetration test (SPT):** An indication of the density or consistency of soils determined by counting the number of blows required to drive a 2-in. (50-mm) O.D. split spoon sampler 12 in. (300 mm) using a 140-lb. (63.5 kg) hammer falling 30 in. (750 mm). The sampler is driven in three 6-in. (150-mm) increments. The sum of the blows required for the last two increments is referred to as the N-value, blow count, or standard penetration resistance.

**steering tool:** See *magnetic steering tool*.

**sub:** A short threaded piece of pipe used in a drill string to perform a special function.

## T

**tool face:** The direction of the asymmetry of a directional drilling string. A directional drilling string will progress in the direction of the tool face. Tool face is normally expressed as an angle measured clockwise from the top of the drill pipe in a plane perpendicular to the axis of the drill pipe.

**trip:** The act of withdrawing (tripping out) or inserting (tripping in) the drill string.

**twist off:** To break or separate the drill string downhole, typically due to mishandling or metal fatigue in the pipe.

## V

**vices:** The devices mounted on the frame of a horizontal drilling rig that grip the drill pipe and allow it to be made up (screwed together) or broken (unscrewed).

**viscosity:** A measure of the resistance of a liquid to flow. Resistance is brought about by the internal friction resulting from the combined effects of cohesion and adhesion.

## W

**wash pipe:** A drill pipe that is run, or rotated, concentrically over a smaller drill pipe so that the smaller (internal) pipe can be freely moved or rotated.

### Glossary References

API. (1965). *Bulletin D11*, 1st Ed.

*Drilling mud*, Unit II, Lesson 2, 3rd Ed., Rotary Drilling Series. (1984). Petroleum Extension Service, University of Texas at Austin, Tex.

*IADC drilling manual*, 11th Ed. (1992). International Association of Drilling Contractors, Houston.

Pipeline Research Committee. (1995). *Installation of pipelines by horizontal directional drilling, an engineering design guide*. American Gas Association, Washington, D.C.

*This page intentionally left blank*

## REFERENCES

- ANSI/API. (1993). Recommended practice for planning, designing and constructing fixed offshore platforms Working stress design, 20th Ed. *RP 2A-WSD-93*, Washington, D.C.
- API. (1985). Directional drilling survey calculation methods and terminology, 1st Ed. *Bulletin D20*, Washington, D.C.
- Ariaratnam and Carpenter. (2003). Installation of municipal underground infrastructure systems using horizontal directional drilling and ductile iron pipe.' *Proceed., UCT 2003*.
- ASCE. (1997). "Geotechnical baseline reports of underground construction: guidelines and practices." ASCE, New York.
- ASCE. (2003). *Standard guideline for the collection and depiction of existing subsurface utility data*. ASCE, Reston, Va.
- ASME/ANSI. (1986). Liquid transportation systems for hydrocarbons, liquid petroleum gas, anhydrous ammonia, and alcohols.' *ANSI B31.4*, New York.
- ASTM. (1997). Standard practice for determining allowable tensile load for polyethylene (PE) gas pipe during pull-in installation.' *F 1804-97*, West Conshohocken, Pa.
- ASTM. (1999). Standard guide for use of maxi-horizontal directional drilling for placement of polyethylene pipe or conduit under obstacles, including river crossings.' *F 1962-99*, West Conshohocken, Pa.
- ASTM. (1999). Standard test method for penetration test and split-barrel sampling of soils." *D 1586-99*, West Conshohocken, Pa.
- ASTM. (1999). Standard practice for rock core drilling and sampling of rock for site investigation." *D 2113-99*, West Conshohocken, Pa.
- ASTM. (2000). Standard classification of soils for engineering purposes (Unified Soil Classification System)." *D 2487-00*, West Conshohocken, Pa.
- AWWA. Polyethylene (PE) pressure pipe and fittings, 4 in. (100 mm) through 63 in. (1,575 mm), for water distribution and transmission.' *C906-99*, Denver.
- Code of Federal Regulations (CFR). (2001). Transportation of natural and other gas by pipeline: Minimum federal standards.' *Title 49, Part 192*, U.S. Government Printing Office, Washington, D.C.
- DCCA. (1995). *Guidelines for a directional crossing bid package*. Directional Crossing Contractors Association, Dallas.

- Hair, J. D. (2002). Coating requirements for pipelines installed by horizontal directional drilling.' *Pipelines 2002: Beneath Our Feet: Challenges and Solutions, Conf. Spec. Proc.* (CD ROM), Pipeline Division, ASCE, Cleveland.
- Hair, J. D., and Hair, C. W. III. (1988). Considerations in the design and installation of horizontally drilled pipeline river crossings.' *Pipeline Infrastructure, Conf. Proc.*, Pipeline Division of the American Society of Civil Engineers, Boston.
- HDD Consortium. (2001). *Horizontal directional drilling, good practices guidelines*. HDD Consortium.
- HDIPRA. (2004). *Horizontal directional drilling with ductile iron pipe*. Ductile Iron Pipe Research Association, Birmingham, Ala.
- Merritt, F. S. (1968). *Standard handbook for civil engineers*. McGraw-Hill, New York.
- ODonnell, H. W. (1978). Considerations for pipeline crossings of rivers.' *Transport. Eng. J.*, 104(4), 509–524.
- ODonnell, H. W. (1996). Investigation of pipeline failure in a horizontally directionally drilled installation.' *Pipeline Crossings 1996, Proc. Spec. Conf.*, Pipeline Division, ASCE.
- Pipeline Research Committee (PRC). (1994). *Drilling fluids in pipeline installation by horizontal directional drilling, a practical applications manual*. American Gas Association, Washington, D.C.
- Pipeline Research Committee (PRC). (1995). *Installation of pipelines by horizontal directional drilling, an engineering design guide*. American Gas Association, Washington, D.C.
- Puckett, J. S. (2003). Analysis of theoretical versus actual HDD pulling loads.' *Volume Two, New Pipeline Technologies, Security and Safety, Proc., ASCE International Conf. on Pipeline Engineering and Construction*, Technical Committee on Trenchless Installation of Pipelines (TIPS), Pipeline Division, ASCE.
- Timoshenko, S. P., and Gere, J. M. (1972). *Mechanics of materials*. Van Nostrand Reinhold, New York.
- USCE Waterways Experiment Station and ODonnell Associates, Inc. (1998). Installation of pipelines beneath levees using horizontal directional drilling.' *Tech. Rep. CPAR-GL-98-1*, U. S. Army Corps of Engineers, Washington, D.C.
- Young, W. C. (1989). *Roark's formulas for stress and strain*, 6th Ed. McGraw-Hill, New York.

## SI CONVERSION TABLE

1 foot (ft)	= 0.3048 meter (m)
1 inch (in.)	= 25.4 millimeter (mm)
1 mil	= 0.0254 millimeter (mm)
1 gallon (gal.)	= 3.7853 liter (L)
1 pound (lb)	= 0.4535 kilograms (kg)
1 pound/inch <sup>2</sup> (lb/in. <sup>2</sup> )	= 6.895 kilopascal (kPa)
1 pound/inch <sup>2</sup> (lb/in. <sup>2</sup> )	= 0.006895 megapascal
degrees Fahrenheit (°F)	= 1.8 degrees Celsius + 32 (°C + 32)



*This page intentionally left blank*

## INDEX

- accuracy, directional, 16–17
- angles: average angle method, 47–48
  - penetration, 15
- armor coating, 35–36
- as-built documentation, 45–51
  - construction staking, 45
  - drilled path endpoints, 45
  - entry and exit points, 45
  - pilot hole as-built drawing, 49, 51
  - pilot hole as-built error distribution, 49
  - pilot hole calculations, 47–48
  - postinstallation survey, 51
  - surface monitoring system, 48–49
- assembled-line installation method, 25
- bending, 22, 23
  - stresses, 26–27, 29, 32
- borings: backfilling, 9
  - exploratory, 8
- bundles, 17
- cartridge installation method, 25–26
- casings, 17
- combined stresses: installation, 28–29
  - operating, 30–31
  - stress analysis, 28–29
- construction areas, 37
- construction impact, 37–43
  - construction areas, 37
  - drilling fluid, 38, 40–43
- construction staking, 45
- contours, 4
- corrosion coating: armor coating, 35–36
  - field joint, 35
- crossings: drilled path design, 13–15
  - surface survey, 4
- cuttings, 43
  - defined, 54
- directional accuracy, 16–17
- directional tolerances, 16–17
- drag, 21
- drawings: pilot hole as-built drawing, 49, 51
  - record, 6
  - subsurface features, 6
- drilled path design, 13–17
  - analysis, 20
- drilled path endpoints, 45
- drilling fluid, 38, 40–43
  - consumption, 40
  - containment, 40
  - defined, 54
  - density, 21–22
  - disposal, 43
  - inadvertent returns, 40, 42–43, 56
  - recycling, 40
- entry and exit points, 45
- entry angles, 15
  - defined, 55
- entry side, 37
- exit angles, 15
  - defined, 55
- exit side, 37–38
- expansion, thermal, 24
- external hoop stresses, 27–28
- field joint coating, 35–36
- fluidic drag, 21
- frictional drag, 21

- GBR: *see* geotechnical baseline report
  - GDR: *see* geotechnical data report
  - geotechnical baseline report, 9
  - geotechnical data report, 9–11
  - GPR: *see* radar, ground-penetrating
  - HDD: *see* horizontal directional drilling
  - HDPE pipe: *see* pipe, high-density polyethylene
  - high-density polyethylene pipe
    - stresses, 31–35
  - horizontal directional drilling, 55
  - horizontal directional drilling,
    - defined, 1
  - inadvertent returns, 40, 42–43
    - defined, 56
  - installation: assembled-line
    - installation method, 25
  - cartridge installation method, 25–26
  - combined stresses, 28–29
  - loads, 19–23
  - methods, 25–26
  - multiple-line, 17
  - postinstallation stresses, 33–35
  - postinstallation survey, 51
  - stresses, 26–33
- installation stresses, 26–31
  - internal hoop stresses, 29
  - loads: installation, 19–23
    - operating, 23–24
    - pulling, 20–21
    - tensile, 20–21
    - tunnel, 24
  - multiple-line installations, 17
  - obstacles, 13–15
  - one-call locating service, 6
  - operating stresses, 29–31
  - penetration angles, 15
  - penetration depth, 15–16
  - pilot hole: as-built calculations, 47–48
    - as-built drawing, 49, 51
    - as-built error distribution, 49
    - calculations, 47–48
    - defined, 57
    - measurements, 47
  - pipe: composition, 24–26
    - ductile iron, 25–26
    - effective weight, 21–22
    - high-density polyethylene, 17, 25
    - locators, 7
    - postinstallation stresses, 33–35
    - side, 37–38
  - pipe, high-density polyethylene,
    - 31–35
    - stresses, 31–35
  - pipe, steel, 26–31
    - corrosion coating, 35–36
    - stresses, 26–31
    - welded, 25
  - pipeline segments, 1
  - postinstallation stresses, 33–35
  - postinstallation survey, 51
  - pressure: bearing, 22
    - external, 22–23, 24, 32, 34
    - hydrokinetic, 22
    - hydrostatic, 22
    - internal, 23, 34
  - radar, ground-penetrating, 7
  - radius of curvature, 16
  - record drawings, 6
  - rig side, 37
  - sampling, 9
  - separation distance, 15–16
  - soil conditions, 8–11
  - stresses: bending, 26–27, 29, 32
    - combined installation, 28–29
    - combined operating, 30–31
    - combined stress analysis, 28–29
    - external hoop, 27–28
    - high-density polyethylene pipe,
      - 31–35
    - installation, 26–31
    - internal hoop, 29
    - operating, 29–31
    - postinstallation, 33–35
    - steel pipe, 26–31
    - tensile, 26
    - tension, 31–32
    - thermal, 29–30, 34–35
  - subsurface features, 4–11
    - ground-penetrating radar, 7
    - one-call locating service, 6
    - pipe locators, 7
    - record drawings, 6

- seismic surveys, 8
- subsurface utility landmarks, 6
- utility research, 4–8
- vacuum excavation, 7
- subsurface utility landmarks, 6
  - confirmation methods, 6–8
- surface monitoring system, 48–49
- surveys: geotechnical, 8–11
  - hazardous material, 11
  - postinstallation, 51
  - seismic, 8
  - surface, 3–4
- tangential methods, 48
- tensile stresses, 26
- tension, 19–22
  - high-density polyethylene pipe, 31–32
  - sources, 19–20
  - stresses, 31–32
- thermal stresses, 29–30, 34–35
- tolerances, directional, 16–17
- utility research, 4–8
  - one-call locating service, 6
- vacuum excavation, 7