



PRESIDENCY UNIVERSITY

BENGALURU

Roll No.																			
----------	--	--	--	--	--	--	--	--	--	--	--	--	--	--	--	--	--	--	--

Mid - Term Examinations – March 2026

Date: 13-03-2026

Time: 09.30am to 11.00am

School: SOE	Program: B.Tech		
Course Code: ECE2021	Course Name: Digital Electronics		
Semester: II	Max Marks: 50	Weightage: 25%	

CO - Levels	CO1	CO2	CO3	CO4	CO5	CO6
Marks	10	14	14	-	-	12

Instructions:

- (i) Read all questions carefully and answer accordingly.
- (ii) Do not write anything on the question paper other than roll number.

Part A

Answer ALL the Questions. Each question carries 2marks.

5Q x 2M=10M

1	Simplify the Boolean expression using K-map: $F = A + A'B$	2 Marks	L3	CO2
2	Quine McCluskey and K-map are tabular and graphical method to simplify a complex Boolean expression. List any two advantages of K-map minimization technique over Quine McCluskey Method.	2 Marks	L1	CO2
3	Define combinational circuit? Give two examples.	2 Marks	L1	CO3
4	Full adder is a combinational circuit with three input A, B, C and two outputs Sum and Carry. Write expression for Sum and Carry for a full adder.	2 Marks	L2	CO3
5	Identify the input combination to get Logic "1" as output for the following circuit.	2 Marks	L4	CO6

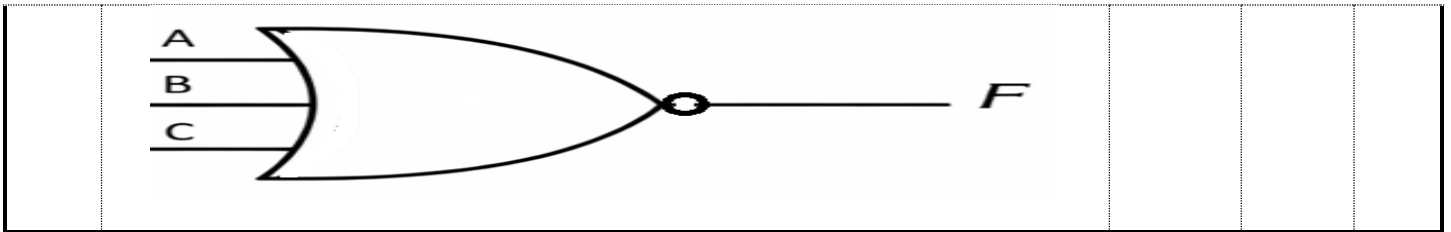

Part B

Answer the Questions.

Total Marks 40M

6.	a.	<p>Simplifying Boolean function results in an expression with minimum number of literals. Use Boolean algebra to simplify the given expression and hence realize the simplified expression using NAND gates only.</p> $F(A,B,C) = (A+B)(A'+C)+AB$	10 Marks	L3	CO1
Or					
7.	a.	<p>A Boolean expression is composed of a combination of the Boolean constants (True or False), Boolean variables, and logical connectives. Simplify the given Boolean expression using Boolean algebra and hence construct the truth table for the original and simplified Boolean expression.</p> $Y = ABC + AB'C + ABC' + A'BC$	10 Marks	L3	CO1
8.	a.	<p>Using K-map, obtain the minimized Boolean expression for the given function in SOP and POS form.</p> $F(A, B, C, D) = \sum m(1, 2, 6, 7, 8, 13, 14, 15) + d(0, 3, 5, 12)$	10 Marks	L3	CO2
Or					
9.	a.	<p>A Karnaugh Map (K-map) is a graphical method used in digital electronics to simplify Boolean algebra expressions. Simplify and implement the following POS function using NOR gates.</p> $F(A,B,C,D) = A = \pi M(2,3,6,7,8,9) + d(12,13,15)$	10 Marks	L3	CO2
10.	a.	<p>Three secret doors labelled A, B and C are the possible ways to enter a laboratory. Some thieves planned to take away the formula for certain vaccine from this lab. There is a particular combination of gates that will lead to the formula room. Police were aware of this plan. To nab the thieves, they designed a digital system that will alert them when there is entry to formula room as per the combination.</p> <ol style="list-style-type: none"> When all the GATES A, B and C are opened. When GATES A and B are opened. 	10 Marks	L3	CO3

		iii. When GATES A and C are opened. iv. When the GATES B and C are opened. Draw truth table for this situation and obtain a Boolean expression after minimization.			
--	--	--	--	--	--

Or

11.	a.	An engine has four fail-safe sensors. The engine will STOP running if any of the following conditions arise. (i) Sensor A is activated, (ii) Sensor B and C are activated at the same time, (iii) Sensor C and D are activated at the same time, (iv) Sensors B, C and D are activated at the same time. Design a system that will keep the engine running and implement the simplified logic using basic gates only.	10 Marks	L3	CO3
------------	-----------	---	-----------------	-----------	------------

12.	a.	Analyze the following truth table (with 2 inputs and 3 outputs) to find the design statement. <table border="1" style="margin-left: auto; margin-right: auto;"> <thead> <tr> <th colspan="2">Inputs</th> <th colspan="3">Outputs</th> </tr> <tr> <th>A</th> <th>B</th> <th>Output 1</th> <th>Output 2</th> <th>Output 3</th> </tr> </thead> <tbody> <tr> <td>0</td> <td>0</td> <td>0</td> <td>1</td> <td>0</td> </tr> <tr> <td>0</td> <td>1</td> <td>0</td> <td>0</td> <td>1</td> </tr> <tr> <td>1</td> <td>0</td> <td>1</td> <td>0</td> <td>0</td> </tr> <tr> <td>1</td> <td>1</td> <td>0</td> <td>1</td> <td>0</td> </tr> </tbody> </table>	Inputs		Outputs			A	B	Output 1	Output 2	Output 3	0	0	0	1	0	0	1	0	0	1	1	0	1	0	0	1	1	0	1	0	10 Marks	L4	CO6
Inputs		Outputs																																	
A	B	Output 1	Output 2	Output 3																															
0	0	0	1	0																															
0	1	0	0	1																															
1	0	1	0	0																															
1	1	0	1	0																															

Or

13.	a.	<p>In digital systems, voting logic is used to generate an output based on the number of inputs that are in the logic HIGH state.</p> <p>1-out-of-3 voting logic produces an output HIGH when at least one of the three inputs is HIGH.</p> <p>2-out-of-3 voting (Majority Voting) logic produces an output HIGH when any two or more of the three inputs are HIGH.</p> <p>3-out-of-3 voting logic produces an output HIGH only when all three inputs are HIGH.</p> <p>A logic circuit with three inputs <i>A</i>, <i>B</i>, and <i>C</i> and one output <i>F</i> is shown in the figure below.</p>	10 Marks	L3	CO6
------------	-----------	---	-----------------	-----------	------------

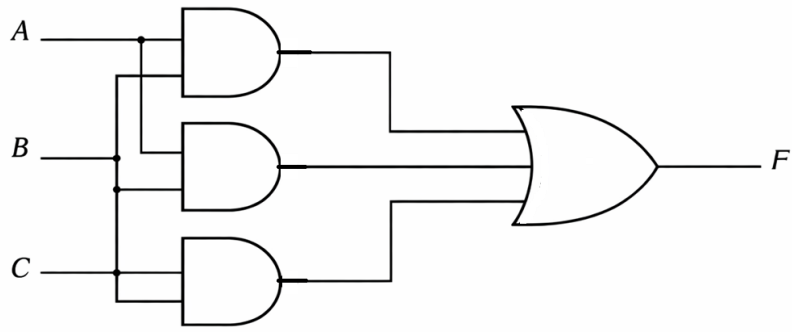

Analyse the given logic circuit to find the truth table and hence identify the type of voting logic implemented by the circuit.